

# CS CLA-VAL™

**FIRE PROTECTION PRODUCTS & APPLICATIONS**

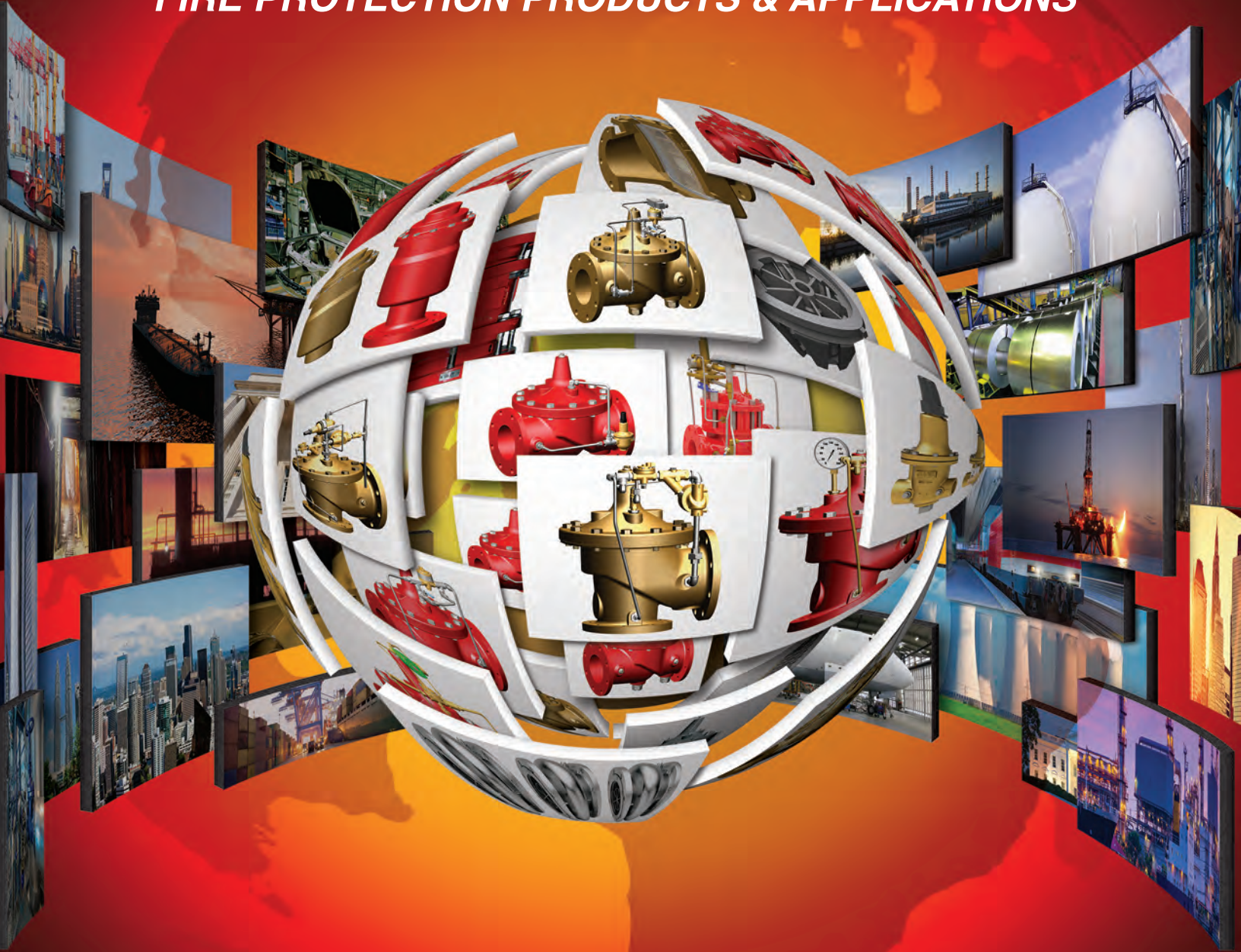

***Deluge • Pressure Relief • Pressure Reducing  
Anti-Cavitation • Pump Start Control & Relief  
Solenoid Control • Air Release Valves • Check Valves***





# TABLE OF CONTENTS

**Cla-Val Statement of Qualifications** .....4

**Main Valves**

100S/2100S Seawater Service Hytrol Valve .....8  
 100G/2100G Deluge Valve - **UL, ULC, ABS** .....12  
 100GS/2100GS Deluge Valve - **UL, ULC, ABS** .....12  
 Ti 100GS Titanium Deluge Valve Seawater Service .....14  
**Weigh the Options: Cla-Val Titanium Valves** .....16  
**Got Vibration? Anti-Cavitation Hytrol Valve for Fire Protection Applications - UL** .....17  
 100-01KO Anti-Cavitation Hytrol Valve - **UL** .....18  
 100-29S Seawater Service Reduced Port Valve .....22  
 800GS Tubular Diaphragm Deluge Valve .....26  
 100-43 Tubular Diaphragm Valve .....28  
 X43H "H" Style Strainer .....30  
 X43HL "H" Style Strainer .....32  
**Solid Performer Cla-Val X43HL "H" Style Strainer Fire Protection Application** .....34  
**Fire Protection for High Rise Building From The Street to The Sprinkler Head** .....35

**Pressure Relief Valves**

50B-4KG1 Fire Protection Pressure Relief Valve - **UL, FM, ULC, ABS** .....36  
 50B-4KG1KOL Pressure Relief Valve with Anti-Cavitation Trim **UL, FM, ULC, ABS** .....38  
 WC-01 Waste Cone .....40  
 50B-5KG Fire Protection Pump Suction Control Valve - **FM** .....42  
 50-20 Seawater Service Pressure Relief Valve .....44  
 50-49 Pressure Relief Valve - **ABS** .....46  
 55L-60 Pressure Relief Valve - **UL, FM** .....48  
 850B-4 Tubular Diaphragm Fire Relief Valve - **FM** .....50  
 850-20 Tubular Diaphragm Seawater Relief Valve .....52

**Pressure Reducing Valves**

90G-21 Fire Protection Pressure Reducing Valve - **UL, ULC** .....54  
 90-FS-PRV Factory Set Pressure Reducing Valves - **UL** .....56  
 90-PRV-175 Pressure Restricting Valves - **UL, FM** .....58  
 HV-100 Hose Valves - **UL, FM** .....60  
 90-42 Seawater Service Pressure Reducing Valve .....62  
 Cavitation Chart & Flow Charts .....64

**Deluge Valves**

**Typical Applications : Deluge Valves** .....67  
 134-05 Solenoid Control Valve - **UL, ULC Listed Main Valve** .....68  
 134-60 Seawater Service Solenoid Operated Deluge Valve - **UL, ULC Listed Main Valve** .....70  
**Optional Solenoid Controlled Deluge Valve Arrangements** .....72  
 834-05 Tubular Diaphragm Fire Deluge Valve - **FM** .....74  
 834-60 Tubular Diaphragm Seawater Fire Deluge - **FM** .....76  
**Optional Tubular Diaphragm Deluge Valve Arrangements** .....78  
 403 Series Pneumatically Operated Remote Control Valve For Freshwater and Seawater Service ...80  
 414-01 Pneumatically Operated Remote Control Valve - **UL, ULC Listed Main Valve** .....82  
**Optional Pneumatic Deluge Valve Arrangements** .....84

# TABLE OF CONTENTS



## Altitude Valve

210-01/610-01 Altitude Valve for One-Way Flow .....86

## Air Release Valves

33A High Performance Combination Air Release & Vacuum Breaker Valve .....90  
 33B High Performance Combination Air Release & Vacuum Breaker Valve .....92  
 33ATD Air Release & Vacuum Breaker Valve with Throttling Air Control Device - **UL Listed** .....94

## Check Valves

580 Silent Wafer Check Valves - FM .....96  
 581 Silent Globe Check Valves - FM .....100  
 582SWS Two Door Check Valves - FM .....104  
 582W - 582 - 582G Two Door Check Valves - **UL, FM** .....106

Flange Dimensions and End Details .....108

Warranty: Cla-Val Control Valves .....109

## Cla-Val Certifications, Approvals and Listings



Industrie Service



PED Certified Ferrous & Non-Ferrous Castings  
 Certification Number DGR-0036-QS-748-09



# Cla-Val Statement of Qualifications

## Company Overview

Since 1936, Cla-Val has been a leading manufacturer of automatic control valves, serving waterworks, fire protection, aviation fueling and industrial customers throughout the world. Our commitment to excellence and continuous improvement shows in each valve we produce and in the many new products we introduce to the marketplace each year. Cla-Val is a global company with headquarters and a 20-acre manufacturing/foundry complex in Newport Beach, California, in addition to production/office facilities in Canada, Switzerland, France, New Zealand and the United Kingdom.



Cla-Val's long history of manufacturing and industry excellence also enables us to provide the industry's most comprehensive program of hands-on, personalized technical/product training at our in-house training facilities in the US, Canada, Switzerland, the UK, France and New Zealand.

Cla-Val Automatic Control Valves are renowned for their quality and superior performance. The company is also known for consistently excellent customer service as well as innovation, specifically related to products that help to conserve water and energy.

Our company website at [www.cla-val.com](http://www.cla-val.com) offers a comprehensive overview of our extensive product line and field service capabilities as well as access to hundreds of technical documents.

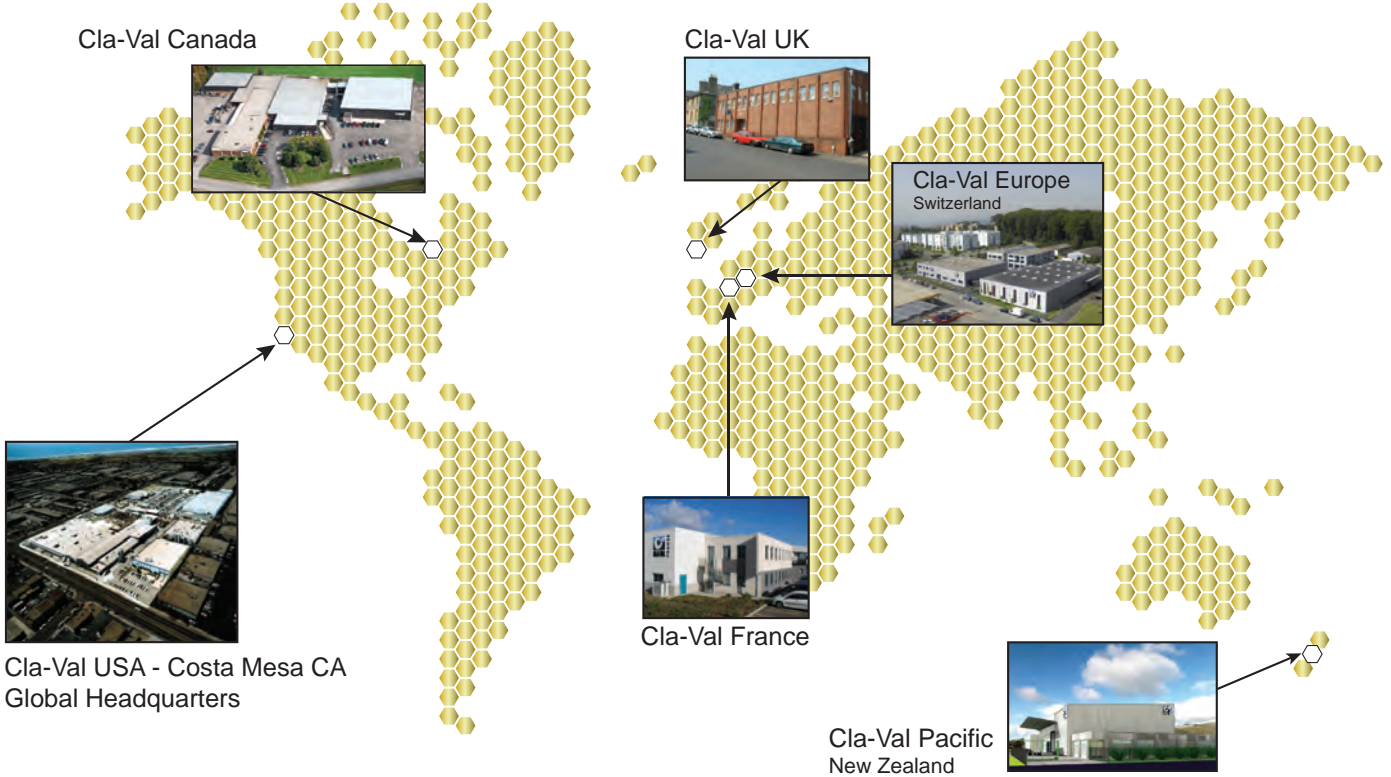

# Cla-Val Statement of Qualifications

## Onsite Foundries

**Soundcast Company – Sand casting foundry**

**Griswold Castings – Investment foundry, lost wax process**

By having two on-site foundries, Cla-Val is able to provide castings in over 50 different alloys, making our product offering one of the most extensive in the valve industry. It also allows us to quickly fulfill our customers' unique requirements. A small sample of the many materials our foundries produce include the following alloys:

- Ductile Iron
- Cast Steel
- Stainless Steel
- Monel
- Super Austenitic Stainless Steel
- Super Duplex Stainless Steel
- Titanium



## Manufacturing Facilities Overview

- State-of-the-Art Machining Cells in multiple manufacturing locations worldwide: The US, Canada, Switzerland, New Zealand and China
- Large inventory of products on the shelf and ready to ship to meet customers' immediate needs



## Worldwide References, Industry Experience and Capabilities

Because of the superior quality valves we produce, a deep level of technical expertise, and longevity in the industries we serve, Cla-Val's list of customers includes most water utility companies in North America, virtually every major city in the world, and most countries around the globe.

From fire suppression systems in high-rise buildings and industrial facilities to the rigorous demands of fire protection systems on offshore oil platforms and FPSOs, Cla-Val products provide accurate and reliable service in the most critical of applications including fire pump pressure relief valves, pump suction control valves, deluge valves, pressure regulating valves and backflow preventers. Cla-Val Breach Valves provide protection against draining of fire suppression water supplies in the event of a catastrophic breach in the piping system. Available in a wide range of special alloys, relevant Cla-Val products are MEA and ABS approved; UL and ULC listed; and have Factory Mutual approval.

---

# Cla-Val Statement of Qualifications

## Project Experience: Offshore Platforms & FPSO Fire Suppression Systems

Cla-Val has supplied superior quality valves for fire protection applications since the 1950s. You can find Cla-Val automatic control valves in fire suppression systems on offshore oil platforms, aboard Floating Production, Storage and Offloading facilities (FPSO) and in industrial and commercial facilities around the world for: Pressure Reducing; Pressure Relief; Pump Suction Control; Level Control; Deluge Service. The following is a partial list of projects where Cla-Val provided pressure control, deluge service and pump control valves for the fire protection systems in offshore oil platforms and FPSOs.

- ConocoPhillips Bohai Offshore Oil Platform and FPSO, located in China's Bohai Bay, South China Sea
- British Gas Poinsettia Offshore Oil Platform, located offshore north coast Trinidad and Tobago
- Exxon - Diana Offshore Oil Platform, located in the Gulf of Mexico, 160 miles south of Galveston, Texas
- British Petroleum Mad Dog Offshore Oil Platform, located in the Gulf of Mexico, 190 miles off the coast of New Orleans, Louisiana
- British Petroleum - Holstein Offshore Oil Platform, located in the Gulf of Mexico, 150 miles off the coast of New Orleans, Louisiana
- British Petroleum Thunder Horse Offshore Oil Platform, located in the Gulf of Mexico, 150 miles off the coast of New Orleans, Louisiana
- British Petroleum - Atlantis Offshore Oil Platform, located in the Gulf of Mexico, 150 miles off the coast of New Orleans, Louisiana
- British Petroleum - Clair Offshore Oil Platform, located in the North Sea
- Oil and Natural Gas Corporation (ONGC) Limited - Dehradun, India
- Cla-Val fire protection valves installed on several of The National Oil and Gas Company of India ONGC's offshore oil platforms, all offshore Mumbai, India



## Project Experience: High-Rise Buildings

Cla-Val's experience in manufacturing automatic control valves for commercial construction projects is unparalleled. Over the past seventy years, as the height of buildings increased and truly redefined the term high-rise, Cla-Val has been on the forefront of supplying products that meet the market's unique demands. Listed below are several high-rise building projects for which Cla-Val Automatic Control Valves are used in water distribution and fire protection applications:

- Petronas Towers - Kuala Lumpur, Malaysia
  - 1483 feet tall (452 meters), 88 floors
- Burj Khalifa - Dubai, United Arab Emirates
  - 950 meters tall, 189 floors
- Rockefeller Center - New York, New York USA
  - 268 feet tall (82 meters), 26 floors
- Seven World Trade Center - New York, New York USA
  - 520 feet tall (174 meters), 47 floors



---

# Cla-Val Statement of Qualifications

## Project Experience: High-Rise Buildings

- Trump World Tower – New York, New York USA  
861 feet tall (262 meters), 72 floors
- AOL/Time-Warner National Headquarters – NY, NY USA  
Recently completed two nearly identical towers  
Each 750 feet tall (229 meters), Each with 55 floors
- Exxon Building – New York, New York USA  
750 feet tall (229 meters), 54 floors
- Sears Tower - Chicago, Illinois USA  
1450 feet tall (442 meters), 110 floors
- Trump Tower - Chicago, Illinois USA  
1362 feet tall (415 meters), 96 floors
- John Hancock Building - Chicago, Illinois USA  
1127 feet tall (344 meters), 100 floors
- ComCast Center - Philadelphia, Pennsylvania USA  
975 feet tall (297 meters), 57 floors
- Mellon Bank Center - Philadelphia, Pennsylvania USA  
792 feet tall (241 meters), 54 floors
- Two Cal Plaza – Los Angeles, California USA  
750 feet tall (229 meters), 52 floors
- Mandarin Hotel – Singapore
  - 1200 guest rooms; Voted one the best luxury hotels in Asia, with an emphasis on comfort and safety. Scope of supply included water distribution as well as fire protection valves throughout the property
- Shanghai Grand Hyatt – Shanghai, People’s Republic of China
  - 87 floors. Scope of supply included water distribution as well as fire protection valves throughout the property



## Additional Industrial and Commercial Fire Protection Projects

- Assembly Hall Airbus A380 – Toulouse France
  - Pump relief valves for fire protection system
- Grey Mare Mining Project – Australia
  - Located in New South Wales
  - Scope of supply included water distribution as well as fire protection valves throughout this mining complex
- BVT Liquefied Natural Gas (LNG)–Costa-Azul/Ensenada, Mexico
  - Scope of supply included water distribution as well as fire protection valves throughout this industrial facility
- AKPO Field development project - Nigeria
  - Fire and cooling water systems and high-capacity air release/vacuum breaker valves in nickel aluminum bronze
- Terminal Methanier de Fos-Cavaou
  - Air release/vacuum breaker valves for fire protection system
- Hallandsas Tunnel Project - Pressure reducing valves for fire protection system
- Guangdong LNG Terminal - Pump pressure relief valves for fire protection system



# 100S/2100S — MODEL —

(Full Internal Port)

## Seawater Service Hytrol Valve

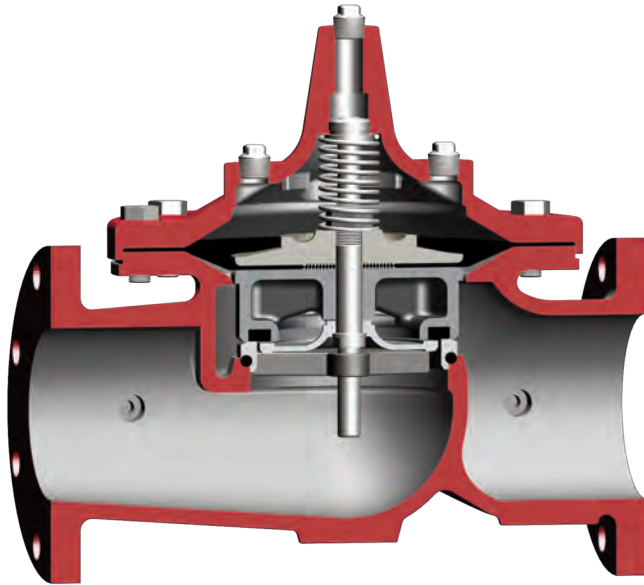

- Drip - tight, positive seating
- Service without removal from line
- Screwed or flanged ends
- Globe or angle pattern
- Every valve factory-tested

The Cla-Val Model 100S/2100S Seawater Service Hytrol Valve is a hydraulically operated, diaphragm actuated, globe or angle pattern valve. It consists of three major components: body, diaphragm assembly and cover. The diaphragm assembly is the only moving part.

The body (ductile iron or cast steel) is epoxy coated and contains a removable seat insert. The diaphragm assembly is guided top and bottom by a precision machined stem. It utilizes a non-wicking diaphragm of nylon fabric bonded with synthetic rubber. A resilient synthetic rubber disc retained on three and one half sides by a disc retainer forms a drip-tight seal with the renewable seat when pressure is applied above the diaphragm.

The Model 100S/2100S Seawater Service Hytrol Valve is the basic valve used for seawater applications. It is the valve of choice for system applications requiring deluge, pressure regulation, pressure relief, solenoid operation, rate of flow control, liquid level control or check valve operation. The rugged simplicity of design and packless construction assure a long life of dependable, trouble-free operation. It is available in various materials and in a full range of sizes, with either screwed or flanged ends. Its applications are unlimited.

### Principle of Operation

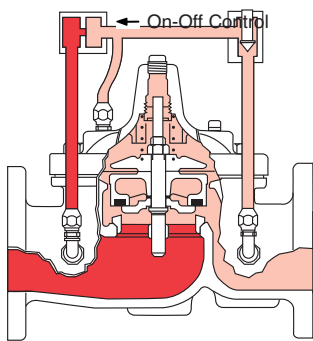

#### Full Open Operation

When pressure in the cover chamber is relieved to a zone of lower pressure, the line pressure at the valve inlet opens the valve, allowing full flow.

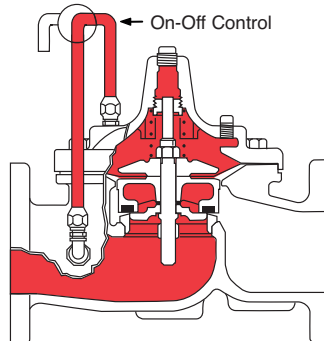

#### Tight Closing Operation

When pressure from the valve inlet is applied to the cover chamber, the valve closes drip-tight.

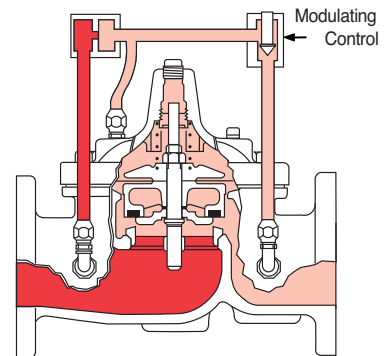

#### Modulating Action

The valve holds any intermediate position when operating pressures are equal above and below the diaphragm. A Cla-Val "modulating" pilot control will allow the valve to automatically compensate for line pressure changes.

## Specifications

### Available Sizes

Pattern	Threaded	Flanged	Grooved End
Globe	1" - 3"	1" - 36"	1½"-2"- 2½"- 3"- 4"- 6"- 8"
Angle	1" - 3"	2" - 24"	2" - 3" - 4"

### Operating Temp. Range

Fluids
-40° to 180° F

### Pressure Ratings (Recommended Maximum Pressure - psi)

Valve Body & Cover		Pressure Class				
		Flanged			Grooved	Threaded
Grade	Material	ANSI Standards*	150 Class	300 Class	300 Class	End‡ Details
ASTM A536	Ductile Iron	B16.42	250	400	400	400
ASTM A216-WCB	Cast Steel	B16.5	285	400	400	400
ASTM B62	Bronze	B16.24	225	400	400	400

Note: \* ANSI standards are for flange dimensions only.  
 Flanged valves are available faced but not drilled.  
 ‡ End Details machined to ANSI B2.1 specifications.  
**Valves for higher pressure are available; consult factory for details**

### Materials

Component	Standard Material Combinations					
Body & Cover	Ductile Iron	Cast Steel	Bronze	Stainless Steel Type 316	Ni. AL. Bronze	Super Duplex Stainless Steel
Available Sizes	1¼" - 36"	1¼" - 16"	1¼" - 16"	1¼" - 16"	1¼" - 16"	1¼" - 16"
Disc Retainer & Diaphragm Washer	Cast Iron	Cast Steel	Bronze	Bronze	Monel	Super Duplex Stainless Steel
Trim: Disc Guide, Seat & Cover Bearing	Bronze is Standard Stainless Steel is optional					
Disc	Buna-N® Rubber					
Diaphragm	Nylon Reinforced Buna-N® Rubber					
Stem, Nut & Spring	Stainless Steel					

For material options not listed, consult factory.  
 Cla-Val manufactures valves in more than 50 different alloys.

For assistance in selecting appropriate valve options or valves manufactured with special design requirements, please contact our Regional Sales Office or Factory.

### Purchase Specifications

The Model 100S/2100S shall be a hydraulically operated, diaphragm-actuated, globe or angle pattern valve. It shall contain a resilient, synthetic rubber disc, having a rectangular cross-section, contained on three and one-half sides by a disc retainer and disc guide, forming a tight seal against a single removable seat insert. The diaphragm assembly, containing a valve stem, shall be fully guided at both ends by a bearing in the valve cover and an integral bearing in the valve seat. This diaphragm assembly shall be the only moving part and shall form a sealed chamber in the upper portion of the valve, separating operating pressure from line pressure. The diaphragm shall consist of nylon fabric bonded with synthetic rubber and shall not be used as a seating surface. Packing glands or stuffing boxes are not permitted and there shall be no pistons operating the valve or its pilot controls. All necessary repairs shall be possible without removing the valve from the line. All materials shall be compatible with seawater. Valve shall be Model 100S/2100S manufactured by Cla-Val, Newport Beach, CA 92659-0325

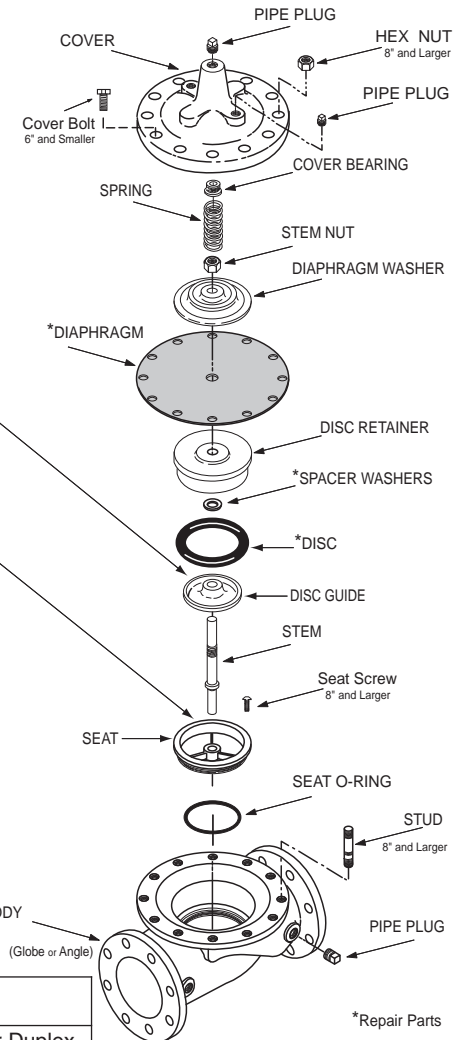

### When Ordering, Please Specify:

1. Model No. 100S or No. 2100S
2. Valve Size
3. Pattern - Globe or Angle
4. Pressure Class
5. Screwed or Flanged
6. Temperature and fluid to be handled.
7. Static and Flowing Line Pressure.
8. Body & Trim Material
9. Desired Options
10. When Vertically Installed

Valve Size		Inches	1	1¼	1½	2	2½	3	4	6	8	10	12	14	16	18	20	24	30	36
		mm.	25	32	40	50	65	80	100	150	200	250	300	350	400	450	500	600	750	900
C <sub>V</sub> Factor	Globe Pattern	Gal./Min. (gpm.)	13.3	30	32	54	85	115	200	440	770	1245	1725	2300	3130	3725	5345	7655	10150	14020
		Litres/Sec. (l/s.)	3.2	7.2	7.7	13	20	28	48	106	185	299	414	552	752	894	1286	1837	2436	3200
	Angle Pattern	Gal./Min. (gpm.)	27	27	29	61	101	139	240	541	990	1575	2500*	3060*	4200*	—	—	9950*	—	—
		Litres/Sec. (l/s.)	6.5	6.5	7	15	24	33	58	130	238	378	600	734	1008	—	—	2388	—	—
Equivalent Length of Pipe	Globe Pattern	Feet (ft.)	23	19	37	51	53	85	116	211	291	347	467	422	503	612	595	628	1181	2285
		Meters (m.)	7.1	5.7	12	15.5	16	26	35	64	89	106	142	129	154	187	181	192	552	569
	Angle Pattern	Feet (ft.)	28	28	46	40	37	58	80	139	176	217	222*	238*	247*	—	—	372*	—	—
		Meters (m.)	8.7	8.7	14	12	11	18	25	43	54	66	68	73	75	—	—	113	—	—
K Factor	Globe Pattern		6.1	3.6	5.9	5.6	4.6	6.0	5.9	6.2	6.1	5.8	6.1	5.0	5.2	5.2	4.6	4.0	5.3	7.8
	Angle Pattern		4.4	4.4	7.1	4.4	3.3	4.1	4.1	4.1	4.1	3.7	3.6	2.9	2.8	2.6	—	—	2.4	—
Liquid Displaced from Cover Chamber When Valve Opens	Fl. Oz		—	—	—	—	—	—	—	—	—	—	—	—	—	—	—	—	—	—
	U.S. Gal.		.02	.02	.02	.03	.04	.08	.17	.53	1.26	2.51	4.0	6.5	9.6	11	12	29	42	90
	ml		20.7	75.7	75.7	121	163	303	643	—	—	—	—	—	—	—	—	—	—	—
	Litres		—	—	—	—	—	—	—	2.0	4.8	9.5	15.1	24.6	36.2	41.6	45.4	109.8	197	340

**C<sub>V</sub> Factor**

Formulas for computing C<sub>V</sub> Factor, Flow (Q) and Pressure Drop (ΔP):

$$C_V = \frac{Q}{\sqrt{\Delta P}} \quad Q = C_V \sqrt{\Delta P} \quad \Delta P = \left(\frac{Q}{C_V}\right)^2$$

**K Factor (Resistance Coefficient)**

The Value of K is calculated from the formula:  $K = \frac{894d^4}{C_V^2}$  (U.S. system units)

**Equivalent Length of Pipe**

Equivalent lengths of pipe (L) are determined from the formula:  $L = \frac{Kd}{12f}$  (U.S. system units)

**Fluid Velocity**

Fluid velocity can be calculated from the following formula:  $V = \frac{.4085 Q}{d^2}$  (U.S. system units)

**Where:**

C<sub>V</sub> = U.S. (gpm) @ 1 psi differential at 60° F water  
or  
= (l/s) @ 1 bar (14.5 PSIG) differential at 15° C water

d = inside pipe diameter of Schedule 40 Steel Pipe (inches)

f = friction factor for clean, new Schedule 40 pipe (dimensionless) (from Cameron Hydraulic Data, 18th Edition, P 3-119)

K = Resistance Coefficient (calculated)

L = Equivalent Length of Pipe (feet)

Q = Flow Rate in U.S. (gpm) or (l/s)

V = Fluid Velocity (feet per second) or (meters per second)

ΔP = Pressure Drop in (psi) or (bar)

\*Estimated

**Model 100-01 Flow Chart** (Based on normal flow through a wide open valve)

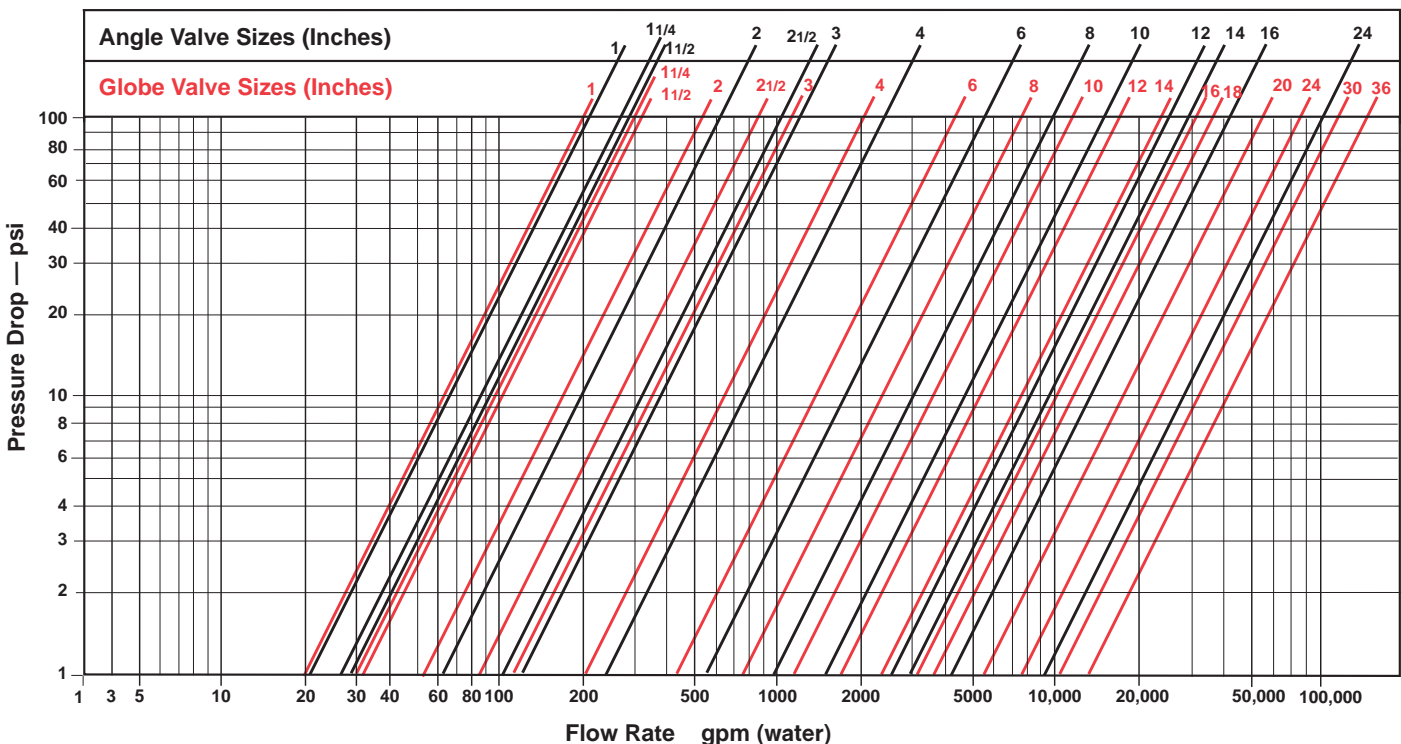

## Dimensions

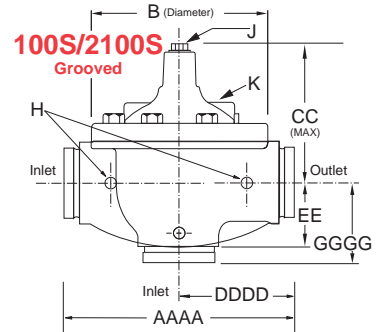
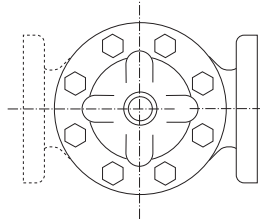
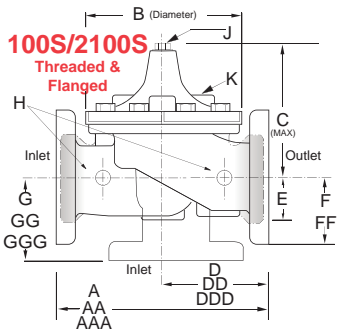

Valve Size (Inches)	1	1 1/4	1 1/2	2	2 1/2	3	4	6	8	10	12	14	16	18	20	24	30	36
A Threaded	7.25	7.25	7.25	9.38	11.00	12.50	—	—	—	—	—	—	—	—	—	—	—	—
AA 150 ANSI	—	—	8.50	9.38	11.00	12.00	15.00	20.00	25.38	29.75	34.00	39.00	41.38	46.00	52.00	61.50	63.00	76.00
AAA 300 ANSI	—	—	9.00	10.00	11.62	13.25	15.62	21.00	26.38	31.12	35.50	40.50	43.50	47.64	53.62	63.24	64.50	76.00
AAAA Grooved End	—	—	8.50	9.00	11.00	12.50	15.00	20.00	25.38	—	—	—	—	—	—	—	—	—
B Dia.	5.62	5.62	5.62	6.62	8.00	9.12	11.50	15.75	20.00	23.62	28.00	32.75	35.50	41.50	45.00	53.16	56.00	66.00
C Max.	5.50	5.50	5.50	6.50	7.56	8.19	10.62	13.38	16.00	17.12	20.88	24.19	25.00	39.06	41.90	43.93	54.60	61.50
CC Max. Grooved End	—	—	4.75	5.75	6.88	7.25	9.31	12.12	14.62	—	—	—	—	—	—	—	—	—
D Threaded	3.25	3.25	3.25	4.75	5.50	6.25	—	—	—	—	—	—	—	—	—	—	—	—
DD 150 ANSI	—	—	4.00	4.75	5.50	6.00	7.50	10.00	12.69	14.88	17.00	19.50	20.81	—	—	30.75	—	—
DDD 300 ANSI	—	—	4.25	5.00	5.88	6.38	7.88	10.50	13.25	15.56	17.75	20.25	21.62	—	—	31.62	—	—
DDDD Grooved End	—	—	4.75	—	6.00	7.50	—	—	—	—	—	—	—	—	—	—	—	—
E	1.12	1.12	1.12	1.50	1.69	2.06	3.19	4.31	5.31	9.25	10.75	12.62	15.50	12.95	15.00	17.75	21.31	24.56
EE Grooved End	—	—	2.00	2.50	2.88	3.12	4.25	6.00	7.56	—	—	—	—	—	—	—	—	—
F 150 ANSI	—	—	2.50	3.00	3.50	3.75	4.50	5.50	6.75	8.00	9.50	10.50	11.75	15.00	16.50	19.25	22.50	25.60
FF 300 ANSI	—	—	3.06	3.25	3.75	4.13	5.00	6.25	7.50	8.75	10.25	11.50	12.75	15.00	16.50	19.25	24.00	25.60
G Threaded	1.88	1.88	1.88	3.25	4.00	4.50	—	—	—	—	—	—	—	—	—	—	—	—
GG 150 ANSI	—	—	4.00	3.25	4.00	4.00	5.00	6.00	8.00	8.62	13.75	14.88	15.69	—	—	22.06	—	—
GGG 300 ANSI	—	—	4.25	3.50	4.31	4.38	5.31	6.50	8.50	9.31	14.50	15.62	16.50	—	—	22.90	—	—
GGGG Grooved End	—	—	—	3.25	—	4.25	5.00	—	—	—	—	—	—	—	—	—	—	—
H NPT Body Tapping	.375	.375	.375	.375	.50	.50	.75	.75	1	1	1	1	1	1	1	1	2	2
J NPT Cover Center Plug	.25	.25	.25	.50	.50	.50	.75	.75	1	1	1.25	1.5	2	1.5	1.5	1.5	2	2
K NPT Cover Tapping	.375	.375	.375	.375	.50	.50	.75	.75	1	1	1	1	1	1	1	1	2	2
Valve Stem Internal Thread UNF	10-32	10-32	10-32	10-32	10-32	1/4-28	1/4-28	3/8-24	3/8-24	3/8-24	3/8-24	3/8-24	3/8-24	1/2-20	3/4-16	3/4-16	3/4-16	3/4-16
Stem Travel	0.4	0.4	0.4	0.6	0.7	0.8	1.1	1.7	2.3	2.8	3.4	4.0	4.5	5.1	5.63	6.75	7.5	8.5
Approx. Ship Wt. Lbs.	15	15	15	35	50	70	140	285	500	780	1165	1600	2265	2982	3900	6200	7703	11720

Note: The top two flange holes on valve size 36 are threaded to 1 1/2"-6 UNC.

Valve Size (mm)	25	32	40	50	65	80	100	150	200	250	300	350	400	450	500	600	750	900
A Threaded	184	184	184	238	279	318	—	—	—	—	—	—	—	—	—	—	—	—
AA 150 ANSI	—	—	216	238	279	305	381	508	645	756	864	991	1051	1168	1321	1562	1600	1930
AAA 300 ANSI	—	—	229	254	295	337	397	533	670	790	902	1029	1105	1210	1362	1606	1638	1930
AAAA Grooved End	—	—	216	228	279	318	381	508	645	—	—	—	—	—	—	—	—	—
B Dia.	143	143	143	168	203	232	292	400	508	600	711	832	902	1054	1143	1350	1422	1676
C Max.	140	140	140	165	192	208	270	340	406	435	530	614	635	992	1064	1116	1387	1562
CC Max. Grooved End	—	—	120	146	175	184	236	308	371	—	—	—	—	—	—	—	—	—
D Threaded	83	83	83	121	140	159	—	—	—	—	—	—	—	—	—	—	—	—
DD 150 ANSI	—	—	102*	121	140	152	191	254	322	378	432	495	528	—	—	781	—	—
DDD 300 ANSI	—	—	108*	127	149	162	200	267	337	395	451	514	549	—	—	803	—	—
DDDD Grooved End	—	—	—	121	—	152	191	—	—	—	—	—	—	—	—	—	—	—
E	29	29	29	38	43	52	81	110	135	235	273	321	394	329	381	451	541	624
EE Grooved End	—	—	52	64	73	79	108	152	192	—	—	—	—	—	—	—	—	—
F 150 ANSI	—	—	64	76	89	95	114	140	171	203	241	267	298	381	419	489	572	650
FF 300 ANSI	—	—	78	83	95	105	127	159	191	222	260	292	324	381	419	489	610	650
G Threaded	48	48	48	83	102	114	—	—	—	—	—	—	—	—	—	—	—	—
GG 150 ANSI	—	—	102*	83	102	102	127	152	203	219	349	378	399	—	—	560	—	—
GGG 300 ANSI	—	—	102*	89	110	111	135	165	216	236	368	397	419	—	—	582	—	—
GGGG Grooved End	—	—	—	83	—	108	127	—	—	—	—	—	—	—	—	—	—	—
H NPT Body Tapping	.375	.375	.375	.375	.50	.50	.75	.75	1	1	1	1	1	1	1	1	2	2
J NPT Cover Center Plug	.25	.25	.25	.50	.50	.50	.75	.75	1	1	1.25	1.5	2	1.5	1.5	1.5	2	2
K NPT Cover Tapping	.375	.375	.375	.375	.50	.50	.75	.75	1	1	1	1	1	1	1	1	2	2
Valve Stem Internal Thread UNF	10-32	10-32	10-32	10-32	10-32	1/4-28	1/4-28	3/8-24	3/8-24	3/8-24	3/8-24	3/8-24	3/8-24	1/2-20	3/4-16	3/4-16	3/4-16	3/4-16
Stem Travel	10	10	10	15	18	20	28	43	58	71	86	102	114	130	143	171	190	216
Approx. Ship Wt. Kgs.	7	7	7	16	23	32	64	129	227	354	528	726	1027	1353	1769	2812	3494	5316

Cla-Val Control Valves operate with maximum efficiency when mounted in horizontal piping with the main valve cover UP, however, other positions are acceptable. Due to component size and weight of 8 inch and larger valves, installation with cover UP is advisable. We recommend isolation valves be installed on inlet and outlet for maintenance. Adequate space above and around the valve for service personnel should be considered essential. A regular maintenance program should be established based on the specific application data. However, we recommend a thorough inspection be done at least once a year. Consult factory for specific recommendations.

# 100G/2100G Fresh Water Version

# 100GS/2100GS Seawater Version

MODELS



## Deluge Valve



- **UL Listed / ULC Listed**
- **Globe or Angle Pattern**
- **Proven Reliable Design**



**Type Approved**

The Cla-Val Model 100G/2100G Deluge Valve is designed for use in controlling water flow to Deluge, Pre-Action, or Foam-Water type fire protection sprinkler systems. This valve is UL Listed in "Special Systems Water Control Valves Class I (VLFT) for both vertical and horizontal installation applications. The Model 100G/2100G is UL Listed for operation manually, electronically, with hydraulic or pneumatic pilot control system for a wet pilot line of sprinklers. It is a hydraulically-operated, diaphragm-actuated, globe or angle pattern Deluge Valve. It consists of three major components: the body, the cover, and the diaphragm assembly. The only moving part is the diaphragm assembly. Packless construction and simplicity of design assures long service life and dependable low maintenance for this valve. All ferrous parts are fusion epoxy coated internally and externally for added corrosion resistance, along with a Dura Kleen™ stem.

**The 100GS/2100GS is manufactured in materials suitable for seawater.**

### Typical Application

The Model 100G/2100G is installed to control the water flow to the sprinklers in Deluge, Pre-Action, or Foam-Water type systems. A simplified system is used to illustrate typical operation.

The Model 100G/2100G Deluge Valve (3) is maintained in the closed position by means of system water pressure controlled by a pilot control (4). When the pilot control valve receives a signal from the fire detection system, it allows the deluge valve to open. Firefighting water (1) then enters system piping (5) and discharges from sprinklers (6).

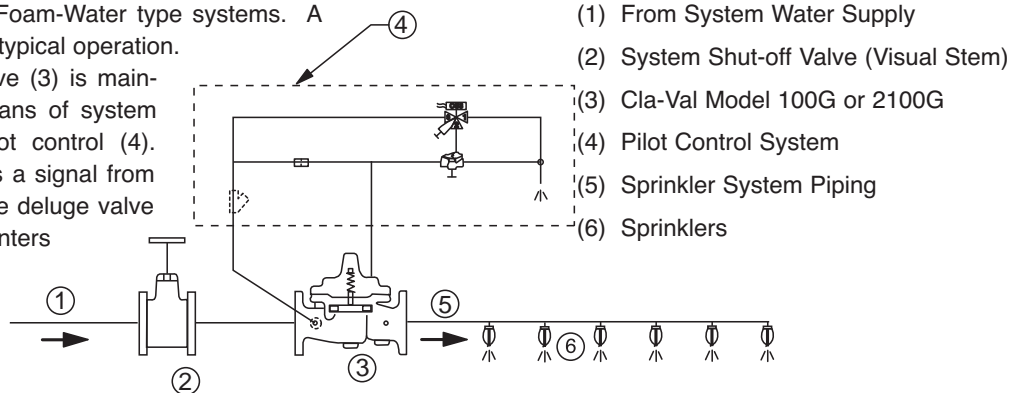

### Specifications

**Sizes** Globe: 3" – 12" • Angle: 3" – 12"

Ductile Iron 150 ANSI B16.42 flanged

**End Details** Cast Steel 150 ANSI B16.5 flanged

150 class, 250 psi maximum (Ductile Iron)

150 class, 285 psi maximum (All other materials)

**Pressure Rating** 300 class, 300 psi maximum (All materials)

Water, to 180°F MAX.

**Temperature Range** **Main Valve Body & Cover:**

**Materials**

- Ductile Iron ASTM A-536\* **UL, ULC**
- Cast Steel ASTM A216-WCB\* **UL, ULC**
- Nickel Aluminum Bronze ASTM B148 **UL, ULC**
- Naval Bronze ASTM B61 **UL, ULC**
- 316 Stainless Steel - ASTM A743 Grades CF3M and CFM8
- Super Austenitic Stainless Steel - ASTM A351 Grade CK3MCuN (SMO 254)
- Super Duplex Stainless Steel - ASTM A890 Grade 5A (CE3MN)

**Main Valve Internal Trim:**

Bronze ASTM B61 • Monel QQ-N-281 Class B

**Diaphragm and Disc:**

Buna-N® synthetic rubber

\*Internally & Externally Epoxy Coated

### Specifications Seawater Service Option

**Sizes** Globe: 3" - 12" flanged

Angle: 3" - 12" flanged

Consult factory for materials and flange ratings.

### When Ordering, Please Specify

1. Model No. 100GS or 2100GS
2. Size
3. Body and Cover Material
4. Globe or Angle Pattern
5. Pressure Class
6. Internal Trim Material

\*optional Teflon™ coated seat upon request.

To calculate the maximum wet sprinkler pilot height above the valve, use the graph below.

**CLA-VAL 100G & 2100G  
CLA-VAL 100GS & 2100GS  
WET PILOT LINE DESIGN CRITERIA**  
For All Valve Sizes

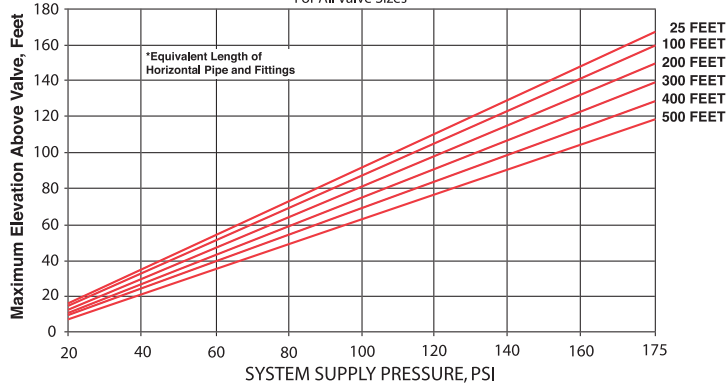

\*Based on 1/2 inch schedule 40 pipe, C=120  
If system supply pressure is variable, use minimum value

WET PILOT LINE EQUIVALENT LENGTHS MUST BE RECALCULATED FOR SYSTEMS USING PILOT LINE SIZES AND FITTINGS OTHER THAN THAT SPECIFIED IN THE ABOVE GRAPH

**Functional Data**

Valve Size	Inches	3	4	6	8	10	12	
	mm	80	100	150	200	250	300	
C <sub>v</sub> Factor	Globe Pattern	Gal./Min. (gpm)	115	200	440	770	1245	1725
		Litres/Sec. (l/s)	27.6	48	105.6	184.8	299	414
C <sub>v</sub> Factor	Angle Pattern	Gal./Min. (gpm)	139	240	541	990	1575	2500*
		Litres/Sec. (l/s)	33.4	58	130	238	378	600

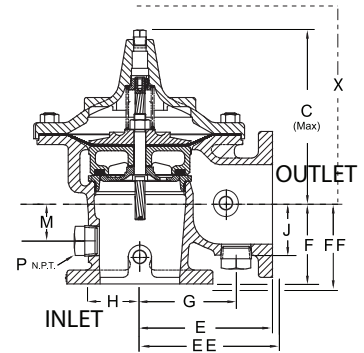
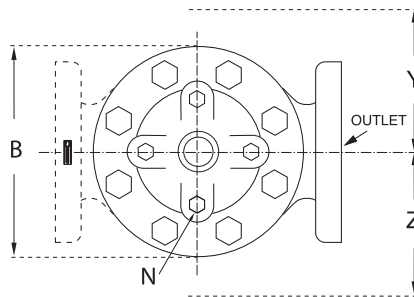
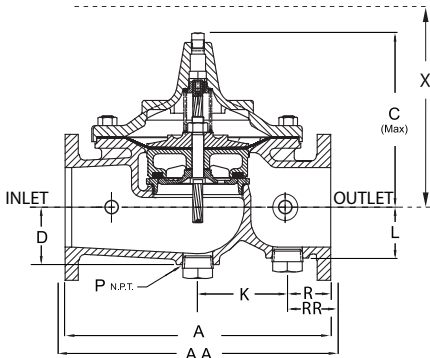

Valve Size (In.)	3	4	6	8	10	12
A 150 ANSI	12.00	15.00	20.00	25.38	29.75	—
AA 300 ANSI	13.25	15.62	21.00	26.38	31.12	34.00
B Dia.	9.12	11.50	15.75	20.00	23.62	35.50
C Max.	8.19	10.62	13.38	16.00	17.12	—
D	2.56	3.19	4.31	5.16	8.50	28.00
E 150 ANSI	7.00	8.50	10.00	12.69	14.88	20.88
EE 300 ANSI	--	8.81	10.50	13.19	--	—
F 150 ANSI	4.00	4.97	6.00	8.00	8.62	—
FF 300 ANSI	--	5.28	6.50	8.50	--	17.00
G	4.75	5.94	7.25	8.50	10.50	17.75
H	2.69	2.81	3.88	5.31	6.56	—
J	2.56	2.81	3.81	4.81	5.81	10.75
K	7.00	4.03	6.75	17.00	15.50	—
L	2.56	2.81	3.81	4.81	8.50	9.50
M	1.75	2.41	2.75	4.00	4.24	10.25
N NPT	1/2 - 14	3/4 - 14	3/4 - 14	1 - 11-1/2	1 - 11-1/2	—
P NPT	1-1/4 - 11-1/2	2 - 11-1/2				
R 150 ANSI	2.50	3.47	3.25	4.19	7.12	14.50
RR 300 ANSI	3.12	3.78	3.75	4.69	7.81	—
X Pilot System	15.00	17.00	29.00	31.00	33.00	1
Y Pilot System	11.00	12.00	20.00	22.00	24.00	1.25
Z Pilot System	11.00	12.00	20.00	22.00	24.00	1

Valve Size (mm)	80	100	150	200	250	300
A 150 ANSI	305	381	508	645	756	—
AA 300 ANSI	337	397	533	670	791	864
B Dia.	232	292	400	508	600	902
C Max.	208	270	340	406	435	—
D	65	81	110	131	216	711
E 150 ANSI	178	216	254	322	378	530
EE 300 ANSI	--	224	267	350	--	—
F 150 ANSI	102	126	152	203	219	—
FF 300 ANSI	--	134	165	216	--	432
G	121	151	184	216	267	451
H	68	71	99	135	167	—
J	65	71	97	122	148	273
K	178	102	171	432	394	—
L	65	71	97	122	216	241
M	45	61	70	102	108	260
N NPT	1/2 - 14	3/4 - 14	3/4 - 14	1 - 11 1/2	1 - 11-1/2	—
P NPT	1-1/4 - 11-1/2	2 - 11-1/2				
R 150 ANSI	64	88	83	106	181	368
RR 300 ANSI	79	96	95	119	198	—
X Pilot System	381	432	737	787	838	1
Y Pilot System	279	305	508	559	610	1.25
Z Pilot System	279	305	508	559	610	1



E-100G & 100GS (R-05/2017)

**CLA-VAL**

1701 Placentia Avenue • Costa Mesa CA 92627

800-942-6326 • Fax: 949-548-5441 • Web Site: cla-val.com • E-mail: info@cla-val.com

**CLA-VAL CANADA**  
4687 Christie Drive  
Beamsville, Ontario  
Canada L0R 1B4  
Phone: 905-563-4963  
Fax: 905-563-4040  
E-mail sales@cla-val.ca

**CLA-VAL EUROPE**  
Chemin des Mésanges 1  
CH-1032 Romanel/  
Lausanne, Switzerland  
Phone: 41-21-643-15-55  
Fax: 41-21-643-15-50  
E-mail: cla-val@cla-val.ch

**CLA-VAL UK**  
Dainton House, Goods Station Road  
Tunbridge Wells  
Kent TN1 2 DH England  
Phone: 44-1892-514-400  
Fax: 44-1892-543-423  
E-mail: info@cla-val.co.uk

**CLA-VAL FRANCE**  
Porte du Grand Lyon 1  
ZAC du Champ du Périer  
France - 01700 Neyron  
Phone: 33-4-72-25-92-93  
Fax: 33-4-72-25-04-17  
E-mail: cla-val@cla-val.fr

**CLA-VAL PACIFIC**  
45 Kennaway Road  
Woolston, Christchurch, 8023  
New Zealand  
Phone: 64-39644860  
www.cla-valpacific.com  
E-mail: info@cla-valpacific.com

# Ti 100GS — MODEL —

## Seawater Version



## Anti-Cavitation Hytrol Valve

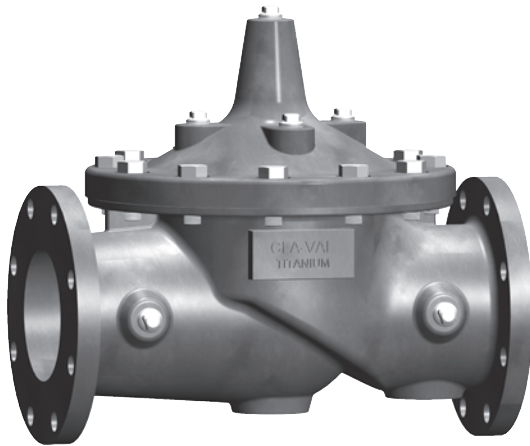

- UL Listed / ULC Listed
- ABS Approved
- Globe Pattern
- Proven Reliable Design



Type Approved

The Cla-Val Model Ti 100GS Deluge Valve is designed for use in controlling water flow to Deluge, Pre-Action, or Foam-Water type fire protection sprinkler systems. This valve is U.L. Listed in "Special Systems Water Control Valves Class I (VLFT)". The Model Ti 100GS is a hydraulically-operated, diaphragm-actuated, globe or angle pattern Deluge Valve. It consists of three major components: the body, the cover, and the diaphragm assembly. The only moving part is the diaphragm assembly. Packless construction and simplicity of design assures long service life and dependable low maintenance for this valve.

The Ti 100GS are manufactured in materials suitable for seawater.

### Typical Application

The Model Ti 100GS is installed to control the water flow to the sprinklers in Deluge, Pre-Action, or Foam-Water type systems. A simplified system is used to illustrate typical operation. The Model Ti 100GS Deluge Valve (3) is maintained in the closed position by means of system water pressure controlled by a pilot control (4). When the pilot control valve receives a signal from the fire detection system, it allows the deluge valve to open. Firefighting water (1) then enters system piping (5) and discharges from sprinklers (6).

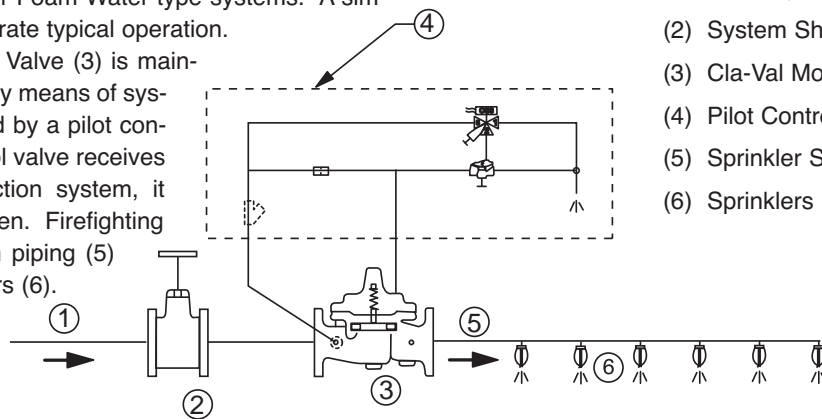

- (1) From System Water Supply
- (2) System Shut-off Valve (Visual Stem)
- (3) Cla-Val Model Ti 100GS
- (4) Pilot Control System
- (5) Sprinkler System Piping
- (6) Sprinklers

### Specifications

<b>Sizes:</b>	Globe: 3" - 4" - 6"
<b>End Details:</b>	ISO 7005-2 PN 10-16 150 ANSI B16.42 flanged
<b>Pressure Rating:</b>	26 bar max.
<b>Temperature Range:</b>	Water, to 180°F MAX.
<b>Material:</b>	<b>Main Valve Body &amp; Cover</b> Titanium ASTM B367 Grade C2  <b>Standard Main Valve Trim:</b> Titanium ASTM B367, Grade C2  <b>Diaphragm and Disc:</b> Buna-N, synthetic rubber

### Friction Loss

For use in hydraulically calculated systems, friction loss equivalent to:

Ti 100GS (Globe):

- 3" Size=42 Ft. of 3" Pipe
- 4" Size=92 Ft. of 4" Pipe
- 6" Size=116 Ft. of 6" Pipe

### When Ordering, Please Specify

1. Catalog No. Ti 100GS
2. Size
3. Pressure Class
4. Internal Trim Material

### Specifications Ti 100GS Seawater Service Option

Sizes Globe: 3" - 4" - 6" flanged

"Fluid Control at It's Best"

To calculate the maximum wet sprinkler pilot height above the valve, use the graph below.

**CLA-VAL Ti 100GS**  
**WET PILOT LINE DESIGN CRITERIA**  
 For All Valve Sizes

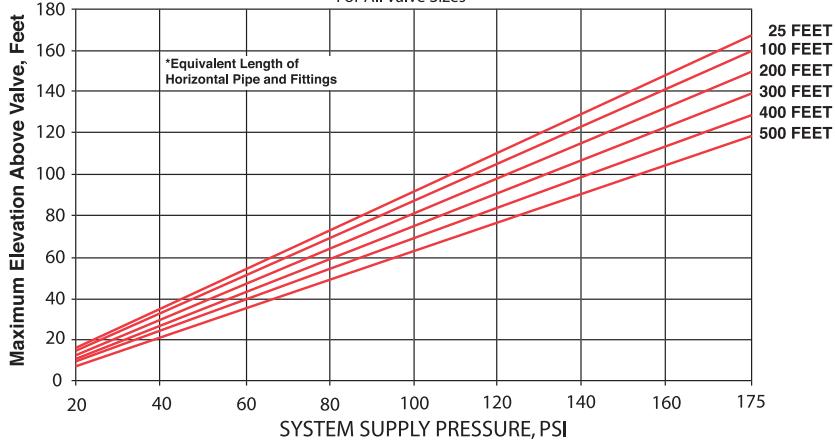

\*Based on 1/2 inch schedule 40 pipe, C=120  
 If system supply pressure is variable, use minimum value  
 WET PILOT LINE EQUIVALENT LENGTHS MUST BE RECALCULATED FOR SYSTEMS USING  
 PILOT LINE SIZES AND FITTINGS OTHER THAN THAT SPECIFIED IN THE ABOVE GRAPH

**Functional Data**

Valve Size		Inches	3	4	6
		mm	80	100	150
C <sub>v</sub> Factor	Globe Pattern	Gal./Min. (gpm)	115	200	440
		Litres/Sec. (l/s)	27.6	48	105.6

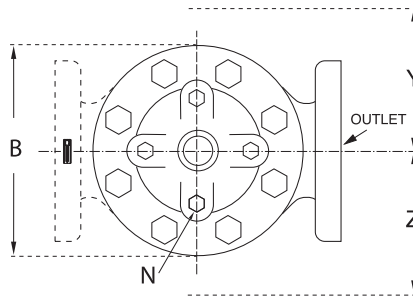
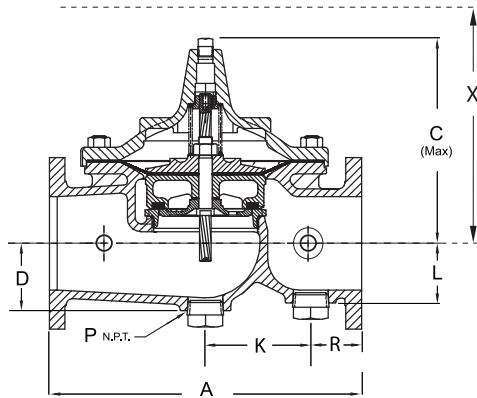

Valve Size (Inches)	3	4	6
A 150 ANSI	12.00	15.00	20.00
B Dia.	9.12	11.50	15.75
C Max.	8.19	10.62	13.38
D	2.56	3.19	4.31
K	7.00	4.03	6.75
L	2.56	2.81	3.81
N NPT	1/2"-14	3/4"-14	3/4"-14
P NPT	1 1/4"-11 1/2	2"-11 1/2"	2"-11 1/2"
R 150 ANSI	2.50	3.47	3.25
X Pilot System	15.00	17.00	29.00
Y Pilot System	11.00	12.00	20.00
Z Pilot System	11.00	12.00	20.00

Valve Size (mm)	80	100	150
A 150 ANSI	305	381	508
B Dia.	232	292	400
C Max.	208	270	340
D	65	81	110
K	178	102	171
L	65	71	97
N NPT	1/2"-14	3/4"-14	3/4"-14
P NPT	1 1/4"-11 1/2	2"-11 1/2"	2"-11 1/2"
R 150 ANSI	64	88	83
X Pilot System	381	432	737
Y Pilot System	279	305	508
Z Pilot System	279	305	508



**CLA-VAL**

1701 Placentia Avenue • Costa Mesa CA 92627  
 800-942-6326 • Fax: 949-548-5441 • Web Site: cla-val.com • E-mail: info@cla-val.com

**CLA-VAL CANADA**  
 4687 Christie Drive  
 Beamsville, Ontario  
 Canada L0R 1B4  
 Phone: 905-563-4963  
 Fax: 905-563-4040  
 E-mail sales@cla-val.ca

**CLA-VAL EUROPE**  
 Chemin des Mésanges 1  
 CH-1032 Romanel/  
 Lausanne, Switzerland  
 Phone: 41-21-643-15-55  
 Fax: 41-21-643-15-50  
 E-mail: cla-val@cla-val.ch

**CLA-VAL UK**  
 Dainton House, Goods Station Road  
 Tunbridge Wells  
 Kent TN1 2 DH England  
 Phone: 44-1892-514-400  
 Fax: 44-1892-543-423  
 E-mail: info@cla-val.co.uk

**CLA-VAL FRANCE**  
 Porte du Grand Lyon 1  
 ZAC du Champ du Périer  
 France - 01700 Neyron  
 Phone: 33-4-72-25-92-93  
 Fax: 33-4-72-25-04-17  
 E-mail: cla-val@cla-val.fr

**CLA-VAL PACIFIC**  
 45 Kennaway Road  
 Woolston, Christchurch, 8023  
 New Zealand  
 Phone: 64-39644860  
 www.cla-valpacific.com  
 E-mail: info@cla-valpacific.com



# Weigh the options

## ***Cla-Val Titanium Valves: the lighter weight alternative with heavyweight capabilities***

The **UL Listed** Cla-Val Model 100GS Ti is ideal for applications where valves are exposed to seawater, chlorine, and other aggressive media. Constructed of a titanium alloy, the 100GS Ti is designed to control water flow to deluge, pre-action or foam-water type fire protection sprinkler systems.

### ***The Titanium Advantage***

- Titanium is as strong as steel but 50% lighter -- a distinct advantage when the valves are installed on offshore platforms or FPSOs
- Titanium is not only high strength, it is also low density and exceptionally corrosion resistant
- Because titanium can withstand harsh environmental conditions, service life is extended, making titanium valves more cost effective than other available options
- Titanium is virtually immune to the following material failures:
  - Corrosion fatigue
  - Erosion
  - Pitting attack
  - Galvanic attack
  - Microbiological corrosion

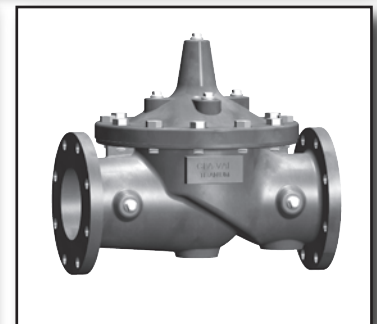
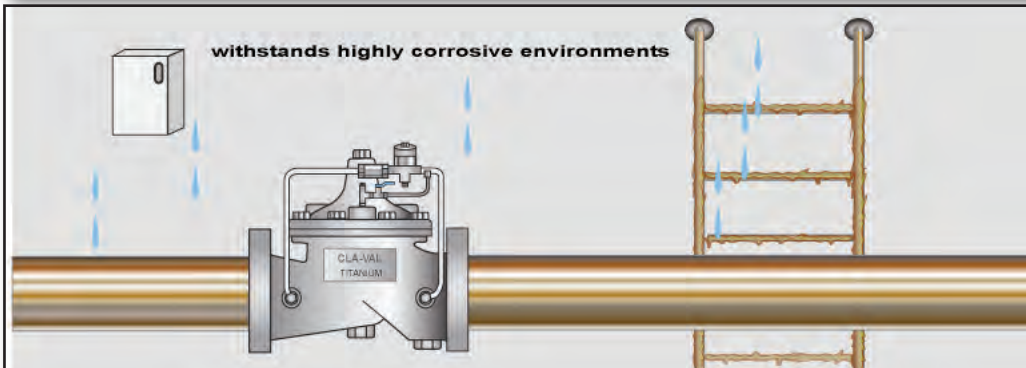

Titanium ASTM B367,  
Grade C2

Available in sizes  
3" through 6"  
Consult factory for  
other sizes

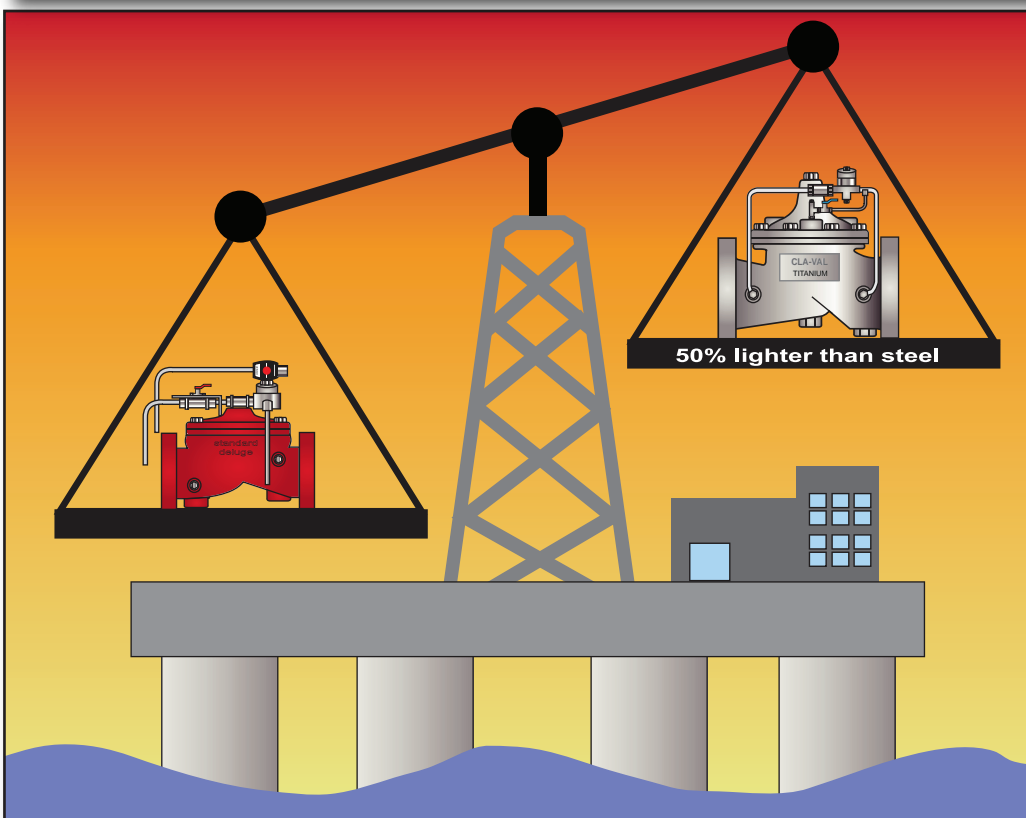

***To learn more, visit  
[www.cla-val.com](http://www.cla-val.com)  
and type 100GS Ti  
in the search field***



# Got Vibration?

***Cla-Val valves with anti-cavitation trim are the ideal solution for applications with a high probability of vibration***

- Cla-Val's patented KO anti-cavitation trim helps protect piping from damage caused by vibration
- Minimizes vibration across the relief valve during pump starts
- Alleviates vibration caused by cavitation when discharging to atmosphere or in other applications with excessive pressure fluctuations

***Other advantages include the following:***

- Special alloys and metals available, including Monel, and 316 Stainless Steel
- Existing Cla-Val control valves can field retrofitted with KO anti-cavitation trim
- Proven track record of trouble-free performance on offshore platforms around the world
- Backed by more than seventy years of industry experience
- Three-year warranty

## Typical Cla-Val Anti-Cavitation Application

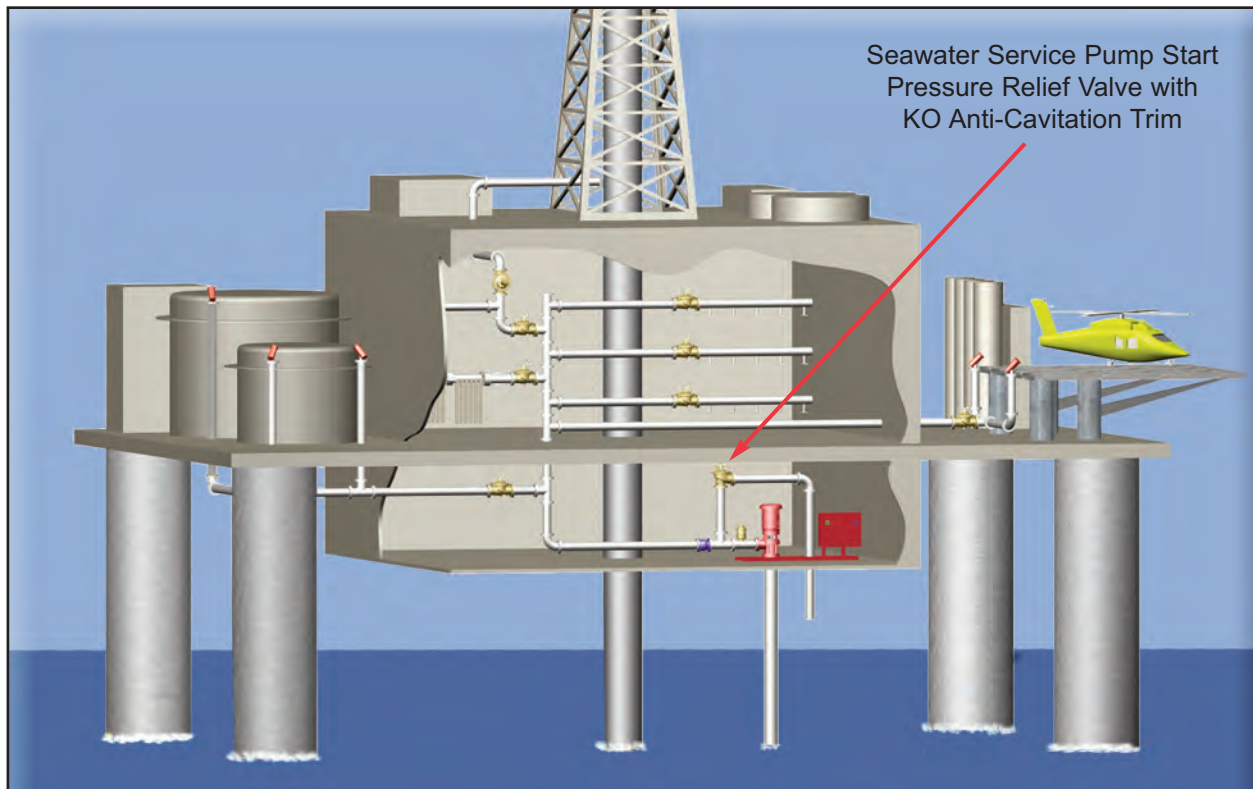

Fire Protection Systems aboard  
Offshore Oil Platforms

*To learn more, visit [www.cla-val.com](http://www.cla-val.com) and  
click the "Vibration" Quick Link*

# 100-01KO — MODEL — (Full Internal Port)



## Anti-Cavitation Hytrol Valve

- Virtually Cavitation Free Operation
- Severe Service Design - High Pressure Differentials
- Reduced Noise and Vibration
- 316 Stainless Steel Disc Guide and Seat Standard
- Drip-Tight, Positive Sealing
- Service Without Removal From Line
- Retrofit to Standard Hytrol Valves

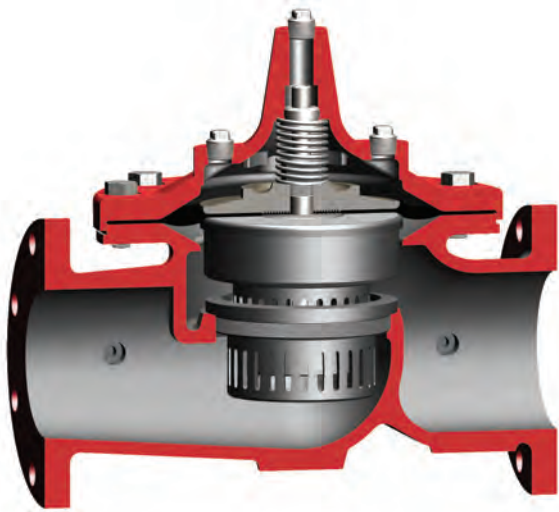

The Cla-Val Model 100-01KO Anti-Cavitation Hytrol Valve is designed for applications where there is a high potential for damage from cavitation. Specify this valve series for a wide variety of control valve applications having pressure differentials up to 300 psid or for relief valves having atmospheric discharge up to 150 psid.

The 100-01KO Hytrol main valve provides optimum internal pressure control through a unique anti-cavitation trim design. Constructed of 316 Stainless Steel, the seat and disc guide trim components feature dual interlocked sleeves containing radial slots that deflect internal flow to impinge upon itself in the center of the flow path, harmlessly dissipating the potential cavitation damage. This unique design also lessens the possibility of fouling if large particles in the water are present due to the large flow path of the radial slots.

The 100-01KO Hytrol is the basic valve used in Cla-Val Automatic Control Valves for high differential applications requiring remote control, pressure regulation, solenoid operation, rate of flow control, or liquid level control.

The Anti-Cavitation Trim components can be retrofitted to existing valves if the application indicates an appropriate need. Please consult factory for details.

### Principle of Operation

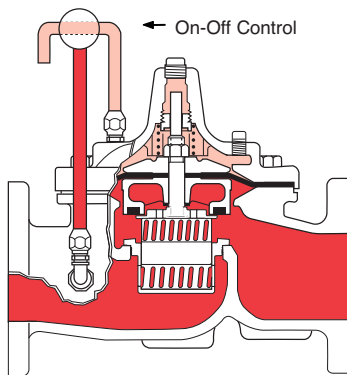

#### Full Open Operation

When pressure in the cover chamber is relieved to a zone of lower pressure, the line pressure at the valve inlet opens the valve, allowing full flow.

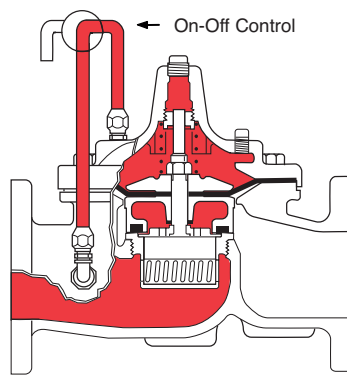

#### Tight Closing Operation

When pressure from the valve inlet is applied to the cover chamber, the valve closes drip-tight.

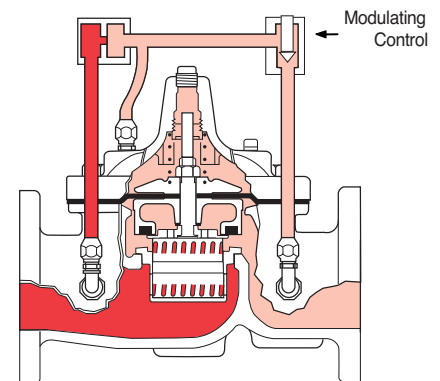

#### Modulating Action

The valve holds any intermediate position when operating pressures are equal above and below the diaphragm. A Cla-Val "Modulating" Pilot Control will allow the valve to automatically compensate for line pressure changes.

# Specifications

Pattern	Globe	Angle	Grooved End
Size	1" - 36"	1" - 16" & 24"	1 1/2" - 8"

# Operating Temp. Range

Fluids
-40 to 180 F



**APPROVED**  
(4" - 24")

# Model 100-01KO

## Pressure Ratings (Recommended Maximum Pressure - psi)

Valve Body & Cover		Pressure Class				
		Flanged			Grooved	Threaded
Grade	Material	ANSI Standards*	150 Class	300 Class	300 Class	End† Details
ASTM A536	Ductile Iron	B16.42	250	400	400	400
ASTM A216-WCB	Cast Steel	B16.5	285	400	400	400
ASTM B62	Bronze	B16.24	225	400	400	400

Note: \* ANSI standards are for flange dimensions only.  
Flanged valves are available faced but not drilled.  
† End Details machined to ANSI B2.1 specifications.

**Valves for higher pressure are available; consult factory for details**

## Materials

Component	Standard Material Combinations		
Body & Cover	Ductile Iron	Cast Steel	Bronze
Available Sizes	1" - 36"	1" - 16"	1" 16"
Disc Retainer & Diaphragm Washer	Cast Iron	Cast Steel	Bronze
Trim: Disc Guide, Seat & Cover Bearing	Stainless Steel is Standard		
Disc	Buna-N® Rubber		
Diaphragm	Nylon Reinforced Buna-N® Rubber		
Stem, Nut & Spring	Stainless Steel		
For material options not listed consult factory.			
Cla-Val manufactures valves in more than 50 different alloys.			

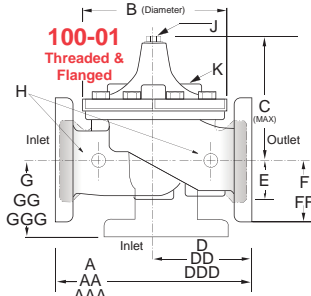

**Note:**  
Consult Factory on 10", 12", 16" angle pattern

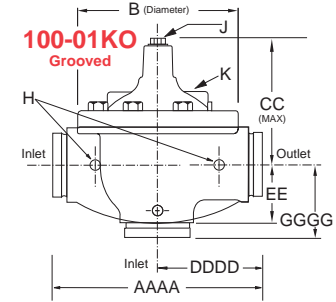
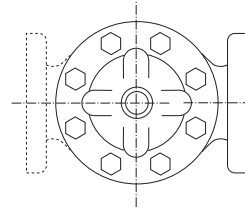

Valve Size (Inches)	1	1 1/4	1 1/2	2	2 1/2	3	4	6	8	10	12	14	16	18	20	24	30	36
A Threaded	7.25	7.25	7.25	9.38	11.00	12.50	—	—	—	—	—	—	—	—	—	—	—	—
AA 150 ANSI	—	—	8.50	9.38	11.00	12.00	15.00	20.00	25.38	29.75	34.00	39.00	41.38	46.00	52.00	61.50	63.00	76.00
AAA 300 ANSI	—	—	9.00	10.00	11.62	13.25	15.62	21.00	26.38	31.12	35.50	40.50	43.50	47.64	53.62	63.24	64.50	76.00
AAAA Grooved End	—	—	8.50	9.00	11.00	12.50	15.00	20.00	25.38	—	—	—	—	—	—	—	—	—
B Dia.	5.62	5.62	5.62	6.62	8.00	9.12	11.50	15.75	20.00	23.62	28.00	32.75	35.50	41.50	45.00	53.16	56.00	66.00
C Max.	5.50	5.50	5.50	6.50	7.56	8.19	10.62	13.38	16.00	17.12	20.88	24.19	25.00	39.06	41.90	43.93	54.60	61.50
CC Max. Grooved End	—	—	4.75	5.75	6.88	7.25	9.31	12.12	14.62	—	—	—	—	—	—	—	—	—
D Threaded	3.25	3.25	3.25	4.75	5.50	6.25	—	—	—	—	—	—	—	—	—	—	—	—
DD 150 ANSI	—	—	4.00	4.75	5.50	6.00	7.50	10.00	12.69	14.88	17.00	19.50	20.81	—	—	30.75	—	—
DDD 300 ANSI	—	—	4.25	5.00	5.88	6.38	7.88	10.50	13.25	15.56	17.75	20.25	21.62	—	—	31.62	—	—
DDDD Grooved End	—	—	—	4.75	—	6.00	7.50	—	—	—	—	—	—	—	—	—	—	—
E	1.12	1.12	1.12	1.50	1.69	2.06	3.19	4.31	5.31	9.25	10.75	12.62	15.50	12.95	15.00	17.75	21.31	24.56
EE Grooved End	—	—	2.00	2.50	2.88	3.12	4.25	6.00	7.56	—	—	—	—	—	—	—	—	—
F 150 ANSI	—	—	2.50	3.00	3.50	3.75	4.50	5.50	6.75	8.00	9.50	10.50	11.75	15.00	16.50	19.25	22.50	25.60
FF 300 ANSI	—	—	3.06	3.25	3.75	4.13	5.00	6.25	7.50	8.75	10.25	11.50	12.75	15.00	16.50	19.25	24.00	25.60
G Threaded	1.88	1.88	1.88	3.25	4.00	4.50	—	—	—	—	—	—	—	—	—	—	—	—
GG 150 ANSI	—	—	4.00	3.25	4.00	4.00	5.00	6.00	8.00	8.62	13.75	14.88	15.69	—	—	—	—	—
GGG 300 ANSI	—	—	4.25	3.50	4.31	4.38	5.31	6.50	8.50	9.31	14.50	15.62	16.50	—	—	—	—	—
GGGG Grooved End	—	—	—	3.25	—	4.25	5.00	—	—	—	—	—	—	—	—	—	—	—
H NPT Body Tapping	.375	.375	.375	.375	.50	.50	.75	.75	1	1	1	1	1	1	1	1	2	2
J NPT Cover Center Plug	.25	.25	.25	.50	.50	.50	.75	.75	1	1	1.25	1.5	2	1	1	1	2	2
K NPT Cover Tapping	.375	.375	.375	.375	.50	.50	.75	.75	1	1	1	1	1	1	1	1	2	2
Stem Travel	0.4	0.4	0.4	0.6	0.7	0.8	1.1	1.7	2.3	2.8	3.4	4.0	4.5	5.1	5.63	6.75	7.5	8.5
Approx. Ship Wt. Lbs.	15	15	15	35	50	70	140	285	500	780	1165	1600	2265	2982	3900	6200	7703	11720
Valve Size (mm)	25	32	40	50	65	80	100	150	200	250	300	350	400	450	500	600	750	900
A Threaded	184	184	184	238	279	318	—	—	—	—	—	—	—	—	—	—	—	—
AA 150 ANSI	—	—	216	238	279	305	381	508	645	756	864	991	1051	1168	1321	1562	1600	1930
AAA 300 ANSI	—	—	229	254	295	337	397	533	670	790	902	1029	1105	1210	1362	1606	1638	1930
AAAA Grooved End	—	—	216	228	279	318	381	508	645	—	—	—	—	—	—	—	—	—
B Dia.	143	143	143	168	203	232	292	400	508	600	711	832	902	1054	1143	1350	1422	1676
C Max.	140	140	140	165	192	208	270	340	406	435	530	614	635	992	1064	1116	1387	1562
CC Max. Grooved End	—	—	120	120	146	175	184	236	308	371	—	—	—	—	—	—	—	—
D Threaded	83	83	83	121	140	159	—	—	—	—	—	—	—	—	—	—	—	—
DD 150 ANSI	—	—	102	121	140	152	191	254	322	378	432	495	528	—	—	781	—	—
DDD 300 ANSI	—	—	108	127	149	162	200	267	337	395	451	514	549	—	—	803	—	—
DDDD Grooved End	—	—	—	121	—	152	191	—	—	—	—	—	—	—	—	—	—	—
E	29	29	29	38	43	52	81	110	135	235	273	321	394	329	381	451	541	624
EE Grooved End	—	—	52	64	73	79	108	152	192	—	—	—	—	—	—	—	—	—
F 150 ANSI	—	—	64	76	89	95	114	140	171	203	241	267	298	381	419	489	572	650
FF 300 ANSI	—	—	78	83	95	105	127	159	191	222	260	292	324	381	419	489	610	650
G Threaded	48	48	48	83	102	114	—	—	—	—	—	—	—	—	—	—	—	—
GG 150 ANSI	—	—	102*	83	102	102	127	152	203	219	349	378	399	—	—	—	—	—
GGG 300 ANSI	—	—	102*	89	110	111	135	165	216	236	368	397	419	—	—	—	—	—
GGGG Grooved End	—	—	—	83	—	108	127	—	—	—	—	—	—	—	—	—	—	—
H NPT Body Tapping	.375	.375	.375	.375	.50	.50	.75	.75	1	1	1	1	1	1	1	1	2	2
J NPT Cover Center Plug	.25	.25	.25	.50	.50	.50	.75	.75	1	1	1.25	1.5	2	1	1	1	2	2
K NPT Cover Tapping	.375	.375	.375	.375	.50	.50	.75	.75	1	1	1	1	1	1	1	1	2	2
Stem Travel	10	10	10	15	18	20	28	43	58	71	86	102	114	130	143	171	190	216
Approx. Ship Wt. Kgs.	7	7	7	16	23	32	64	129	227	354	528	726	1027	1353	1769	2812	3494	5316

Cla-Val Control Valves with KO ANTI-CAVITATION Trim operate with maximum efficiency when mounted in horizontal piping with the main valve cover up. We recommend isolation valves be installed on inlet and outlet for maintenance. Adequate space above and around the valve for service personnel should be considered essential. A regular maintenance program should be established based on the specific application data. However, we recommend a thorough inspection be done at least once a year. Consult factory for specific recommendations.

Valve Size		Inches	1	1½	1½	2	2½	3	4	6	8	10	12	14	16	18	20	24	30	36
		mm.	25	32	40	50	65	80	100	150	200	250	300	350	400	450	500	600	750	900
C <sub>V</sub> Factor	Globe Pattern	Gal./Min. (gpm.)	14	14	14	25	37	52	90	218	362	660	810	1100	1200	1550	1950	3900	6100	9150
		Litres/Sec. (l/s.)	3.4	3.4	3.4	6.0	8.9	12.5	21.6	52	87	159	194	264	288	360	469	938	1466	2199
	Angle Pattern	Gal./Min. (gpm.)	15	15	15	26	39	55	95	232	388	479	790	1075	1175	—	—	3775	—	—
		Litres/Sec. (l/s.)	3.6	3.6	3.6	6.2	9.4	13.2	22.8	56	93	115	190	258	282	—	—	906	—	—
Equivalent Length of Pipe	Globe Pattern	Feet (ft.)	196	196	196	237	277	416	572	858	1315	2444	2118	1937	3022	3537	4199	4532	3897	3954
		Meters (m.)	60	60	60	72	84	127	174	262	401	745	646	590	921	1078	1280	1381	1188	1205
	Angle Pattern	Feet (ft.)	171	171	171	219	250	372	514	757	1145	2133	2226	2021	3152	—	—	2583	—	—
		Meters (m.)	52	52	52	67	76	113	157	231	349	650	678	616	961	—	—	787	—	—
K Factor	Globe Pattern	30.6	30.6	30.6	26.1	24.3	29.3	29.0	25.5	27.7	41.0	27.7	22.8	31.4	30.2	29.5	15.4	17.6	15.1	
	Angle Pattern	26.7	26.7	26.7	24.1	21.8	26.2	26.0	22.5	24.1	35.8	29.1	23.8	32.8	—	—	16.4	—	—	
Liquid Displaced from Cover Chamber When Valve Opens	U.S. Gal.	0.2	0.2	0.2	.03	.04	.08	.17	.53	1.26	2.5	4.0	6.5	9.6	11	12	29	65	90	
	Litres	0.8	0.8	0.8	.12	.16	.30	.64	2.0	4.8	9.5	15.1	25.6	36.2	41.6	45.4	110	246	340	

For assistance in selecting appropriate valve options or valves manufactured with special design requirements, please contact our Regional Sales Office or Factory.

**C<sub>V</sub> Factor**

Formulas for computing C<sub>V</sub> Factor, Flow (Q) and Pressure Drop (ΔP):

$$C_V = \frac{Q}{\sqrt{\Delta P}} \quad Q = C_V \sqrt{\Delta P} \quad \Delta P = \left(\frac{Q}{C_V}\right)^2$$

**K Factor (Resistance Coefficient)**

The Value of K is calculated from the formula:  $K = \frac{894d^4}{C_V^2}$  (U.S. system units)

**Equivalent Length of Pipe**

Equivalent lengths of pipe (L) are determined from the formula:  $L = \frac{Kd}{12f}$  (U.S. system units)

**Fluid Velocity**

Fluid velocity can be calculated from the following formula:  $V = \frac{.4085 Q}{d^2}$  (U.S. system units)

**Where:**

C<sub>V</sub> = U.S. (gpm) @ 1 psi differential at 60° F water  
or  
(l/s) @ 1 bar (14.5 PSIG) differential at 15° C water

d = inside pipe diameter of Schedule 40 Steel Pipe (inches)

f = friction factor for clean, new Schedule 40 pipe (dimensionless) (from Cameron Hydraulic Data, 18th Edition, P 3-119)

K = Resistance Coefficient (calculated)

L = Equivalent Length of Pipe (feet)

Q = Flow Rate in U.S. (gpm) or (l/s)

V = Fluid Velocity (feet per second) or (meters per second)

Δ P = Pressure Drop in (psi) or (bar)

100G-01KO ANTI-CAVITATION VALVE CURVES

SOLID LINE IS FULL OPEN FLOW CURVES FOR 18 FT/SEC CONTINUOUS DUTY APPLICATIONS  
DASHED LINE IS FULL OPEN FLOW CURVE FOR 25 FT/SEC INTERMITTENT DUTY APPLICATIONS

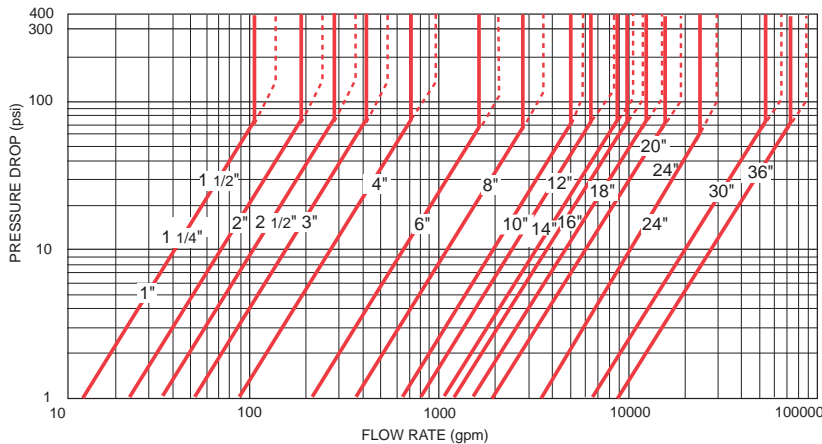

SELECTION GUIDELINE FOR KO ANTI-CAVITATION VALVES

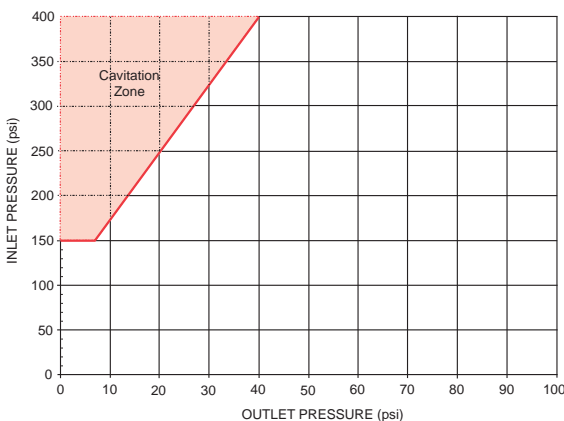

**Notes: On Operating Differential**

1. For atmospheric discharge, the maximum inlet pressure cannot exceed 150 psi.
2. For pressure differentials greater than 300 psi the maximum flow velocity should not exceed 18 ft/sec.
3. Flow velocities greater than 25 ft/sec are not recommended.
4. Recommended minimum flow velocity is 1 ft/sec.
5. Consult factory for conditions exceeding these recommendations.

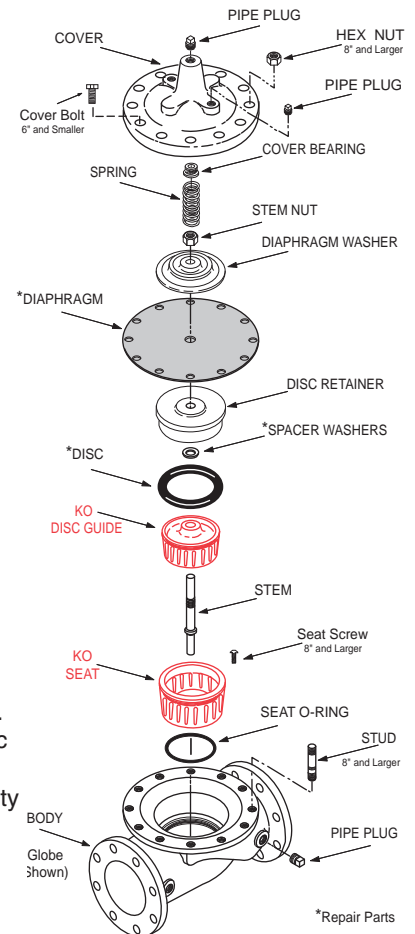

## 100-01KO Hytrol Main Valve with Anti-Cavitation Trim Purchase Specifications

### Function

The valve shall be hydraulically operated, single diaphragm actuated, globe pattern. The valve shall consist of three major components: the body with seat installed, the cover with bearing installed, and the diaphragm assembly. The diaphragm assembly shall be the only moving part and shall form a sealed chamber in the upper portion of the valve, separating operating pressure from line pressure. Packing glands and/or stuffing boxes are not permitted and there shall be no pistons operating the main valve or pilot controls. Ductile Iron is standard, other materials shall be available. No fabrication or welding shall be used in the manufacturing process.

### Description

The anti-cavitation features of the seat and disc guide detail shall have flow slots equally spaced around their perimeters. The seat slots shall be orientated around the perimeter of the seat so that fluid entering the valve shall flow through the seat slot detail such that the fluid flow converges in the center chamber of the seat allowing potential cavitation to dissipate. The disc guide slots shall be positioned around the perimeter of the disc guide, configured and oriented in an angular direction so that fluid flow exiting through the slots is diverted away from direct impact into pressure boundary surfaces. Flow exiting the disc guide slots is directed in an angular path to increase the distance between the slot geometry and pressure boundary surfaces. If cavitation conditions exist, the increased distance between the slots and pressure boundary surfaces minimizes the potential for damage by allowing the cavitation bubbles to dissipate before they come in contact with pressure boundary surfaces. Anti-cavitation characteristics shall be controlled by the described slotted seat and disc guide components. The disc guide shall slide in the seat and allow controlled flow through the seat slots into the central seat chamber where flow shall continue from the seat chamber and exit through the angularly oriented slots of the disc guide. The seat and disc guide features used together shall provide anti-cavitation characteristics suitable for applications where a large controlled pressure drop is desired.

The flexible, non-wicking, FDA approved diaphragm shall consist of nylon fabric bonded with synthetic rubber compatible with the operating fluid. The diaphragm must withstand a Mullins burst test of a minimum of 600 psi per layer of nylon fabric and shall be cycle tested 100,000 times to insure longevity. The diaphragm shall be fully supported in the valve body and cover by machined surfaces which support no less than one-half of the total surface area of the diaphragm in either the fully open or fully closed position.

The valve seat in six inch and smaller size valves shall be threaded into the body. Valve seat in eight inch and larger size valves shall be retained by flat head machine screws for ease of maintenance. The seat shall be of the solid, one-piece design and shall have a minimum of a five degree taper on the seating surface for positive drip-tight shut-off. Pressed-in bearings and/or multi-piece seats shall not be permitted.

To insure proper alignment of the valve stem, the valve body and cover shall be machined with a locating lip. No "pinned" covers to the valve body shall be permitted. All necessary repairs and/or modifications other than replacement of the main valve body shall be possible without removing the valve from the pipeline.

The valve manufacturer shall warrant the valve to be free of defects in material and workmanship for a period of three years from date of shipment, provided the valve is installed and used in accordance with all applicable instructions. The valve manufacturer shall be able to supply a complete line of equipment from 1¼" through 48" sizes and a complete selection of complementary equipment.

### Material Specification

Valve Size:	Pressure Rating:
Main Valve Body and Cover:	Temperature Range:
Main Valve Trim:	Coating:
End Detail:	Desired Options:

### Application Information

Inlet/Outlet Pressures:  
Flow Rate:  
Pipe Diameter:  
Function (i.e. - Pressure Reducing, Pressure Relief, etc.):

This valve shall be a Cla-Val Model No. 100-01KO Hytrol Main Valve with Anti-Cavitation Trim as manufactured by Cla-Val, Newport Beach, CA

**Note:** Add this Hytrol Anti-Cavitation Trim Purchase Specification to main valve specification for control valves where there is a high potential for cavitation damage. Please contact our Regional Sales Offices or Factory for assistance.

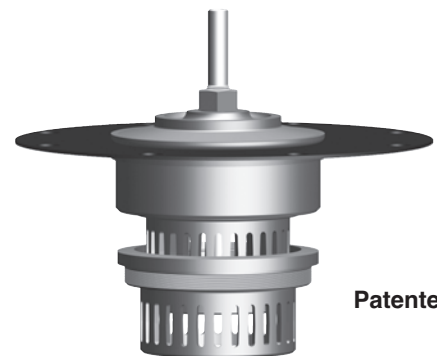

The Anti-Cavitation Trim components can be retrofitted to existing Hytrol valves if the application indicates an appropriate need. Please consult factory for details.



E-100-01KO (R-7/2015)

## CLA-VAL

1701 Placentia Avenue • Costa Mesa CA 92627

800-942-6326 • Fax: 949-548-5441 • Web Site: [cla-val.com](http://cla-val.com) • E-mail: [info@cla-val.com](mailto:info@cla-val.com)

**CLA-VAL CANADA**  
4687 Christie Drive  
Beamsville, Ontario  
Canada L0R 1B4  
Phone: 905-563-4963  
Fax: 905-563-4040  
E-mail [sales@cla-val.ca](mailto:sales@cla-val.ca)

**CLA-VAL EUROPE**  
Chemin des Mésanges 1  
CH-1032 Romanel/  
Lausanne, Switzerland  
Phone: 41-21-643-15-55  
Fax: 41-21-643-15-50  
E-mail: [cla-val@cla-val.ch](mailto:cla-val@cla-val.ch)

**CLA-VAL UK**  
Dainton House, Goods Station Road  
Tunbridge Wells  
Kent TN1 2 DH England  
Phone: 44-1892-514-400  
Fax: 44-1892-543-423  
E-mail: [info@cla-val.co.uk](mailto:info@cla-val.co.uk)

**CLA-VAL FRANCE**  
Porte du Grand Lyon 1  
ZAC du Champ du Périer  
France - 01700 Neyron  
Phone: 33-4-72-25-92-93  
Fax: 33-4-72-25-04-17  
E-mail: [cla-val@cla-val.fr](mailto:cla-val@cla-val.fr)

**CLA-VAL PACIFIC**  
45 Kennaway Road  
Woolston, Christchurch, 8023  
New Zealand  
Phone: 64-39644860  
[www.cla-valpacific.com](http://www.cla-valpacific.com)  
E-mail: [info@cla-valpacific.com](mailto:info@cla-valpacific.com)

©COPYRIGHT CLA-VAL 2018 Printed in USA Specifications subject to change without notice.

# 100-29S — MODEL —

600 Series

## Seawater Service Reduced Port Valve

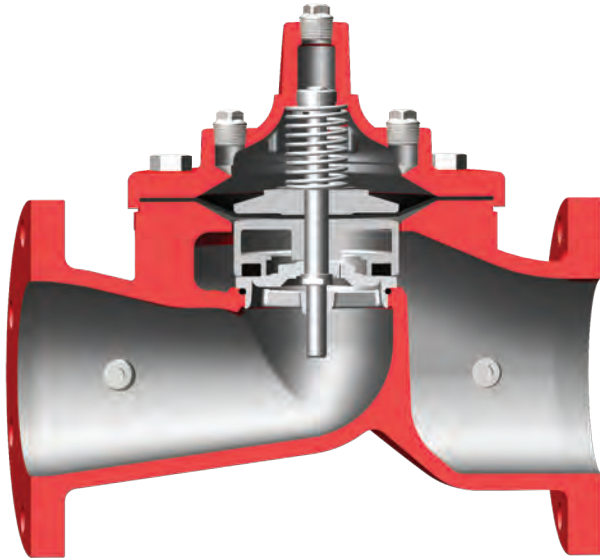

- **Reduced Cavitation Design**
- **Drip-Tight, Positive Seating Action**
- **Service Without Removal From Line**
- **Globe or Angle Pattern**
- **Every Valve Factory Tested**

The Cla-Val Model 100-29S Hytrol Valve is a hydraulically operated, diaphragm actuated, globe or angle pattern valve. It consists of three major components: body, diaphragm assembly and cover. The diaphragm assembly is the only moving part.

The diaphragm assembly is guided top and bottom by a precision machined stem which utilizes a non-wicking diaphragm of nylon fabric bonded with synthetic rubber. A resilient synthetic rubber disc, retained on three and one-half sides by a disc retainer, forms a drip-tight seal with the renewable seat when pressure is applied above the diaphragm.

The reduced cavitation characteristics of the 100-29S Hytrol Valve is the basis for the Cla-Val 600 Series. The rugged simplicity of design and packless construction assure a long life of dependable, trouble-free operation. It's smooth flow passages and fully guided disc and diaphragm assembly assure optimum control when used in piping systems requiring remote control, pressure regulation, solenoid operation, rate of flow control or check valve operation.

Available in various materials and in a wide range of sizes. It's applications are unlimited.

### Principle of Operation

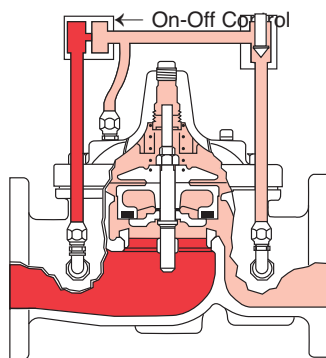

#### Full Open Operation

When pressure in the cover chamber is relieved to a zone of lower pressure, the line pressure at the valve inlet opens the valve, allowing full flow.

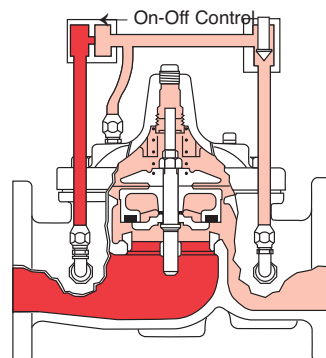

#### Tight Closing Operation

When pressure from the valve inlet is applied to the cover chamber, the valve closes drip-tight.

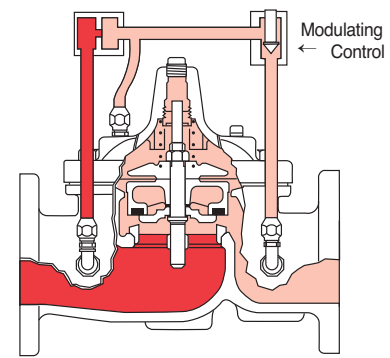

#### Modulating Action

The valve holds any intermediate position when operating pressure is equal above and below the diaphragm. Using a Cla-Val "Modulating" Control will allow the valve to automatically compensate for line pressure changes.

# Functional Data

# Model 100-29S

Valve Size		Inches	3	4	6	8	10	12	14	16	18	20	24	30	36	42	48
		mm.	80	100	150	200	250	300	350	400	460	500	600	750	900	1000	1200
$C_V$ Factor	Globe Pattern	Gal./Min. (gpm.)	62	136	229	480	930	1458	1725	2110	2940*	3400*	4020	7900*	11910*	14500*	15800*
		Litres/Sec. (l/s.)	15	32.5	55	115	223	350	414	506	705	816	966	1895	2858	3483	3796
	Angle Pattern	Gal./Min. (gpm.)	—	135	233	545	CF**	CF**	CF**	CF**	CF**	CF**	CF**	—	—	—	—
		Litres/Sec. (l/s.)	—	32	56	132	CF**	CF**	CF**	CF**	CF**	CF**	CF**	—	—	—	—
Equivalent Length of Pipe	Globe Pattern	Feet (ft.)	293	251	777	748	621	654	750	977	983	1125	3005	2130	2862	4232	7028
		Meters (m.)	89.3	76.4	237.1	228.1	189.5	199.4	229	298	300	343	917	650	872	1290	2142
	Angle Pattern	Feet (ft.)	—	254	751	580	CF**	CF**	CF**	CF**	CF**	CF**	CF**	—	—	—	—
		Meters (m.)	—	77.6	229	176.9	CF**	CF**	CF**	CF**	CF**	CF**	CF**	—	—	—	—
K Factor	Globe Pattern	20.6	12.7	23.1	15.7	10.4	8.5	8.9	10.2	8.4	8.8	19.1	10.5	9.7	12.3	17.8	
	Angle Pattern	—	12.9	22.3	12.2	CF**	CF**	CF**	CF**	CF**	CF**	CF**	—	—	—	—	
Liquid Displaced from Cover Chamber When Valve Opens	Fl. Oz	—	—	—	—	—	—	—	—	—	—	—	—	—	—	—	
	U.S. Gal.	0.32	.08	.17	.53	1.26	2.51	4.0	4.0	9.6	9.6	9.6	29.0	42	90	90	
	ml	—	—	—	—	—	—	—	—	—	—	—	—	—	—	—	
	Litres	.12	.30	.64	2.0	4.8	9.5	15.1	15.1	36.2	36.2	36.2	110	197	340	340	

\*\*Consult Factory

\*Estimated

### $C_V$ Factor

Formulas for computing  $C_V$  Factor, Flow (Q) and Pressure Drop ( $\Delta P$ ):

$$C_V = \frac{Q}{\sqrt{\Delta P}} \quad Q = C_V \sqrt{\Delta P} \quad \Delta P = \left( \frac{Q}{C_V} \right)^2$$

### K Factor (Resistance Coefficient)

The Value of K is calculated from the formula:  $K = \frac{894d^4}{C_V^2}$  (U.S. system units)

### Equivalent Length of Pipe

Equivalent lengths of pipe (L) are determined from the formula:  $L = \frac{Kd}{12f}$  (U.S. system units)

### Fluid Velocity

Fluid velocity can be calculated from the following formula:  $V = \frac{.4085 Q}{d^2}$  (U.S. system units)

### Where:

$C_V$  = U.S. (gpm) @ 1 psi differential at 60° F water  
or  
= (l/s) @ 1 bar (14.5 PSIG) differential at 15° C water

d = inside pipe diameter of Schedule 40 Steel Pipe (inches)

f = friction factor for clean, new Schedule 40 pipe (dimensionless) (from Cameron Hydraulic Data, 18th Edition, P 3-119)

K = Resistance Coefficient (calculated)

L = Equivalent Length of Pipe (feet)

Q = Flow Rate in U.S. (gpm) or (l/s)

V = Fluid Velocity (feet per second) or (meters per second)

$\Delta P$  = Pressure Drop in (psi) or (bar)

## Model 100-29S Flow Chart (Based on normal flow through a wide open valve)

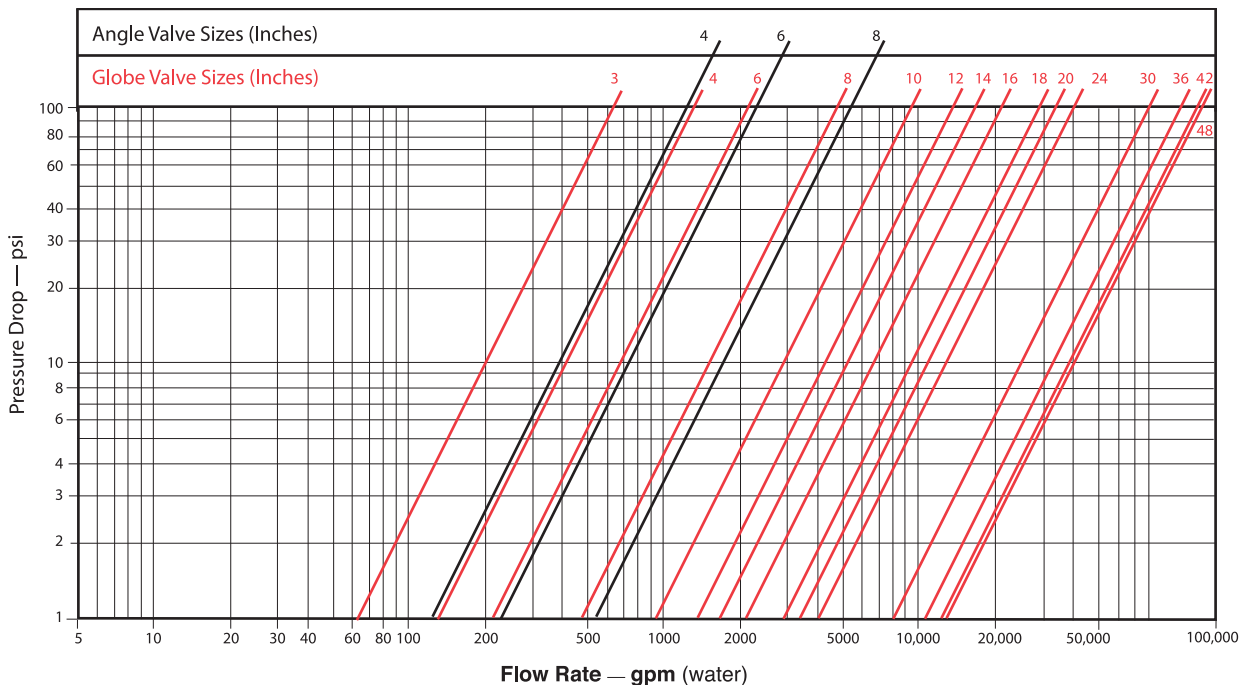

## Specifications

Model 100-29S

### Available Sizes

Pattern	Flanged
Globe	3",4",6",8",10",12",16",18",20",24",30",36", 42", 48"
Angle	4",6",8"

### Operating Temp. Range

Fluids
-40° to 180° F

### Pressure Ratings (Recommended Maximum Pressure - psi)

Valve Body & Cover		Pressure Class			
		Flanged		Threaded	
Material	Material Specifications	ANSI Standards**	150 Class	300† Class	End‡ Details
Ductile Iron*	ASTM-A536	B16.42	250	640	400
Cast Steel*	ASTM A216	B16.5	285	740	400
Naval Bronze	ASTM B61	B16.24	225	500	400
Stainless Steel Type 316	ASTM A743-CF-8M	B16.5	285	720	400
Ni.AL.Bronze	ASTM B148	B.16.24	225	500	400
Super Duplex Stainless Steel		B16.5	285	720	400

Note: \* Fusion Bonded Epoxy Coated Internal and External.  
 \*\* ANSI standards are for flange dimensions only.  
 Flanged valves are available faced but not drilled.  
 ‡ End Details machined to ANSI B2.1 specifications.  
 † Consult factory when Maximum Operating Pressure Differential (MOPD) is greater than 400 PSID



3" Globe, Flanged

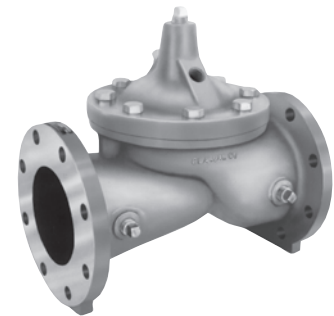

6" Globe, Flanged

## Materials

Component	Standard Material Combinations					
Body & Cover	Ductile Iron	Cast Steel	Bronze	Stainless Steel Type 316	Ni. AL. Bronze	Super Duplex Stainless Steel
Available Sizes	1¼" - 48"	1¼" - 16"	1¼" -16"	1¼" -16"	1¼" -16"	1¼" -16"
Disc Retainer & Diaphragm Washer	Cast Iron	Cast Steel	Bronze	Bronze	Ni. AL. Bronze	Super Duplex Stainless Steel
Trim: Disc Guide, Seat & Cover Bearing	Bronze is Standard Stainless Steel is optional					
Disc	Buna-N® Rubber					
Diaphragm	Nylon Reinforced Buna-N® Rubber					
Stem, Nut & Spring	Stainless Steel					

For material options not listed, consult factory.  
 Cla-Val manufactures valves in more than 50 different alloys.



6" Angle, Flanged

## Options

### Epoxy Coating - suffix KC

An FDA approved fusion bonded epoxy coating for use with cast iron, ductile iron or steel valves. This coating is resistant to various water conditions, certain acids, chemicals, solvents and alkalies. Epoxy coatings are applied in accordance with AWWA coating specifications C116-03. Do not use with temperatures above 175° F.

### Water Treatment Clearance - suffix KW

This additional clearance is beneficial in applications where water treatment compounds can interfere with the closing of the valve. The smaller outside diameter disc guide provides more clearance between the disc guide and the valve seat. This option is best suited for valves used in on-off (non-modulating) service.

### Viton® Rubber Parts - suffix KB

Optional diaphragm, disc and o-ring fabricated with Viton® synthetic rubber. Viton® is well suited for use with mineral acids, salt solutions, chlorinated hydrocarbons, and petroleum oils; and is primarily used in high temperature applications up to 250° F. Do not use with epoxy coatings above 175° F.

### Heavy Spring - suffix KH

The heavy spring option is used in applications where there is low differential pressure across the valve, and the additional spring force is needed to help the valve close. This option is best suited for valves used in on-off (non-modulating) service.

### Low Temperature Diaphragm - suffix KA

This single ply diaphragm uses Buna-N® Synthetic Rubber, formulated for low temperature applications to -65° F. Operating pressures in excess of 125 psi are not recommended.

For assistance in selecting appropriate valve options or valves manufactured with special design requirements, please contact our Regional Sales Office or Factory.

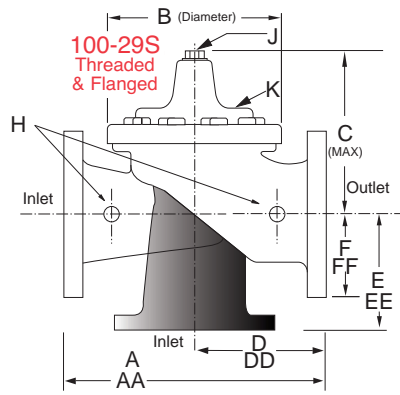

### Dimensions

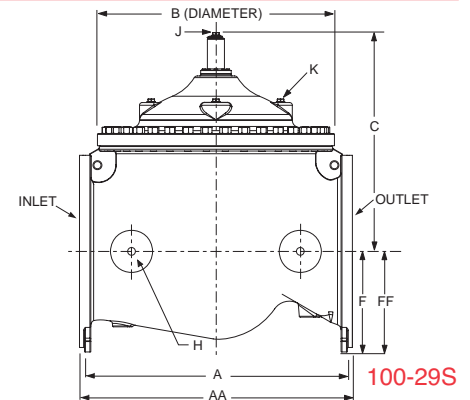
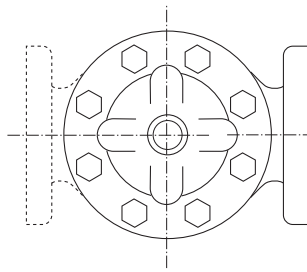

Valve Size (Inches)	3	4	6	8	10	12	14	16	18	20	24	30	36	42	48
A 150 ANSI	10.25	13.88	17.75	21.38	26.00	30.00	34.25	35.00	42.12	48.00	48.00	63.25	65.00	76.00	94.50
AA 300 ANSI	11.00	14.50	18.62	22.38	27.38	31.50	35.75	36.62	43.63	49.62	49.75	63.75	67.00	76.00	94.50
B Dia.	6.62	9.12	11.50	15.75	20.00	23.62	27.47	28.00	35.44	35.44	35.44	53.19	56.00	66.00	66.00
C Max.	7.00	8.62	11.62	15.00	17.88	21.00	20.88	25.75	25.00	31.50	31.50	43.94	54.60	61.50	61.50
D 150 ANSI	—	6.94	8.88	10.69	CF*	CF*	CF*	CF*	CF*	CF*	CF*	—	—	—	—
DD 300 ANSI	—	7.25	9.38	11.19	CF*	CF*	CF*	CF*	CF*	CF*	CF*	—	—	—	—
E 150 ANSI	—	5.50	6.75	7.25	CF*	CF*	CF*	CF*	CF*	CF*	CF*	—	—	—	—
EE 300 ANSI	—	5.81	7.25	7.75	CF*	CF*	CF*	CF*	CF*	CF*	CF*	—	—	—	—
F 150 ANSI	3.75	4.50	5.50	6.75	8.00	9.50	11.00	11.75	15.88	14.56	17.00	19.88	25.50	28.00	31.50
FF 300 ANSI	4.12	5.00	6.25	7.50	8.75	10.25	—	12.75	15.88	16.06	19.00	22.00	27.50	28.00	31.50
H NPT Body Tapping	.375	.50	.75	.75	1	1	1	1	1	1	1	1	2	2	2
J NPT Cover Center Plug	.50	.50	.75	.75	1	1	1.25	1.25	2	2	2	2	2	2	2
K NPT Cover Tapping	.375	.50	.75	.75	1	1	1	1	1	1	1	1	2	2	2
Valve Stem Internal Thread UNF	10-32	¼-28	¼-28	¾-24	¾-24	¾-24	¾-24	¾-24	½-20	½-20	½-20	¾-16	¾-16	M20	M20
Stem Travel	0.6	0.8	1.1	1.7	2.3	2.8	3.4	3.4	4.5	4.5	4.5	6.5	7.5	8.5	8.5
Approx. Ship Wt. Lbs.	45	85	195	330	625	900	1250	1380	1500	2551	2733	6500	8545	12450	13100

\*Consult Factory

Note: The top two flange holes on valve sizes 36 thru 48 are threaded to 1 1/2"-6 UNC.

Valve Size (mm)	80	100	150	200	250	300	350	400	450	500	600	750	900	1000	1200
A 150 ANSI	260	353	451	543	660	762	870	889	1070	1219	1219	1607	1651	1930	2400
AA 300 ANSI	279	368	473	568	695	800	908	930	1108	1260	1263	1619	1702	1930	2400
B Dia.	168	232	292	400	508	600	698	711	900	900	900	1351	1422	1676	1676
C Max.	178	219	295	381	454	533	530	654	635	800	800	1116	1387	1562	1562
D 150 ANSI	—	176	226	272	CF*	CF*	CF*	CF*	CF*	CF*	CF*	—	—	—	—
DD 300 ANSI	—	184	238	284	CF*	CF*	CF*	CF*	CF*	CF*	CF*	—	—	—	—
E 150 ANSI	—	140	171	184	CF*	CF*	CF*	CF*	CF*	CF*	CF*	—	—	—	—
EE 300 ANSI	—	148	184	197	CF*	CF*	CF*	CF*	CF*	CF*	CF*	—	—	—	—
F 150 ANSI	95	114	140	171	203	241	279	298	403	370	432	505	648	711	800
FF 300 ANSI	105	127	159	191	222	260	—	324	403	408	483	559	699	711	800
H NPT Body Tapping	.375	.50	.75	.75	1	1	1	1	1	1	1	1	2	2	2
J NPT Cover Center Plug	.50	.50	.75	.75	1	1	1.25	1.25	2	2	2	2	2	2	2
K NPT Cover Tapping	.375	.50	.75	.75	1	1	1	1	1	1	1	1	2	2	2
Valve Stem Internal Thread UNF	10-32	¼-28	¼-28	¾-24	¾-24	¾-24	¾-24	¾-24	½-20	½-20	½-20	¾-16	¾-16	M20	M20
Stem Travel	15	20	28	43	58	71	86	86	86	114	114	165	191	216	216
Approx. Ship Wt. Kgs.	20	39	89	150	284	409	568	627	681	1157	1249	2951	3876	5647	5942

For assistance in selecting appropriate valve options or valves manufactured with special design requirements, please contact our Regional Sales Office or Factory.

### Service and Installation

Cla-Val Control Valves operate with maximum efficiency when mounted in horizontal piping with the main valve cover UP, however, other positions are acceptable. Due to component size and weight of 10 inch and larger valves, installation with cover UP is advisable. We recommend isolation valves be installed on inlet and outlet for maintenance. Adequate space above and around the valve for service personnel should be considered essential. A regular maintenance program should be established based on the specific application data. However, we recommend a thorough inspection be done at least once a year. Consult factory for specific recommendations.



E-100-29S (R-11/2012)

### CLA-VAL

1701 Placentia Avenue • Costa Mesa CA 92627

800-942-6326 • Fax: 949-548-5441 • Web Site: cla-val.com • E-mail: info@cla-val.com

#### CLA-VAL CANADA

4687 Christie Drive  
Beamsville, Ontario  
Canada L0R 1B4  
Phone: 905-563-4963  
Fax: 905-563-4040  
E-mail sales@cla-val.ca

#### CLA-VAL EUROPE

Chemin des Mésanges 1  
CH-1032 Romanel/  
Lausanne, Switzerland  
Phone: 41-21-643-15-55  
Fax: 41-21-643-15-50  
E-mail: cla-val@cla-val.ch

#### CLA-VAL UK

Dainton House, Goods Station Road  
Tunbridge Wells  
Kent TN11 2 DH England  
Phone: 44-1892-514-400  
Fax: 44-1892-543-423  
E-mail: info@cla-val.co.uk

#### CLA-VAL FRANCE

Porte du Grand Lyon 1  
ZAC du Champ du Pérrier  
France - 01700 Neyron  
Phone: 33-4-72-25-92-93  
Fax: 33-4-72-25-04-17  
E-mail: cla-val@cla-val.fr

#### CLA-VAL PACIFIC

45 Kennaway Road  
Woolston, Christchurch, 8023  
New Zealand  
Phone: 64-39644860  
www.cla-valpacific.com  
E-mail: info@cla-valpacific.com

# 800GS — MODEL —

## 800 Series (Tubular Diaphragm Valve)



### Deluge Valve

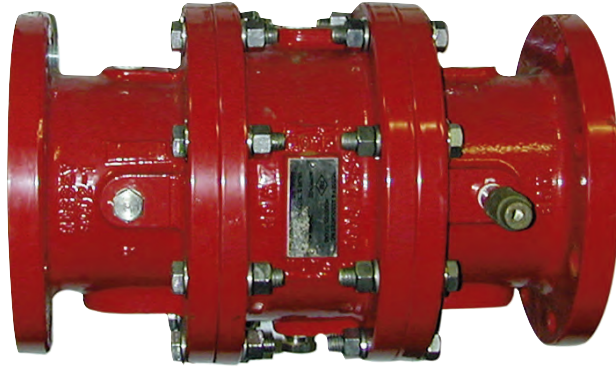

- Low Head Loss
- Cast Steel Construction
- Stainless Steel Pilot and Tubing
- Stainless Steel Solenoid
- Anti-Cavitation Design
- Fusion Coated Epoxy Inside and Out
- Nickel Aluminum Bronze Construction Option (ASTM B148)
- Super Duplex Stainless Steel Construction Option (ASTM A890 GR5A)
- Low Maintenance
- Simple and Reliable Operation
- 1-Year Warranty



The Cla-Val Model 800GS Deluge Valve is a pressure operated, in-line axial valve. A tube diaphragm actuates the valve, which is comprised of three major components: 1) Tube 2) Barrier and 3) Body. There is only one moving part in the valve - the tube diaphragm. There are no shafts, packing, stem guides or springs.

The tube diaphragm is a one piece, homogeneous nitrile rubber part which is extremely durable. The ends of the tube are thick solid rubber, designed to fit between mating flanges. This design eliminates the possibility of cutting the tube diaphragm due to over tightening or piping misalignment during installation.

The tube forms a drip tight seal around the barrier when the pressure is equalized between the valve inlet and the control chamber. When pressure is removed from the control chamber, the valve is open. The minimum recommended operating pressure is 40 P.S.I. of inlet pressure.

**The 800GS is manufactured in materials suitable for seawater and freshwater service.**

### Principle of Operation

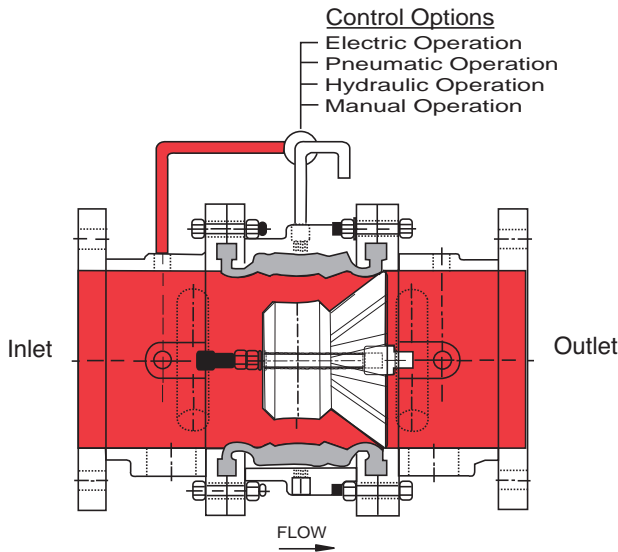

**Full Open Operation**

When pressure in control chamber is relieved, the valve is open.

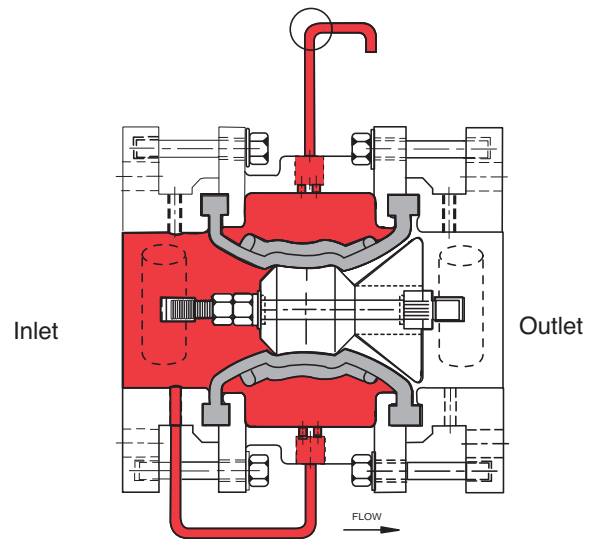

**Tight Closing Operation**

Water pressure from valve inlet is applied to the control chamber. Valve closes bubble tight.

## Dimensions

## Model 800GS

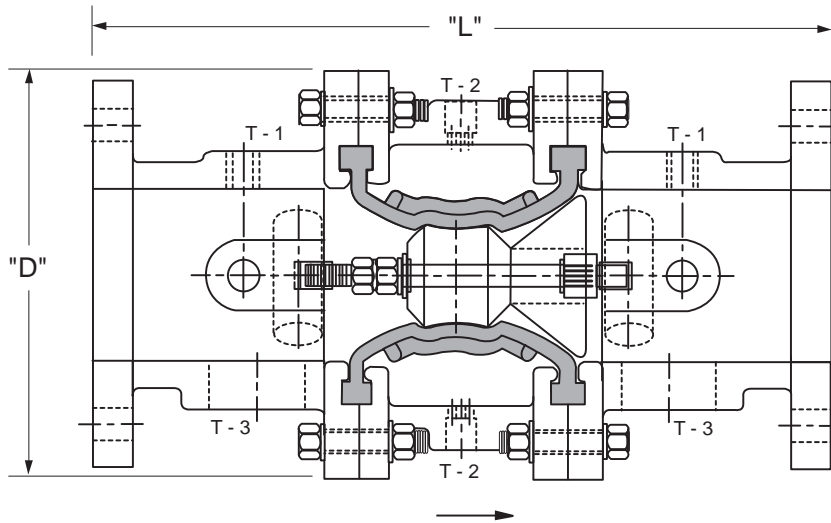

Valve Size (Inches)	4	6	8	10
L	17.25	18.25	20.00	22.00
D	9.5	11.75	14.00	16.00
T-1/T-2 (NPT)	1/2	1/2	1/2	1/2
T-3 (NPT)	2	2	2	2
Approx. Wt. (Lbs.)	151	196	285	330

Valve Size (mm)	100	150	200	250
L	438	464	508	559
D	241	299	356	406
T-1/T-2 (NPT)	1/2	1/2	1/2	1/2
T-3 (NPT)	2	2	2	2
Approx. Wt. (kgs)	68	89	129	150

4", 6", 8" and 10" Factory Mutual Components

FLOW FACTORS		
SIZE (IN)	CV (gpm)	KV
4"	340	77.3
6"	885	201
8"	1667	379
*10"	2424	550

\*Calculated

### MAIN VALVE

Ends:	Flanged ANSI B16.5 (150lb Class)
Body:	Cast Steel (ASTM A216 WCB)
Tube Diaphragm:	Nitrile Rubber
Barrier:	Urethane
Bolts:	316 SS
Pressure:	250 psig (17.24 BAR)
Temp. Range:	32° F to 180° F (0° C to 82.2° C)

### MAIN VALVE OPTIONS

Body:	Nickel Aluminum Bronze (ASTM B148) or Super Duplex SS (ASTM A890 GR5A)
-------	--

### PILOT VALVE

All Parts:	316 SS
O-Rings:	Nitrile Rubber
Control Range:	20 to 250 PSIG
Pilot Pressure Range:	20 to 250 PSIG
Operation:	Latches in operated position; manual reset

### PILOT VALVE OPTIONS

All Parts:	Monel (Alloy 400)
Operation:	Non-latching

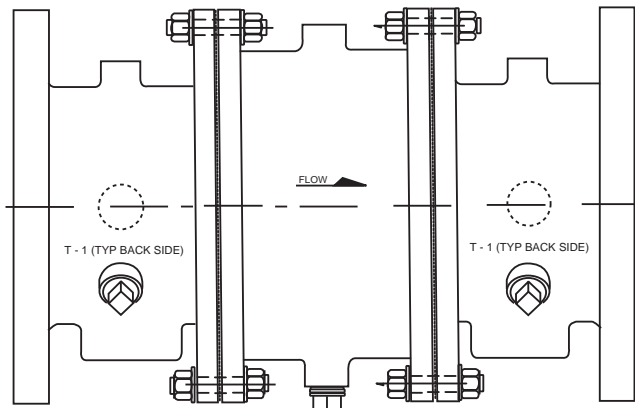

### When Ordering Please Specify:

- Catalog No. 800GS
- Valve Size
- Fluid Being Handled
- Fluid Temperature Range
- Inlet Pressure Range
- Outlet Pressure Range
- Maximum Differential Pressure
- Minimum Differential Pressure
- Maximum Flow Rate

Cla-Val 800 Series Control Valves operate with maximum efficiency when mounted in horizontal or vertical piping. We recommend isolation valves be installed on inlet and outlet for maintenance. Adequate space above and around the valve for service personnel should be considered essential. A regular maintenance program should be established based on the specific application data. However, we recommend a thorough inspection be done at least once a year. Consult factory for specific recommendations.



E-800GS (R-03/2015)

## CLA-VAL

1701 Placentia Avenue • Costa Mesa CA 92627

800-942-6326 • Fax: 949-548-5441 • Web Site: [cla-val.com](http://cla-val.com) • E-mail: [info@cla-val.com](mailto:info@cla-val.com)

#### CLA-VAL CANADA

4687 Christie Drive  
Beamsville, Ontario  
Canada L0R 1B4  
Phone: 905-563-4963  
Fax: 905-563-4040  
E-mail: [sales@cla-val.ca](mailto:sales@cla-val.ca)

#### CLA-VAL EUROPE

Chemin des Mésanges 1  
CH-1032 Romanel/  
Lausanne, Switzerland  
Phone: 41-21-643-15-55  
Fax: 41-21-643-15-50  
E-mail: [cla-val@cla-val.ch](mailto:cla-val@cla-val.ch)

#### CLA-VAL UK

Dainton House, Goods Station Road  
Tunbridge Wells  
Kent TN11 2 DH England  
Phone: 44-1892-514-400  
Fax: 44-1892-543-423  
E-mail: [info@cla-val.co.uk](mailto:info@cla-val.co.uk)

#### CLA-VAL FRANCE

Porte du Grand Lyon 1  
ZAC du Champ du Pérrier  
France - 01700 Neyron  
Phone: 33-4-72-25-92-93  
Fax: 33-4-72-25-04-17  
E-mail: [cla-val@cla-val.fr](mailto:cla-val@cla-val.fr)

#### CLA-VAL PACIFIC

45 Kennaway Road  
Woolston, Christchurch, 8023  
New Zealand  
Phone: 64-39644860  
[www.cla-valpacific.com](http://www.cla-valpacific.com)  
E-mail: [info@cla-valpacific.com](mailto:info@cla-valpacific.com)

©COPYRIGHT CLA-VAL 2018 Printed in USA. Specifications subject to change without notice.

# 100-43 — MODEL —

## 800 Series



# Tubular Diaphragm Valve



- Low Head Loss
- Cast Steel Construction
- Fusion Coated Epoxy Inside and Out
- Anti-Cavitation Design
- Nickel Aluminum Bronze Construction Option (Alloy C95800)
- Duplex Stainless Steel Construction Option (Alloy 2205)
- Low Maintenance
- Simple and Reliable Operation
- 1-Year Warranty

The Cla-Val Model 100-43 Tubular Diaphragm Valve is a pressure-operated, in-line axial valve. A tube diaphragm actuates the valve, which is comprised of three major components: 1) Tube 2) Barrier and 3) Body. There is only one moving part in the valve — the tube diaphragm. There are no shafts, packing, stem guides or springs.

The tube diaphragm is a one piece, homogeneous nitrile rubber part which is extremely durable. The ends of the tube are thick solid rubber, designed to fit between mating flanges. This design eliminates the possibility of cutting the tube diaphragm due to over tightening or piping misalignment during installation.

The tube forms a drip tight seal around the barrier when the pressure is equalized between the valve inlet and the control chamber. When pressure is removed from the control chamber, the valve is open. The minimum recommended operating pressure is 40 P.S.I. of inlet pressure.

## Principle of Operation

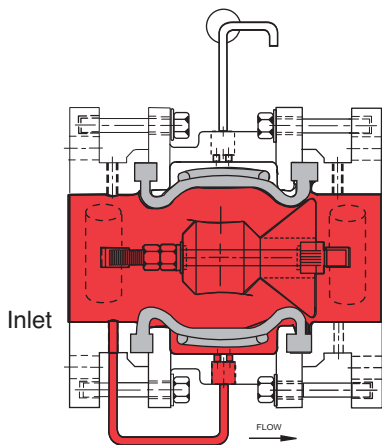

### Full Open Operation

The valve opens when pilot set pressure is reached and pressure in the control chamber is relieved.

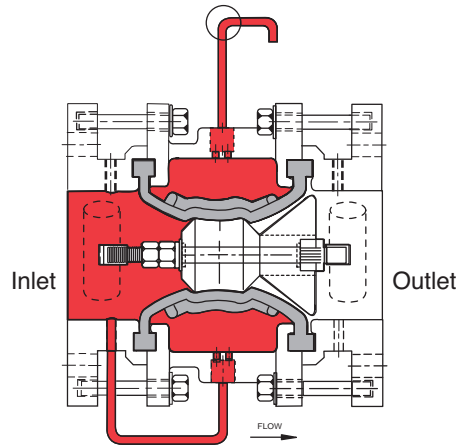

### Tight Closing Operation

Water pressure (equal to inlet pressure) from valve inlet or from upstream of valve is applied to the control chamber. Valve closes bubble tight.

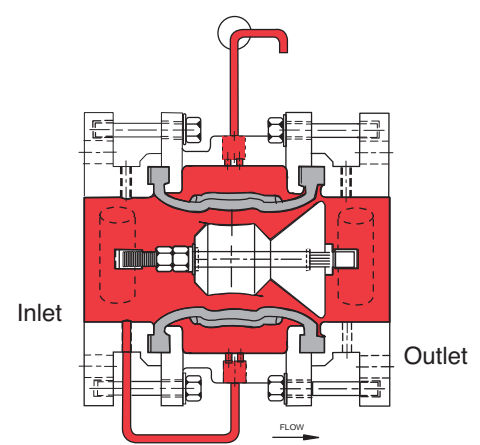

### Modulating Action

The valve tube diaphragm holds any intermediate position when a quantity of water is exhausted from the control chamber via the pilot. The quantity of water in the control chamber is established by the “set pressure” of the pilot.

The control chamber is filled or exhausted to atmosphere, maintaining “set pressure.”

## MAIN VALVE

Ends: Flanged ANSI B16.5 (150lb Class)  
 Body: Cast Steel (ASTM A216 WCB)  
 Tube Diaphragm: Nitrile Rubber  
 Barrier: Urethane  
 Bolts: 316 SS  
 Pressure: 250 psig (17.24 BAR)  
 Temp. Range: 32° F to 180° F  
 (0° C to 82.2° C)

## MAIN VALVE OPTIONS

Body: Nickel Aluminum Bronze  
 (Alloy C95800) or  
 Duplex SS (Alloy 2205)

**Model 100-43**



**Note:** For valve pilot assembly, only use the X43 "Y" Strainer,  
**NOT** the X46A Flow Clean Strainer

## Dimensions

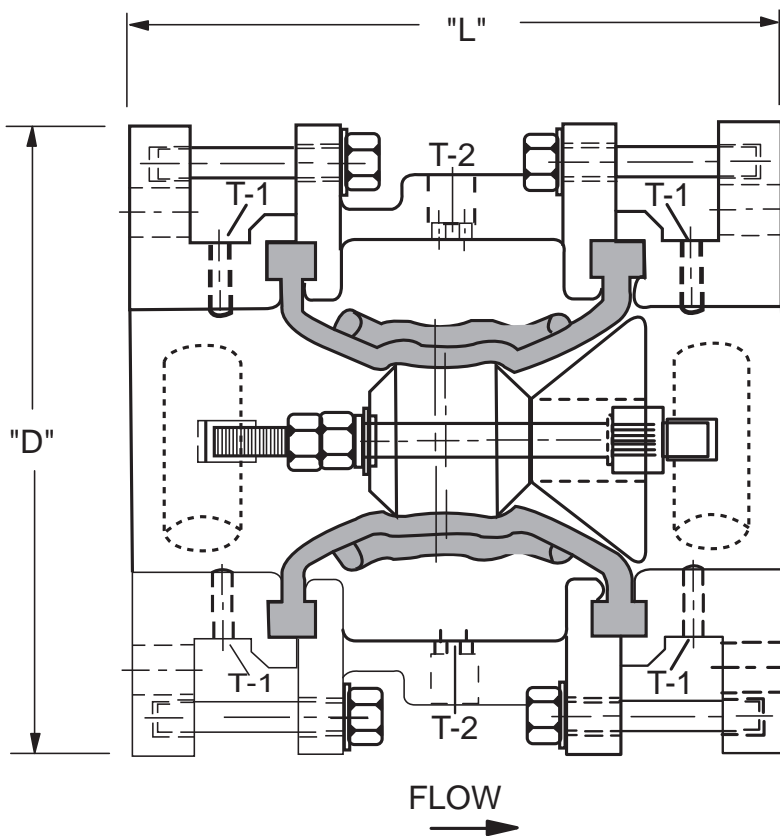

Valve Size (Inches)	3	4	6	8	10
L	8.75	9.75	10.75	11.75	14.00
D	7.5	9.5	11.75	14.00	16.44
T-1 (NPT)	1/4	1/4	1/4	3/8	1/2
T-2 (NPT)	1/4	1/2	1/2	1/2	1/2
Approx. Wt. (Lbs.)	67	99	135	185	270

Valve Size (mm)	80	100	150	200	200
L	222	248	273	299	299
D	191	241	299	356	356
T-1 (NPT)	1/4	1/4	1/4	3/8	1/2
T-2 (NPT)	1/4	1/2	1/2	1/2	1/2
Approx. Wt. (kgs.)	30	45	61	84	123

4", 6", 8" Factory Mutual Approved  
 (with approved Pilot Components)

FLOW FACTORS		
SIZE (IN)	CV (gpm)	KV
3"	160	36.4
4"	340	77.3
6"	885	201
8"	1667	379
*10"	2424	550

\* Calculated

## When Ordering Please Specify:

1. Catalog No. 100-43
2. Valve Size
3. Fluid Being Handled
4. Fluid Temperature Range
5. Inlet Pressure Range
6. Outlet Pressure Range
7. Maximum Differential Pressure
8. Minimum Differential Pressure
9. Maximum Flow Rate



E-100-43 (R-09/2016)

## CLA-VAL

1701 Placentia Avenue • Costa Mesa CA 92627  
 800-942-6326 • Fax: 949-548-5441 • Web Site: cla-val.com • E-mail: info@cla-val.com

### CLA-VAL CANADA

4687 Christie Drive  
 Beamsville, Ontario  
 Canada L0R 1B4  
 Phone: 905-563-4963  
 Fax: 905-563-4040  
 E-mail sales@cla-val.ca

### CLA-VAL EUROPE

Chemin des Mésanges 1  
 CH-1032 Romanel/  
 Lausanne, Switzerland  
 Phone: 41-21-643-15-55  
 Fax: 41-21-643-15-50  
 E-mail: cla-val@cla-val.ch

### CLA-VAL UK

Dainton House, Goods Station Road  
 Tunbridge Wells  
 Kent TN1 2 DH England  
 Phone: 44-1892-514-400  
 Fax: 44-1892-543-423  
 E-mail: info@cla-val.co.uk

### CLA-VAL FRANCE

Porte du Grand Lyon 1  
 ZAC du Champ du Pérrier  
 France - 01700 Neyron  
 Phone: 33-4-72-25-92-93  
 Fax: 33-4-72-25-04-17  
 E-mail: cla-val@cla-val.fr

### CLA-VAL PACIFIC

45 Kennaway Road  
 Woolston, Christchurch, 8023  
 New Zealand  
 Phone: 64-39644860  
 www.cla-valpacific.com  
 E-mail: info@cla-valpacific.com

# X43H — MODEL —



## Cla-Val Model X43H Strainer

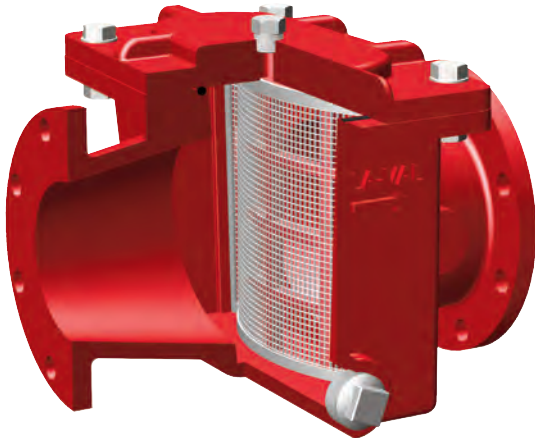

Now available up to 48-inches/1200 mm

- Low Pressure Drop
- Ductile Iron Fusion Bonded Epoxy Coated construction with a 316 Stainless Steel Strainer
- Also available: Nickel Aluminum Bronze Construction with a Titanium Strainer
- Large Flow Area H-Style Design
- Service Without Removal From Line

The durable Cla-Val Model X43HL H-Style Strainer is the easiest and most cost effective way to protect piping and equipment from damage caused by pipeline debris. Its large flow area and durable materials of construction means it can withstand the harsh conditions often encountered in refinery and offshore applications. The body port allows for installation of a manual flush valve to clear small amounts of debris from the strainer without removing the cover. For more thorough cleaning, the top cover can easily be removed without taking strainer out of the pipeline. The strainer may be installed in any position, however, installation with cover up is recommended

### Model X43HL Style Strainer Typical Application

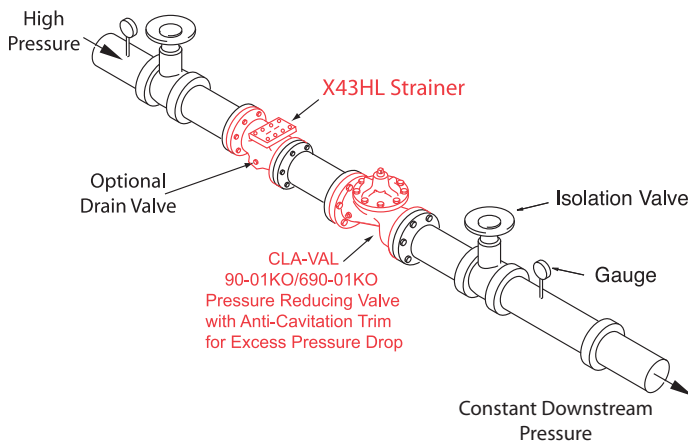

### Model X43HL Flow Chart

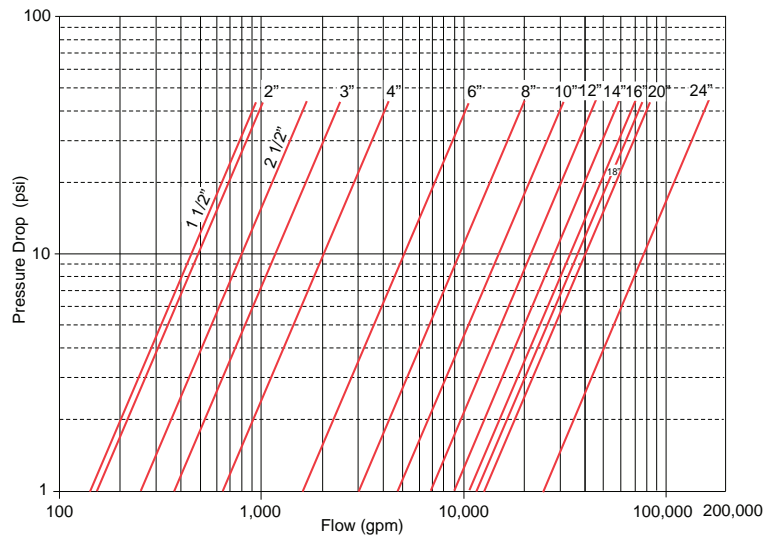

Please consult factory to confirm flow data for 36-inch/900 mm and 48-inch/1200 mm strainers

### C<sub>v</sub> Factor

Strainer Size (inches)	1 ½	2	2 ½	3	4	6	8	10	12	14	16	18	20	24
C <sub>v</sub> (Gal/Min. - gpm.)	96	150	254	367	654	1644	3922	4566	6800	8949	11692	12796	18264	26302
C <sub>v</sub> (Litres/Sec - l/s.)	23	36	61	85	157	395	702	1097	1580	2150	2809	3555	4388	6319

C<sub>v</sub> in gpm = gpm @ 1psid head loss • C<sub>v</sub> in l/s = l/s @ 1bar head loss

## Specifications

<b>Sizes (Inches):</b>	1½, 2, 2½, 3, 4, 6, 8, 10, 12, 14, 16, 18, 20, 24, 36 and 48
<b>Sizes (mm):</b>	40, 50, 65, 80, 100, 150, 200, 250, 300, 350, 400, 450, 500, 600, 900 and 1200
<b>Ends:</b>	Flanged, ANSI Class 150 and 300 ( <b>Note: 300# Flanges are Raised Face</b> )
<b>Max Pressure Rating:</b>	150 - 250 psi • 300 - 400 psi
<b>Fluids:</b>	Compatible with Materials of Construction
<b>Temperature:</b>	Maximum 180°F
<b>Materials:</b>	
<b>Body &amp; Cover:</b>	Ductile Iron ANSI B16.62; Fusion Bonded Epoxy Coating Standard or NiAlBrz ASTM B148
<b>Cover Seal:</b>	Buna-N® Synthetic Rubber
<b>Strainer:</b>	316 Stainless Steel; Ductile Iron, Epoxy Coated Frame or in Titanium on a NiAlBrz Frame
<b>Strainer Mesh Sizes:</b>	Standard 10 mesh / 2000 Micron / Openings 0.078 inch Optional .039 and .059 inch openings available
<b>Drain/Blow-Off Connection:</b>	Furnished with Plug as Standard.
<b>Bolts:</b>	SS 303 or Titanium

Please consult factory to confirm dimensional data for 36-inch/900 mm and 48-inch/1200 mm sizes

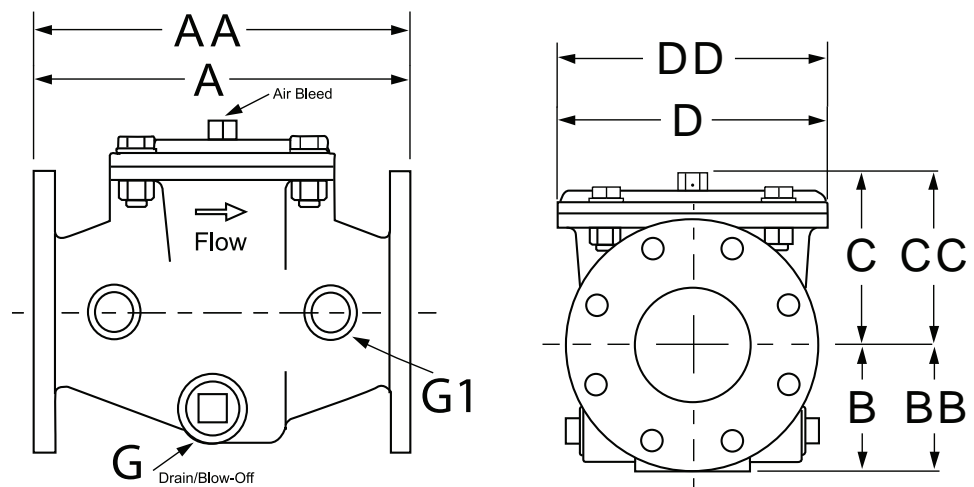

## Dimensions

Strainer Size (inches)	1 ½	2	2 ½	3	4	6	8	10	12	14	16	18	20	24
<b>A 150 ANSI</b>	9.06	9.06	9.06	11.81	11.81	15.75	19.69	22.83	24.02	25.59	31.50	31.50	37.40	43.31
<b>AA 300 ANSI</b>	9.13	9.13	9.13	11.89	11.89	15.83	19.76	22.91	24.09	25.67	31.57	31.57	37.48	43.39
<b>B 150 ANSI</b>	3.26	3.26	3.66	4.06	4.33	5.63	6.69	8.86	8.88	10.24	12.20	13.18	19.09	19.09
<b>BB 300 ANSI</b>	3.26	3.26	3.66	4.06	4.33	5.63	6.69	8.86	9.56	10.94	12.20	13.18	19.09	19.09
<b>C Max. 150 ANSI</b>	3.78	3.78	3.78	5.91	5.91	7.52	8.82	11.61	15.16	14.96	19.69	19.69	23.98	23.98
<b>CC Max. 300 ANSI</b>	5.20	5.20	5.35	6.22	6.22	7.99	9.33	12.79	15.67	15.67	19.69	19.69	23.98	23.98
<b>D Dia. 150 ANSI</b>	7.87	7.87	7.87	9.25	9.25	15.74	18.11	22.05	26.77	26.77	35.43	35.43	46.85	46.85
<b>DD Dia. 300 ANSI</b>	7.99	7.99	7.99	9.37	9.37	15.86	18.23	22.17	26.85	26.85	35.43	35.43	46.85	46.85
<b>G Drain/Blow-off Plug</b>	1¼	1¼	1¼	1¼	1¼	1¼	1¼	1¼	2	2	2	2	3	3
Approx. Ship Wt. Lbs.	33	36	39	59	73	143	212	432	626	683	970	1073	1175	1962

Strainer Size (mm)	40	50	65	80	100	150	200	250	300	350	400	450	500	600
<b>A 150 ANSI</b>	230	230	230	300	300	400	500	580	610	650	800	800	950	1100
<b>AA 300 ANSI</b>	232	232	232	302	302	402	502	582	612	652	802	802	952	1102
<b>B 150 ANSI</b>	83	83	93	103	110	143	170	225	228	260	310	335	485	485
<b>BB 300 ANSI</b>	83	83	93	103	110	143	170	225	243	278	310	335	485	486
<b>C Max. 150 ANSI</b>	96	96	96	150	150	191	224	295	385	380	500	500	609	609
<b>CC Max. 300 ANSI</b>	132	132	136	158	158	203	237	325	398	398	500	500	609	609
<b>D Dia. 150 ANSI</b>	200	200	200	235	235	400	460	560	680	680	900	900	1190	1190
<b>DD Dia. 300 ANSI</b>	203	203	203	238	238	403	463	563	682	682	900	900	1190	1190
<b>G Drain/Blow-off Plug</b>	1¼	1¼	1¼	1¼	1¼	1¼	1¼	1¼	2	2	2	2	3	3
Approx. Ship Wt. (kg)	15	16	18	27	33	65	96	196	284	310	440	600	810	890

# X43HL — MODEL —



## Cla-Val Model X43HL Strainer

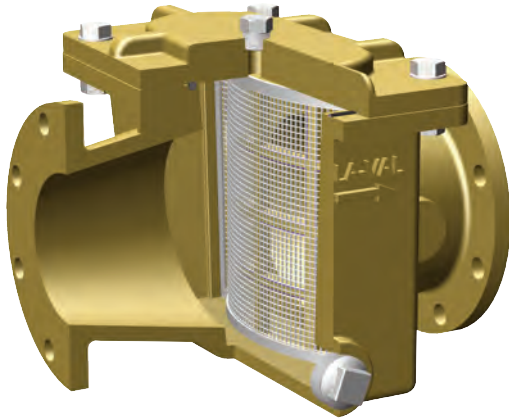

- Low Pressure Drop
- Ductile Iron Fusion Bonded Epoxy Coated construction with a 316 Stainless Steel Strainer
- Also available: Nickel Aluminum Bronze Construction with a Titanium Strainer
- Large Flow Area H-Style Design
- Service Without Removal From Line

The durable Cla-Val Model X43HL H-Style Strainer is the easiest and most cost effective way to protect piping and equipment from damage caused by pipeline debris. Its large flow area and durable materials of construction means it can withstand the harsh conditions often encountered in refinery and offshore applications. The body port allows for installation of a manual flush valve to clear small amounts of debris from the strainer without removing the cover. For more thorough cleaning, the top cover can easily be removed without taking strainer out of the pipeline. The strainer may be installed in any position, however, installation with cover up is recommended

### Model X43HL Style Strainer Typical Application

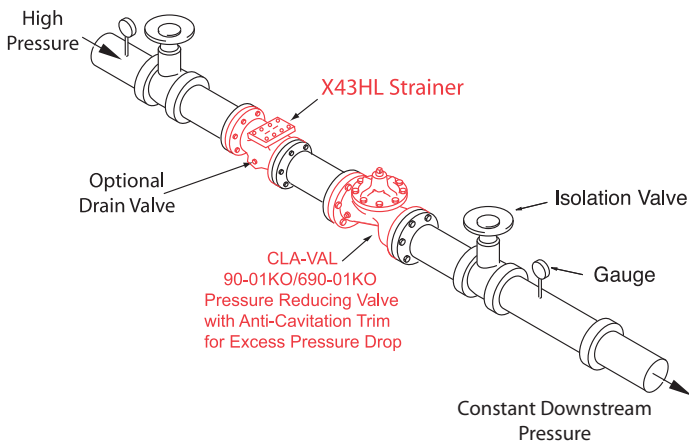

### Model X43HL Flow Chart

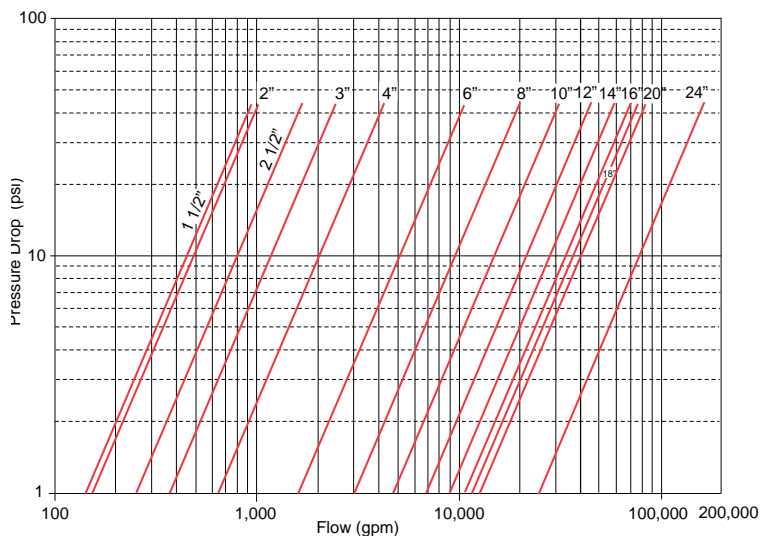

Please consult factory to confirm flow data  
for 36-inch/900 mm and 48-inch/1200 mm strainers

### C<sub>v</sub> Factor

Strainer Size (inches)	1 ½	2	2 ½	3	4	6	8	10	12	14	16	18	20	24
C <sub>v</sub> (Gal/Min. - gpm.)	96	150	254	367	654	1644	3922	4566	6800	8949	11692	12796	18264	26302
C <sub>v</sub> (Litres/Sec - l/s.)	23	36	61	85	157	395	702	1097	1580	2150	2809	3555	4388	6319

C<sub>v</sub> in gpm = gpm @ 1psid head loss • C<sub>v</sub> in l/s = l/s @ 1bar head loss

## Specifications

<b>Sizes (Inches):</b>	1½, 2, 2½, 3, 4, 6, 8, 10, 12, 14, 16, 18, 20, 24, 36 and 48
<b>Sizes (mm):</b>	40, 50, 65, 80, 100, 150, 200, 250, 300, 350, 400, 450, 500, 600, 900 and 1200
<b>Ends:</b>	Flanged, ANSI Class 150 and 300 ( <b>Note: 300# Flanges are Raised Face</b> )
<b>Max Pressure Rating:</b>	150 - 250 psi • 300 - 400 psi
<b>Fluids:</b>	Compatible with Materials of Construction
<b>Temperature:</b>	Maximum 180°F
<b>Materials:</b>	
<b>Body &amp; Cover:</b>	Ductile Iron ANSI B16.62; Fusion Bonded Epoxy Coating Standard or NiAlBrz ASTM B148
<b>Cover Seal:</b>	Buna-N® Synthetic Rubber
<b>Strainer:</b>	316 Stainless Steel; Ductile Iron, Epoxy Coated Frame or in Titanium on a NiAlBrz Frame
<b>Strainer Mesh Sizes:</b>	Standard 10 mesh / 2000 Micron / Openings 0.078 inch Optional .039 and .059 inch openings available
<b>Drain/Blow-Off Connection:</b>	Furnished with Plug as Standard.
<b>Bolts:</b>	SS 303 or Titanium

Please consult factory to confirm dimensional data for 36-inch/900mm strainers

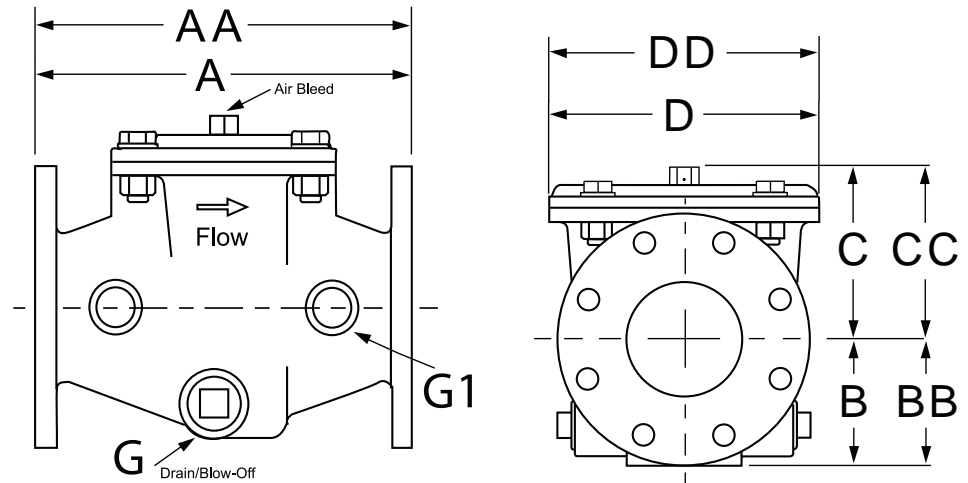

## Dimensions

Strainer Size (inches)	1 ½	2	2 ½	3	4	6	8	10	12	14	16	18	20	24
<b>A 150 ANSI</b>	9.06	9.06	9.06	11.81	11.81	15.75	19.69	22.83	24.02	25.59	31.50	31.50	37.40	43.31
<b>AA 300 ANSI</b>	9.13	9.13	9.13	11.89	11.89	15.83	19.76	22.91	24.09	25.67	31.57	31.57	37.48	43.39
<b>B 150 ANSI</b>	3.26	3.26	3.66	4.06	4.33	5.63	6.69	8.86	8.88	10.24	12.20	13.18	19.09	19.09
<b>BB 300 ANSI</b>	3.26	3.26	3.66	4.06	4.33	5.63	6.69	8.86	9.56	10.94	12.20	13.18	19.09	19.09
<b>C Max. 150 ANSI</b>	3.78	3.78	3.78	5.91	5.91	7.52	8.82	11.61	15.16	14.96	19.69	19.69	23.98	23.98
<b>CC Max. 300 ANSI</b>	5.20	5.20	5.35	6.22	6.22	7.99	9.33	12.79	15.67	15.67	19.69	19.69	23.98	23.98
<b>D Dia. 150 ANSI</b>	7.87	7.87	7.87	9.25	9.25	15.74	18.11	22.05	26.77	26.77	35.43	35.43	46.85	46.85
<b>DD Dia. 300 ANSI</b>	7.99	7.99	7.99	9.37	9.37	15.86	18.23	22.17	26.85	26.85	35.43	35.43	46.85	46.85
<b>G Drain/Blow-off Plug</b>	1¼	1¼	1¼	1¼	1¼	1¼	1¼	1¼	2	2	2	2	3	3
Approx. Ship Wt. Lbs.	33	36	39	59	73	143	212	432	626	683	970	1073	1175	1962

Strainer Size (mm)	40	50	65	80	100	150	200	250	300	350	400	450	500	600
<b>A 150 ANSI</b>	230	230	230	300	300	400	500	580	610	650	800	800	950	1100
<b>AA 300 ANSI</b>	232	232	232	302	302	402	502	582	612	652	802	802	952	1102
<b>B 150 ANSI</b>	83	83	93	103	110	143	170	225	228	260	310	335	485	485
<b>BB 300 ANSI</b>	83	83	93	103	110	143	170	225	243	278	310	335	485	486
<b>C Max. 150 ANSI</b>	96	96	96	150	150	191	224	295	385	380	500	500	609	609
<b>CC Max. 300 ANSI</b>	132	132	136	158	158	203	237	325	398	398	500	500	609	609
<b>D Dia. 150 ANSI</b>	200	200	200	235	235	400	460	560	680	680	900	900	1190	1190
<b>DD Dia. 300 ANSI</b>	203	203	203	238	238	403	463	563	682	682	900	900	1190	1190
<b>G Drain/Blow-off Plug</b>	1¼	1¼	1¼	1¼	1¼	1¼	1¼	1¼	2	2	2	2	3	3
Approx. Ship Wt. (kg)	15	16	18	27	33	65	96	196	284	310	440	600	810	890



# Solid Performer

## ***Cla-Val Model X43HL H-Style Strainer***

The durable Cla-Val Model X43HL H-Style Strainer is the easiest and most cost effective way to protect piping and equipment from damage caused by pipeline debris. Its large flow area and durable materials of construction means it can withstand the harsh conditions often encountered in refinery and offshore applications. The body port allows for installation of a manual flush valve to clear small amounts of debris from the strainer without removing the cover. For more thorough cleaning, the top cover can easily be removed without taking strainer out of the pipeline.

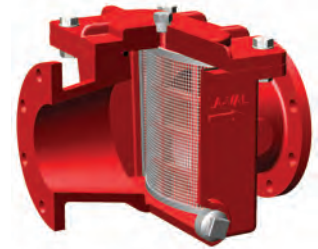

## ***Product Advantages***

The X43HL Strainer provides many product advantages that make it an easy choice when considering the most effective means to protect your system from pipeline debris.

- Available in nickel aluminum bronze with titanium strainer mesh or fusion-bonded epoxy coated ductile iron with 316 Stainless Steel strainer mesh
- Compact profile requires less space than a wye-style strainer which typically has a body configuration that extends well below the pipeline
- Low pressure drop
- Equipped with a plug on both sides of the unit that can be used as drain or flush valves
- Available in 150# class in sizes 2" through 24"
- Lower cost than most other available strainers
- Backed by the assurance that comes from using the most trusted products in the industry

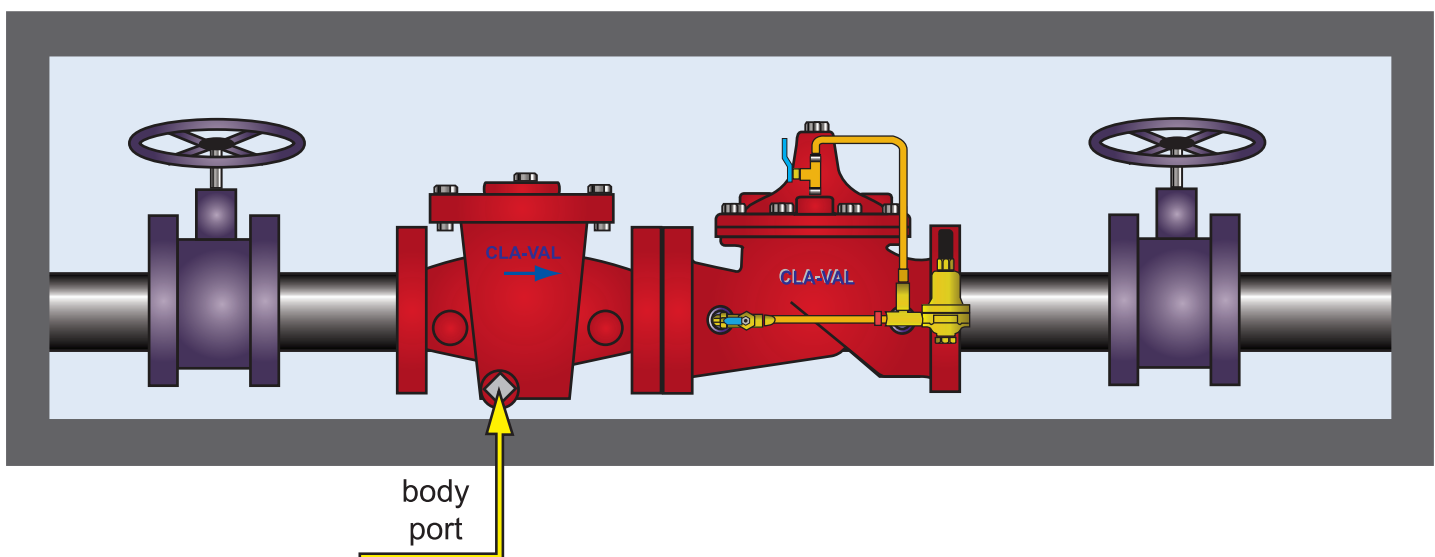

***To learn more, visit [www.cla-val.com](http://www.cla-val.com) and type X43HL in the search field***



# From the street to the sprinkler head: Controlling your fire flow

**Trust the valve with over eighty years of proven performance**

- Pump suction control
- Pump relief control
- Air release
- Pressure reducing
- Check valves
- Direct acting pressure relief

## **Typical Cla-Val Fire Protection Applications in High Rise Buildings**

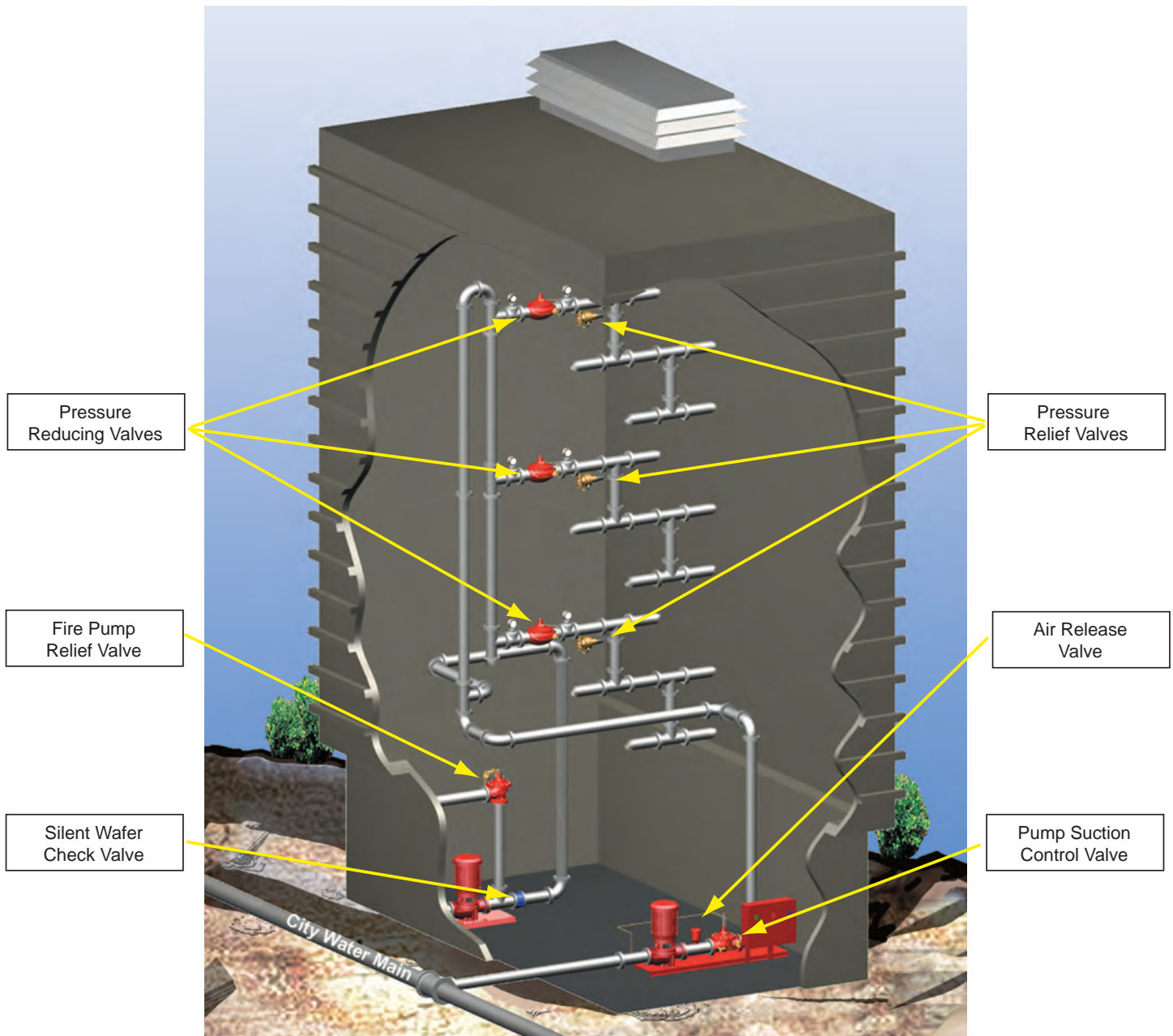

To learn more, visit [www.cla-val.com](http://www.cla-val.com) and click the "High-Rise Fire Protection Applications" Quick Link

# 50B-4KG1- Globe 2050B-4KG1- Angle

MODEL



## Fire Protection Pressure Relief Valve



Type Approved



2050B-4KG1 (Angle)

U.L. Listed.....Sizes 3" thru 8"  
F.M. Approved.....Sizes 3" thru 8"  
U.L.C. Listed.....Sizes 2" thru 10"

- **UL Listed / ULC Listed**
- **Factory Mutual Approved**
- **Fast Opening to Maintain Steady Line Pressure**
- **Accommodates Wide Range of Flow Rates**
- **Closes Gradually for Surge-Free Operation**
- **Adjustable Pressure Settings, Not Affected by Pressure At Valve Discharge**

The Cla-Val Model 50B-4KG1 Globe / 2050B-4KG1 Angle Pressure Relief Valve is designed specifically to automatically relieve excess pressure in fire protection pumping systems. Pilot controlled, it maintains constant system pressure at the pump discharge within very close limits as demands change. The 50B-4KG1 and 2050B-4KG1 can be supplied with optional internal and external epoxy coating of the main valve wetted surfaces.

### Typical Application

KO Model 2050B-4KG1  
Pressure Relief Valve  
(Angle Pattern)

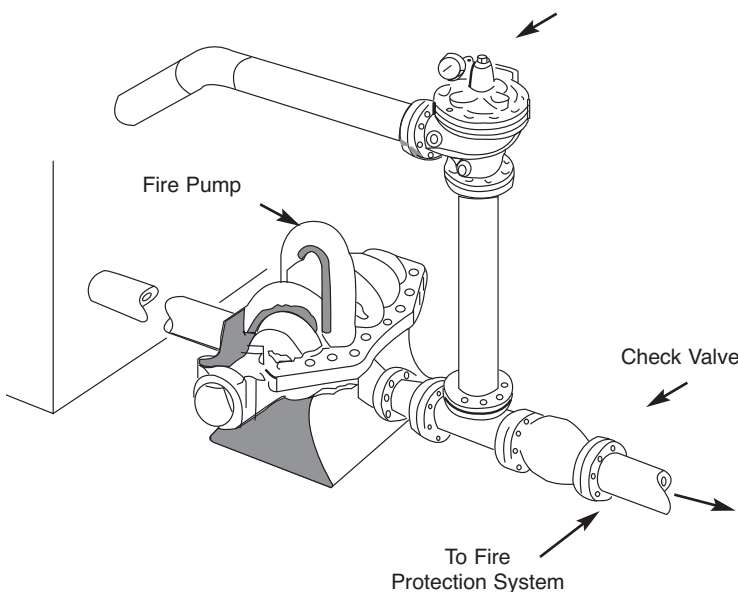

**"Fluid Control at It's Best"**

### Operation Sequence

At pump start, Cla-Val Relief Valve modulates to relieve excess pump capacity, maintaining positive system pressure at the pump discharge.

When fire demand slows or ceases, Cla-Val Model 50B-4KG1 opens, diverting entire pump output to discharge, allowing fire pump to be stopped without causing surging in the lines.

(Please note that if the Model 50B-4KG1 is to be used on a continuous duty basis to maintain fire-system pressure, suitable back pressure must be provided on the valve to prevent cavitation damage. Consult the factory for details.)

#### Optional UL Listed Materials for Seawater and Severe Service Applications:

- Nickel Aluminum Bronze (NAB) - ASTM B148 Alloy C95800
- Monel - QQ-N-288 Comp B - ASTM A494 Grade M30H
- Cast Steel - ASTM A216 Grade WCB
- 316 Stainless Steel - ASTM A743 Grades CF3M and CFM8
- Super Austenitic Stainless Steel - ASTM A351 Grade CK3MCuN (SMO 254)
- Super Duplex Stainless Steel - ASTM A890 Grade 5A (CE3MN)

## Specifications

**Sizes** Globe: 2" - 10" flanged  
Angle: 2" - 10" flanged

**End Details** 150 and 300 ANSI B16.42

**Pressure Ratings** Class 150 - 250 psi Max.  
Class 300 - 300 psi Max.  
Water, to 180°F Max.

**Standard Materials** **Main Valve Body & Cover**  
Ductile Iron ASTM A536 Grade 65-45-12

**Standard Main Valve Trim:**  
Bronze Seat, Teflon Coated  
Stainless Steel Stem, Dura-Kleen Stem

**Standard Pilot Control System:**  
Cast Bronze with  
Stainless Steel trim

Available in the following relief  
pressure ranges:

**Adjustment Range** 20-200 psi (150 Class)  
100-300 psi (300 Class)

**Optional** Protective epoxy resin coating  
of wetted surfaces of main  
valve cast iron components  
(UL listed HNFx EX2855)

## Purchase Specifications

The Fire Pump Pressure Relief Valve shall modulate to relieve excess pressure in a fire protection system. It shall maintain constant pressure in the system regardless of demand changes. It shall be pilot controlled and back pressure shall not affect its set point. It shall be actuated by line pressure through a pilot control system and open fast in order to maintain steady system pressure as system demand decreases. It shall close gradually to control surges and shall re-seat drip-tight within 5% of its pressure setting. The main valve shall be of the hydraulically-operated, pilot-controlled, diaphragm-type, globe or angle valve. It shall have a single, removable, teflon-coated seat, a grooved stem guided at both ends, and a resilient disc with a rectangular cross section, being contained on 3 1/2 sides. No external packing glands shall be permitted and the diaphragm shall not be used as a seating surface. The pilot control shall be a direct-acting, adjustable, spring-loaded, diaphragm-type valve designed for modulating service to permit flow when controlling pressure exceeds spring setting. This valve shall be UL Listed and Factory Mutual approved. It shall be the Model 50B-4KG1 (globe) or Model 2050B-4KG1 (angle) Pressure Relief Valve as manufactured by Cla-Val Newport Beach, California.

### \*Special Note:

The Model 50B-4KG1 Pressure Relief Valve is available with 300# ANSI inlet flange and 150# ANSI outlet flange. This valve is used on higher pressure systems where 300# flange connections are required, and allows for adapting of a discharge cone (generally supplied with 150# flange) to accommodate "atmospheric break" at relief valve discharge. This relief valve, with 300# / 150# flanges is available on special order, and is UNDERWRITERS LABORATORIES LISTED AND FACTORY MUTUAL APPROVED.

## Specifications: Seawater Service Option

**Sizes** Globe: 2" - 8" flanged  
Angle: 2" - 8" flanged

Consult factory for flange ratings.

See page 1 for seawater service materials options.

## Dimensions

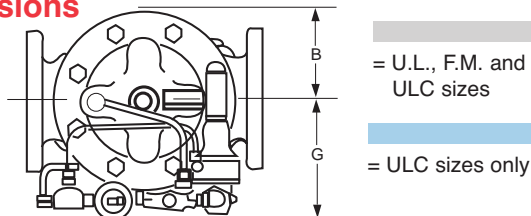

Model 50B-4KG1 Globe

Model 2050B-4KG1 Angle

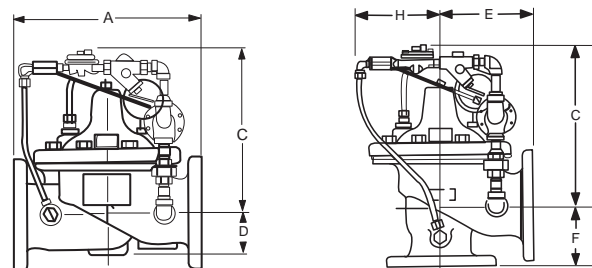

We recommend providing adequate space around valve for maintenance work.

Valve Size (inches)	2"	2-1/2"	3"	4"	6"	8"	10"
<b>Threaded Ends</b>	9.38	11.00	12.50	---	---	---	---
<b>A 150 Flanged</b>	9.38	11.00	12.00	15.00	20.00	25.38	29.75
300 Flanged	10.00	11.62	13.25	15.62	21.00	26.38	31.12
300 X 150			12.88	15.31	20.56	25.88	30.44
<b>B</b>	3.31	4.00	4.56	5.75	7.88	10.00	11.81
<b>C</b>	12.00	12.25	12.50	13.00	14.31	16.31	18.00
<b>D</b>	1.50	1.69	2.66	3.19	4.31	5.31	9.25
<b>Threaded Ends</b>	4.75	5.50	6.25	---	---	---	---
<b>E 150 Flanged</b>	4.75	5.50	6.00	7.50	10.00	12.75	14.88
300 Flanged	5.00	5.88	6.38	7.88	10.50	13.25	15.56
<b>Threaded Ends</b>	3.25	4.00	4.50	---	---	---	---
<b>F 150 Flanged</b>	3.25	4.00	4.00	5.00	6.00	8.00	8.62
300 Flanged	3.50	4.31	4.38	5.31	6.50	8.50	9.31
<b>G &amp; H</b>	6.00	6.69	7.75	7.88	8.50	9.75	13.25

Valve Size (mm)	50	65	80	100	150	200	250
<b>Threaded Ends</b>	238	279	318	---	---	---	---
<b>A 150 Flanged</b>	234	279	305	381	508	645	756
300 Flanged	254	295	337	397	533	670	790
300 X 150	---	---	327	389	522	657	773
<b>B</b>	84	102	116	146	200	254	300
<b>C</b>	305	311	1318	330	363	414	457
<b>D</b>	38	43	65	81	109	135	235
<b>Threaded Ends</b>	121	140	159	---	---	---	---
<b>E 150 Flanged</b>	121	140	152	191	254	324	378
300 Flanged	127	149	162	200	267	337	395
<b>Threaded Ends</b>	83	102	114	---	---	---	---
<b>F 150 Flanged</b>	83	102	102	127	152	203	219
300 Flanged	89	109	111	135	165	216	236
<b>G &amp; H</b>	152	170	197	200	216	248	337

## Valve Capacity

Valve Sizes in Inches:	2"	2 1/2"	3"	4"	6"	8"	10"
NFPA 20 Maximum							
Recommended GPM	208	300	500	1000	2500	5000	11000



E-50B-4KG1/2050B-4KGL1 (R-08/2017)

## CLA-VAL

1701 Placentia Avenue • Costa Mesa CA 92627

800-942-6326 • Fax: 949-548-5441 • Web Site: cla-val.com • E-mail: info@cla-val.com

**CLA-VAL CANADA**  
4687 Christie Drive  
Beamsville, Ontario  
Canada L0R 1B4  
Phone: 905-563-4963  
Fax: 905-563-4040  
E-mail sales@cla-val.ca

**CLA-VAL EUROPE**  
Chemin des Mésanges 1  
CH-1032 Romanell  
Lausanne, Switzerland  
Phone: 41-21-643-15-55  
Fax: 41-21-643-15-50  
E-mail: cla-val@cla-val.ch

**CLA-VAL UK**  
Dainton House, Goods Station Road  
Tunbridge Wells  
Kent TN11 2DH England  
Phone: 44-1892-514-400  
Fax: 44-1892-543-423  
E-mail: info@cla-val.co.uk

**CLA-VAL FRANCE**  
Porte du Grand Lyon 1  
ZAC du Champ du Périer  
France - 01700 Neyron  
Phone: 33-4-72-25-92-93  
Fax: 33-4-72-25-04-17  
E-mail: cla-val@cla-val.fr

**CLA-VAL PACIFIC**  
45 Kennaway Road  
Woolston, Christchurch, 8023  
New Zealand  
Phone: 64-39644860  
www.cla-valpacific.com  
E-mail: info@cla-valpacific.com

# 50B-4KG1KOL Globe 2050B-4KG1KOL Angle

MODELS



Pressure Relief Valve with Anti-Cavitation Trim



Sizes 3" thru 8"



Sizes 3" thru 8"



Type Approved

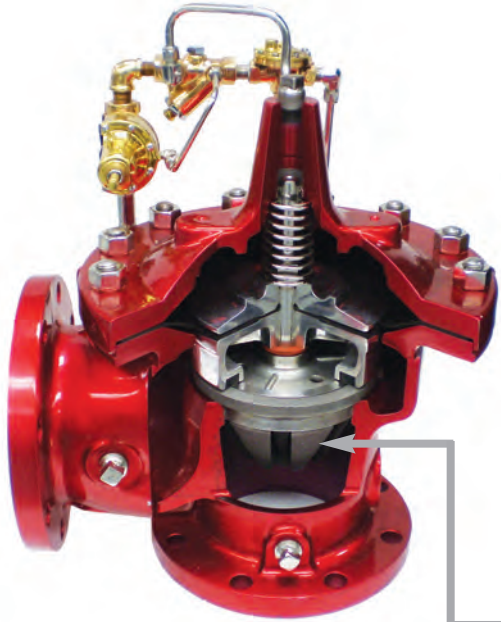

2050B-4KG1KOL (Angle)

- For Onshore and Offshore Applications
- KOL Anti-Cavitation Trim Seat:
  - Protects Against Cavitation
  - Reduces Noise and Vibration
  - Extends Valve Life
- Compliant with NFPA 20 Standards

The Cla-Val Globe Pattern Model 50B-4KG1KOL and Angle Pattern Model 2050B-4KG1KOL relief valve is designed to relieve excess pressure in a fire protection system, while eliminating the damaging effects of cavitation.

The valve features an adjustable pressure setting, fast opening to maintain steady line pressure, and gradual closing for surge free operation.

### KOL Anti-Cavitation Seat Features & Benefits



- Ideal for applications with high pressure differentials
- Meets flow requirements set forth by applicable approval agencies
- Provides a safer work environment by preventing valve damage
- Teflon-Coated Seat available in 316 Stainless Steel, Monel and Super Duplex Stainless Steel

## Typical Applications

### Offshore Platform Pump Relief

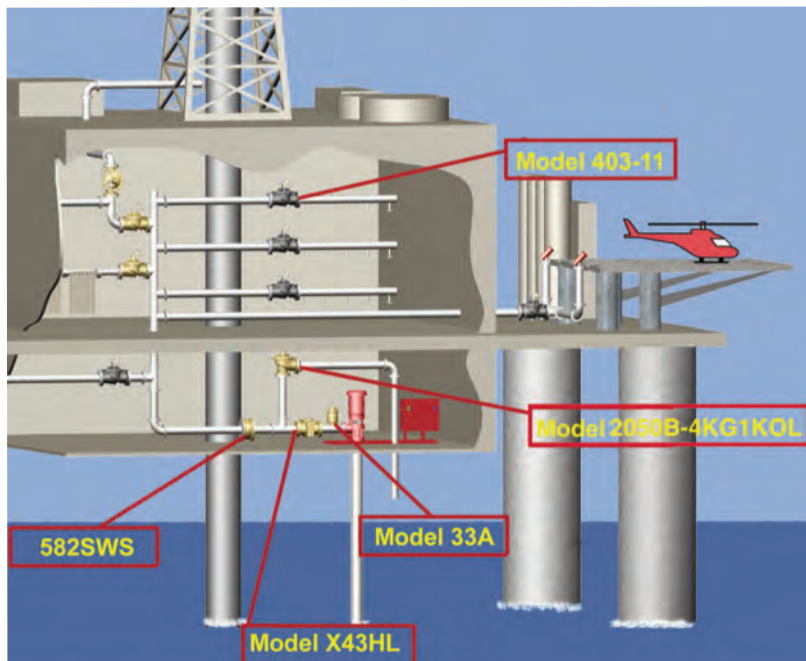

### Onshore Fire Pump Relief

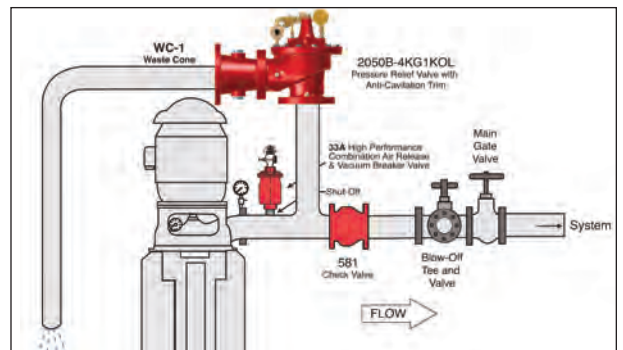

### Optional UL Listed Materials for Seawater and Severe Service Applications:

- Nickel Aluminum Bronze (NAB) - ASTM B148 Alloy C95800
- Monel - QQ-N-288 Comp B - ASTM A494 Grade M30H
- Cast Steel - ASTM A216 Grade WCB
- 316 Stainless Steel - ASTM A743 Grades CF3M and CFM8
- Super Austenitic Stainless Steel - ASTM A351 Grade CK3MCuN (SMO 254)
- Super Duplex Stainless Steel - ASTM A890 Grade 5A (CE3MN)

## Specifications

- Sizes** *Globe:* 3" - 8" flanged; *Angle:* 3" - 8" flanged  
FM Approved, UL and ULC Listed
- End Details** 150 and 300 ANSI B16.42
- Pressure Ratings** Class 150 - 250 psi Max; Class 300 - 300 psi Max  
Water, to 180°F Max.
- Adjustment Range** Available in the following relief pressure ranges:  
20-200 psi (150 Class)  
100-300 psi (300 Class)
- Optional Coating** Protective epoxy resin coating of wetted surfaces of main valve iron components  
UL listed HNFEX EX2855)

### Standard Valve Materials

**Main Valve Body & Cover:** Ductile Iron ASTM A536 Grade 65-45-12  
**Main Valve Trim:** Teflon Coated Stainless Seat, Stainless Steel Stem  
**Pilot Control System:** Cast Bronze with Stainless Steel Trim

### Materials for Seawater and Severe Service Applications

#### Optional UL Listed Materials:

- Nickel Aluminum Bronze (NAB) - ASTM B148 Alloy C95800
- Monel - QQ-N-288 Comp B - ASTM A494 Grade M30H
- Cast Steel - ASTM A216 Grade WCB
- 316 Stainless Steel - ASTM A743 Grades CF3M and CFM8
- Super Austenitic Stainless Steel - ASTM A351 Grade CK3MCuN (SMO 254)
- Super Duplex Stainless Steel - ASTM A890 Grade 5A (CE3MN)

Trim and pilot control system material options available to suit specific applications

## Purchase Specifications

The Fire Pump Pressure Relief Valve shall modulate to relieve excess pressure in a fire protection system, maintaining constant pressure in the system regardless of demand changes. It shall be pilot controlled and back pressure shall not affect its set point. It shall be actuated by line pressure through a pilot control system and open fast in order to maintain steady system pressure as system demand decreases. It shall close gradually to control surges and shall re-seat drip-tight within 5% of its pressure setting.

The main valve shall be of the hydraulically-operated, pilot-controlled, diaphragm-type, globe or angle valve. It shall be equipped with a teflon-coated anti-cavitation seat, a grooved stem guided at both ends, and a resilient disc with a rectangular cross section, being contained on 3-1/2 sides. No external packing glands shall be permitted and the diaphragm shall not be used as a seating surface. The pilot control shall be a direct-acting, adjustable, spring-loaded, diaphragm-type valve designed for modulating service to permit flow when controlling pressure exceeds spring setting. This valve shall be UL Listed and Factory Mutual approved. It shall be the Model 50B-4KG1KOL (globe) or Model 2050B-4KG1KOL (angle) Pressure Relief Valve as manufactured by Cla-Val Newport Beach, California.

#### \*Special Note:

The Model 50B-4KG1KOL/2050B-4KG1KOL Pressure Relief Valve is available with 300# ANSI inlet flange and 150# ANSI outlet flange for high pressure systems where 300# flange connections are required, to allow for adapting of a discharge cone (generally supplied with 150# flange) to accommodate "atmospheric break" at relief valve discharge.

This relief valve, with 300# / 150# flanges is available on special order, and is UNDERWRITERS LABORATORIES LISTED AND FACTORY MUTUAL APPROVED.

## Dimensions

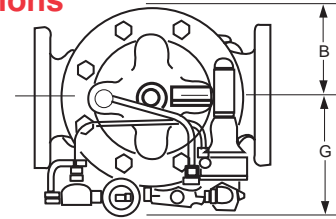

Model 50B-4KGKOL Globe

Model 2050B-4KG1KOL Angle

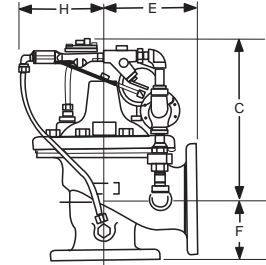
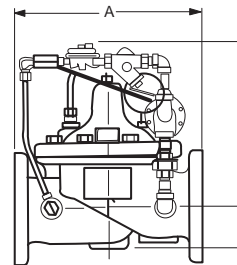

We recommend providing adequate space around valve for maintenance work.

Valve Size (inches)	3"	4"	6"	8"	10"
<b>Threaded Ends</b>	12.50	---	---	---	---
<b>A 150 Flanged</b>	12.00	15.00	20.00	25.38	29.75
300 Flanged	13.25	15.62	21.00	26.38	31.12
300 X 150	12.88	15.31	20.56	25.88	30.44
<b>B</b>	4.56	5.75	7.88	10.00	11.81
<b>C</b>	12.50	13.00	14.31	16.31	18.00
<b>D</b>	2.66	3.19	4.31	5.31	9.25
<b>Threaded Ends</b>	6.25	---	---	---	---
<b>E 150 Flanged</b>	6.00	7.50	10.00	12.75	14.88
300 Flanged	6.38	7.88	10.50	13.25	15.56
<b>Threaded Ends</b>	4.50	---	---	---	---
<b>F 150 Flanged</b>	4.00	5.00	6.00	8.00	8.62
300 Flanged	4.38	5.31	6.50	8.50	9.31
<b>G &amp; H</b>	7.75	7.88	8.50	9.75	13.25

Valve Size (mm)	80	100	150	200	250
<b>Threaded Ends</b>	318	---	---	---	---
<b>A 150 Flanged</b>	305	381	508	645	756
300 Flanged	337	397	533	670	790
300 X 150	327	389	522	657	773
<b>B</b>	116	146	200	254	300
<b>C</b>	1318	330	363	414	457
<b>D</b>	65	81	109	135	235
<b>Threaded Ends</b>	159	---	---	---	---
<b>E 150 Flanged</b>	152	191	254	324	378
300 Flanged	162	200	267	337	395
<b>Threaded Ends</b>	114	---	---	---	---
<b>F 150 Flanged</b>	102	127	152	203	219
300 Flanged	111	135	165	216	236
<b>G &amp; H</b>	197	200	216	248	337

## Valve Capacity

Valve Sizes in Inches:	3"	4"	6"	8"	10"
NFPA 20 Maximum Recommended GPM	500	1000	2500	4000	11000



E-50B-4KG1KOL/2050B-4KG1KOL (R-04/2015)

## CLA-VAL

1701 Placentia Avenue • Costa Mesa CA 92627

800-942-6326 • Fax: 949-548-5441 • Web Site: cla-val.com • E-mail: info@cla-val.com

**CLA-VAL CANADA**  
4687 Christie Drive  
Beamsville, Ontario  
Canada L0R 1B4  
Phone: 905-563-4963  
Fax: 905-563-4040  
E-mail sales@cla-val.ca

**CLA-VAL EUROPE**  
Chemin des Mésanges 1  
CH-1032 Romanel/  
Lausanne, Switzerland  
Phone: 41-21-643-15-50  
Fax: 41-21-643-15-50  
E-mail: cla-val@cla-val.ch

**CLA-VAL UK**  
Dainton House, Goods Station Road  
Tunbridge Wells  
Kent TN1 2 DH England  
Phone: 44-1892-514-400  
Fax: 44-1892-543-423  
E-mail: info@cla-val.co.uk

**CLA-VAL FRANCE**  
Porte du Grand Lyon 1  
ZAC du Champ du Périer  
France - 01700 Neyron  
Phone: 33-4-72-25-92-93  
Fax: 33-4-72-25-04-17  
E-mail: cla-val@cla-val.fr

**CLA-VAL PACIFIC**  
45 Kennaway Road  
Woolston, Christchurch, 8023  
New Zealand  
Phone: 64-39644860  
www.cla-valpacific.com  
E-mail: info@cla-valpacific.com



— MODEL — **WC-1**

# Waste Cone

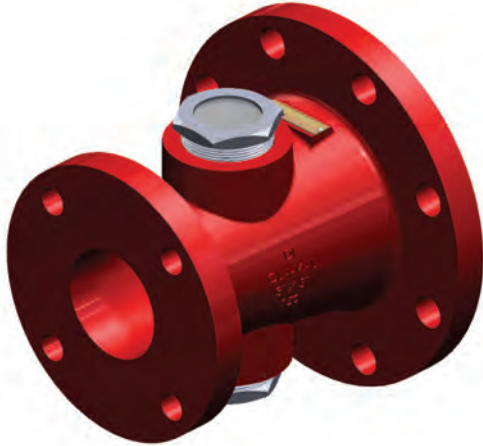

- Available for Onshore and Offshore Applications
- Manufactured in Accordance with NFPA 20 Requirements
- Designed for use with UL/FM Approved Fire Pump Pressure Relief Valves

#### Optional Materials for Seawater and Severe Service Applications:

- Nickel Aluminum Bronze (NAB) - ASTM B148 Alloy C95800
- Monel - QQ-N-288 Comp B - ASTM A494 Grade M30H
- Cast Steel - ASTM A216 Grade WCB
- 316 Stainless Steel - ASTM A743 Grades CF3M and CFM8
- Super Austenitic Stainless Steel - ASTM A351 Grade CK3MCuN (SMO 254)
- Super Duplex Stainless Steel - ASTM A890 Grade 5A (CE3MN)

#### Standards:

- Fusion Bonded Red Epoxy Coated
- Ductile Iron - ASTM A536-65
- (2) 2" 316 SS Sight Glasses per WC-1
- Single Body Casting (No Welding)

#### Flanges

- 150# Class (FF Standard)
- 300# Class (RF Standard)
- Raised Face and Flat Faced Options

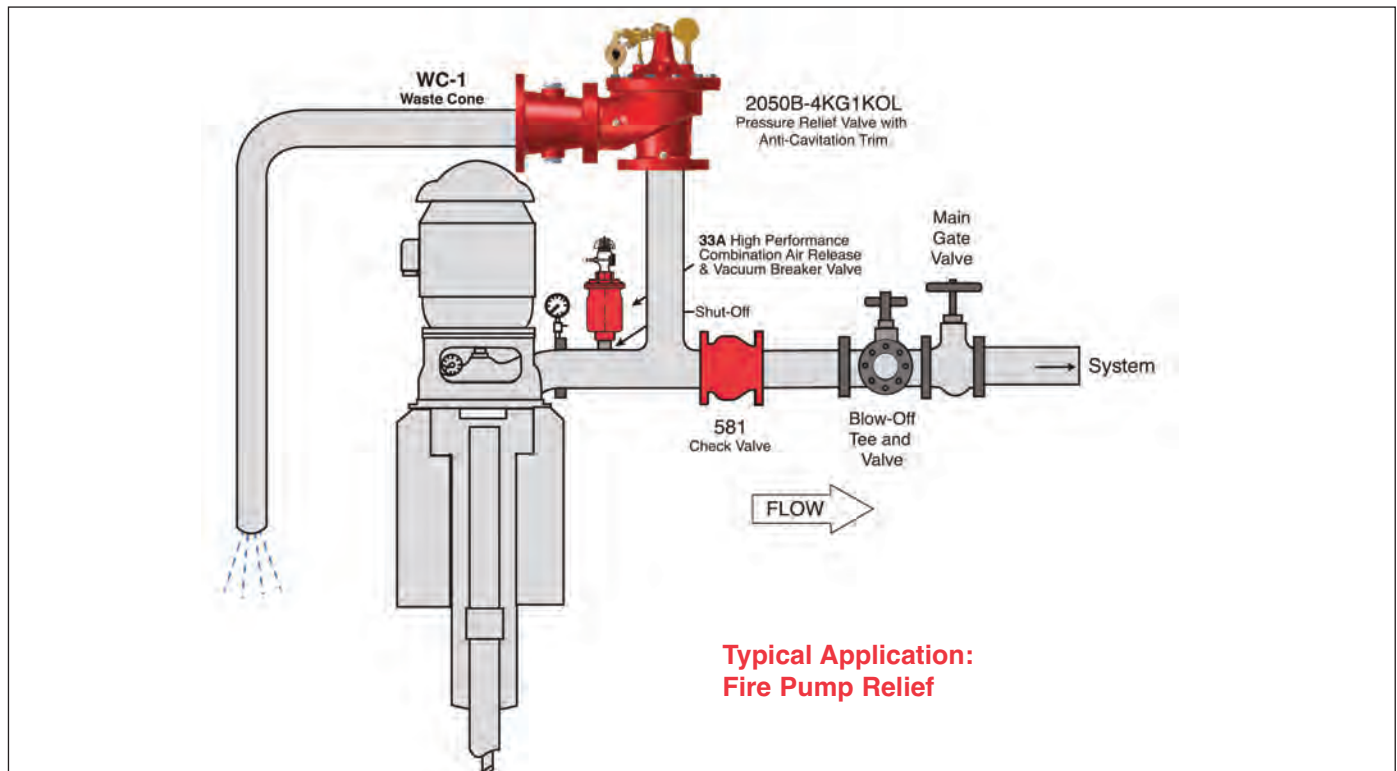

# WC-1

## Technical Data & Dimensions

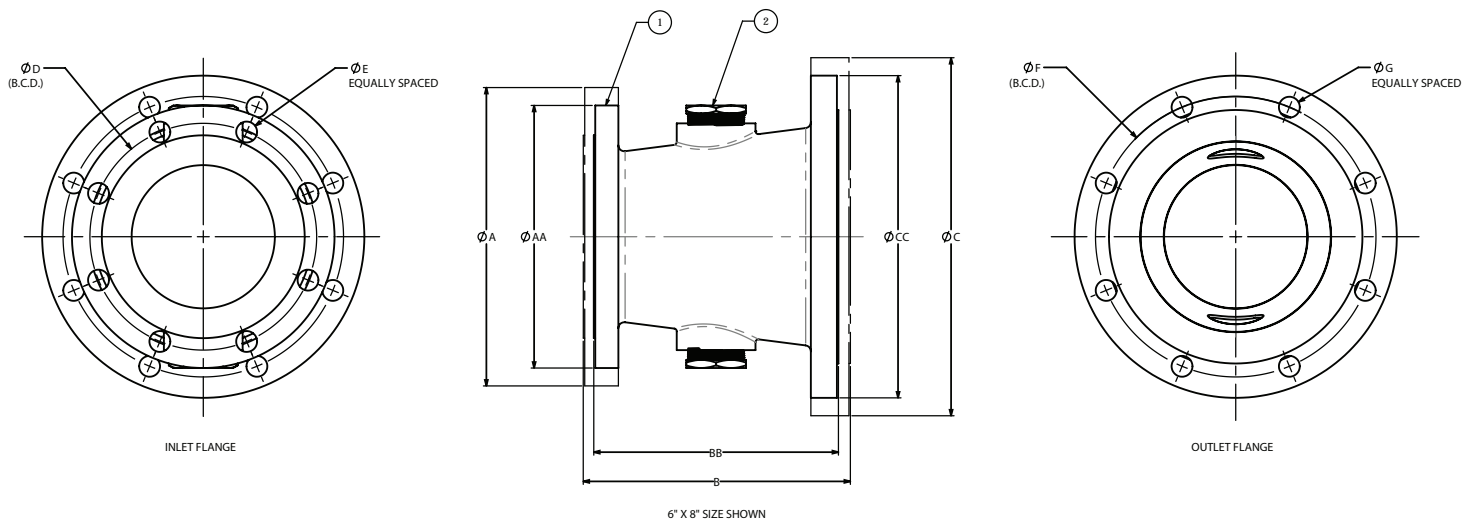

DIMENSION TABLE															
SIZE INLET X OUTLET	PRESSURE CLASS	Ø A	Ø AA	B	BB	Ø C	Ø CC	Ø D (B.C.D.)	Ø E	NUMBER OF HOLES (INLET)	DIAMETER OF BOLTS (INLET)	Ø F (B.C.D.)	Ø G	NUMBER OF HOLES (OUTLET)	DIAMETER OF BOLTS (OUTLET)
3" X 5"	150LB	-	7.50	-	8.25	-	10.00	6.000	.750	4	.625	8.500	.875	8	.750
	300LB	8.25	-	9.24	-	11.00	-	6.625	.875	8	.750	9.250	.875	8	.750
3" X 6"	150LB	-	7.50	-	9.00	-	11.00	6.000	.750	4	.625	9.500	.875	8	.750
	300LB	8.25	-	9.69	-	12.50	-	6.625	.875	8	.750	10.625	.875	12	.750
4" X 6"	150LB	-	9.00	-	9.00	-	11.00	7.500	.750	8	.625	9.500	.875	8	.750
	300LB	10.00	-	9.75	-	12.50	-	7.875	.875	8	.750	10.625	.875	12	.750
4" X 8"	150LB	-	9.00	-	10.25	-	13.50	7.500	.750	8	.625	11.750	.875	8	.750
	300LB	10.00	-	11.06	-	15.00	-	7.875	.875	8	.750	13.000	1.000	12	.875
6" X 8"	150LB	-	11.00	-	10.25	-	13.50	9.500	.875	8	.750	11.750	.875	8	.750
	300LB	12.50	-	11.19	-	15.00	-	10.625	.875	12	.750	13.000	1.000	12	.875
6" X 10"	150LB	-	11.00	-	11.50	-	16.00	9.500	.875	8	.750	14.250	1.000	12	.875
	300LB	12.50	-	12.63	-	17.50	-	10.625	.875	12	.750	15.250	1.125	16	1.000
8" X 12"	150LB	-	13.50	-	13.00	-	19.00	11.750	.875	8	.750	17.000	1.000	12	.875
	300LB	15.00	-	14.25	-	20.50	-	13.000	1.000	12	.875	17.750	1.250	16	1.125
8" X 14"	150LB	-	13.50	-	14.00	-	21.00	11.750	.875	8	.750	18.750	1.125	12	1.000
	300LB	15.00	-	15.25	-	23.00	-	13.000	1.000	12	.875	20.250	1.250	20	1.125

Visit [www.cla-val.com](http://www.cla-val.com) to learn more about Cla-Val Fire Protection Products



E-WC-1 (R-05-2017)

## CLA-VAL

1701 Placentia Avenue • Costa Mesa CA 92627

800-942-6326 • Fax: 949-548-5441 • Web Site: [cla-val.com](http://cla-val.com) • E-mail: [info@cla-val.com](mailto:info@cla-val.com)

**CLA-VAL CANADA**  
4687 Christie Drive  
Beamsville, Ontario  
Canada L0R 1B4  
Phone: 905-563-4963  
Fax: 905-563-4040  
E-mail: [sales@cla-val.ca](mailto:sales@cla-val.ca)

**CLA-VAL EUROPE**  
Chemin des Mésanges 1  
CH-1032 Romanel/  
Lausanne, Switzerland  
Phone: 41-21-643-15-55  
Fax: 41-21-643-15-50  
E-mail: [cla-val@cla-val.ch](mailto:cla-val@cla-val.ch)

**CLA-VAL UK**  
Dainton House, Goods Station Road  
Tunbridge Wells  
Kent TN11 2 DH England  
Phone: 44-1892-514-400  
Fax: 44-1892-543-423  
E-mail: [info@cla-val.co.uk](mailto:info@cla-val.co.uk)

**CLA-VAL FRANCE**  
Porte du Grand Lyon 1  
ZAC du Champ du Périer  
France - 01700 Neyron  
Phone: 33-4-72-25-92-93  
Fax: 33-4-72-25-04-17  
E-mail: [cla-val@cla-val.fr](mailto:cla-val@cla-val.fr)

**CLA-VAL PACIFIC**  
45 Kennaway Road  
Woolston, Christchurch, 8023  
New Zealand  
Phone: 64-39644860  
[www.cla-valpacific.com](http://www.cla-valpacific.com)  
E-mail: [info@cla-valpacific.com](mailto:info@cla-valpacific.com)

COPYRIGHT CLA-VAL 2018 Printed in USA Specifications subject to change without notice.

# 50B-5KG — MODEL —



## Pump Suction Control Valve

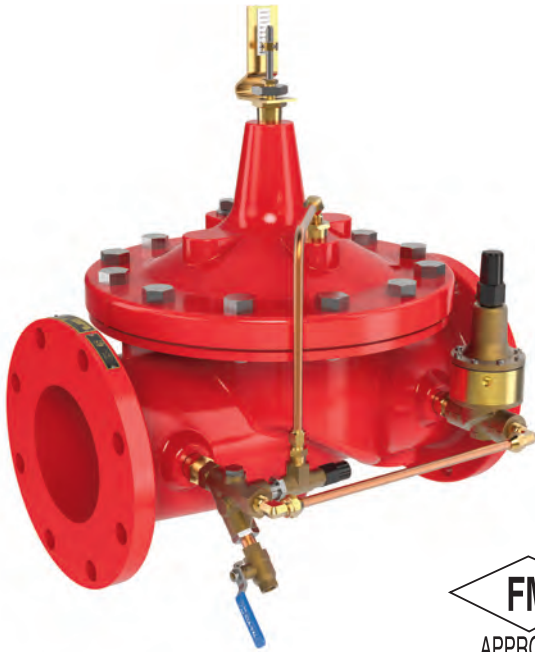

- Adjustable Opening Speed For Pump Suction Protection
- Pilot Control Provides Wide Flow Range With Minimal Pressure Variations
- Controlled Closing For System Protection
- Modulates Within 5% of Setting for Accurate Pressure Control
- Pressure Setting Adjustable
- Pressure Setting Not Affected by Pressure at Valve Discharge

The Model 50B-5KG Pump Suction Control Valve is designed specifically for Fire Pump Suction Control Service. It modulates to maintain the pump discharge in relation to the suction head available, thus assuring that the suction head pressure does not fall below the pre-set minimum.

### Typical Installation

When there is a demand in the Fire System, the pump is started, delivering water from the supply source to the area of demand. To assure that the fire pump draw does not exceed the available water supply, the Model 50B-5KG, sensing the pump suction, modulates to prevent suction pressure from dropping below a pre-set minimum.

By maintaining minimum pressure requirements in the supply main, the main is protected from possible damage or backflow conditions. Also, a minimum supply pressure is provided for local fire apparatus.

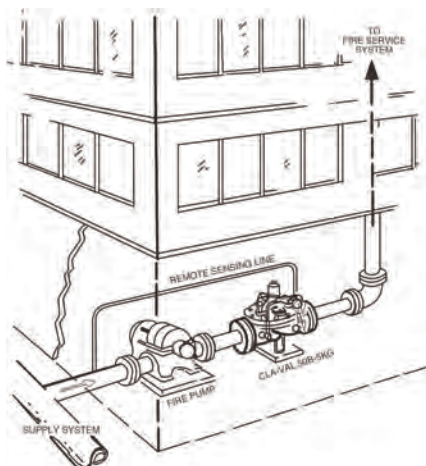

### Specifications

**Sizes** Globe: 3" - 8" flanged  
Angle: 3" - 8" flanged

**End Details** 150 and 300 ANSI B16.42

**Pressure Ratings** 150 class - 250 psi Max.  
300 class - 400 psi Max

**Temperature Range** Water, to +180°F Max.

**Materials** **Main valve body & cover**  
Ductile Iron ASTM A-536

**Main valve trim:**  
Brass QQ-B-626  
Bronze Seat ASTM B61  
Stainless Steel Stem 303  
Delrin Sleeved

**Pilot control system:**  
Cast Bronze ASTM B62 with  
303 Stainless Steel trim

**Adjustment Range** Available in the following pressure range only:  
5 to 25 psi  
Set at 10 psi

## Dimensions (in Inches)

## Flow Chart

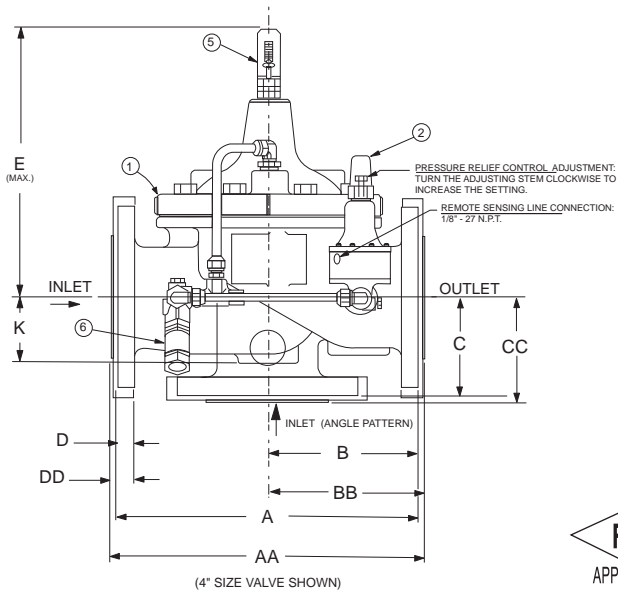

Item No.	Description
1	100KCGVX Hytrol (Main Valve)
2	CRL5A Pressure Relief Control
3	X44A Strainer and Orifice Assembly
4	CV Flow Control (Opening)
5	X101C Valve Position Indicator
6	CK2 (Blow-Off Valve)

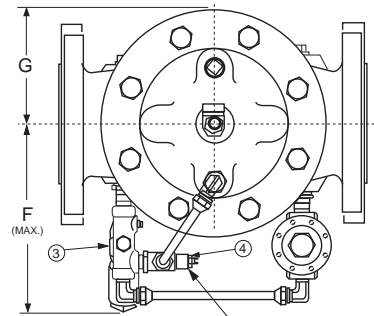
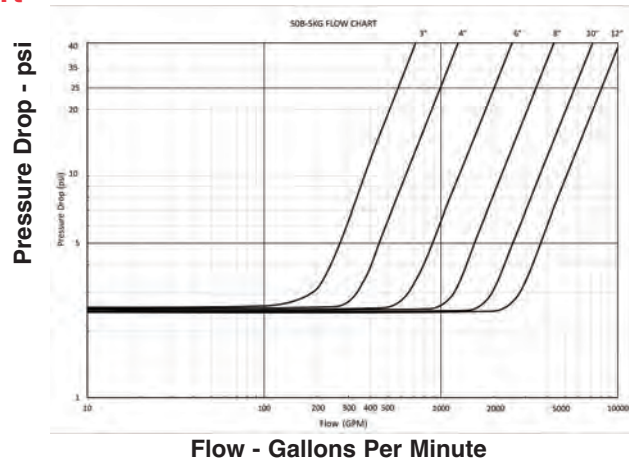

VALVE SIZE	A 150 LB. FLANGES	AA 300 LB. FLANGES	B 150 LB. FLANGES	BB 300 LB. FLANGES	C 150 LB. FLANGES	CC 300 LB. FLANGES	D (TYP.) 150 LB. FLANGES (MIN.)	DD (TYP.) 300 LB. FLANGES (MIN.)	E (MAX.)	F (MAX.)	G (MAX.)	K
3"	12.00	13.25	6.00	6.38	4.00	4.38	.75	1.12	15.75	13.50	4.62	2.56
4"	15.00	15.62	7.50	7.88	5.00	5.31	.94	1.25	17.75	15.00	5.75	3.19
6"	20.00	21.00	10.00	10.50	6.00	6.50	1.00	1.44	20.25	16.50	7.88	4.31
8"	25.38	26.38	12.75	13.25	8.00	8.50	1.12	1.62	23.00	20.00	10.00	5.31

## Purchase Specifications

The Fire Pump Suction Control Valve shall modulate to maintain a minimum pressure at the pump suction regardless of system demand. It shall control the pump discharge in relation to the suction head available, and shall not allow suction head pressure to fall below a pre-set minimum.

It shall be actuated by line pressure through a pilot control system which allows rapid response to changing pressure conditions without line surges. The pilot control shall be remote sensed to the pump suction head pressure.

The main valve shall be of the hydraulically-operated, pilot-controlled, diaphragm-type, globe or angle valve. It shall have a single removable seat, a delrin-sleeved guided stem and a renewable resilient synthetic rubber disc with a rectangular cross section, contained on three and one-half sides by a disc

retainer and disc guide. No external packing glands shall be permitted and the diaphragm shall not be used as a seating surface. The pilot control shall be a direct-acting, adjustable, spring-loaded, diaphragm-type valve designed for modulating service to permit flow when controlling pressure exceeds spring setting.

A device indicating the percent at which the valve is open or closed shall be supplied on the assembly, together with a sediment evacuator and dampening device.

The valve shall be designed to allow for repair and servicing without removing the valve body from the line.

The valve shall be Factory Mutual Approved. It shall be the MODEL 50B-5KG FIRE PUMP SUCTION CONTROL VALVE as manufactured by Cla-Val, Newport Beach, California.



## CLA-VAL

1701 Placentia Avenue • Costa Mesa CA 92627

800-942-6326 • Fax: 949-548-5441 • Web Site: [cla-val.com](http://cla-val.com) • E-mail: [info@cla-val.com](mailto:info@cla-val.com)

**CLA-VAL CANADA**  
4687 Christie Drive  
Beamsville, Ontario  
Canada L0R 1B4  
Phone: 905-563-4963  
Fax: 905-563-4040  
E-mail: [sales@cla-val.ca](mailto:sales@cla-val.ca)

**CLA-VAL EUROPE**  
Chemin des Mésanges 1  
CH-1032 Romanel/  
Lausanne, Switzerland  
Phone: 41-21-643-15-55  
Fax: 41-21-643-15-50  
E-mail: [cla-val@cla-val.ch](mailto:cla-val@cla-val.ch)

**CLA-VAL UK**  
Dainton House, Goods Station Road  
Tunbridge Wells  
Kent TN11 2 DH England  
Phone: 44-1892-514-400  
Fax: 44-1892-543-423  
E-mail: [info@cla-val.co.uk](mailto:info@cla-val.co.uk)

**CLA-VAL FRANCE**  
Porte du Grand Lyon 1  
ZAC du Champ du Pérrier  
France - 01700 Neyron  
Phone: 33-4-72-25-92-93  
Fax: 33-4-72-25-04-17  
E-mail: [cla-val@cla-val.fr](mailto:cla-val@cla-val.fr)

**CLA-VAL PACIFIC**  
45 Kennaway Road  
Woolston, Christchurch, 8023  
New Zealand  
Phone: 64-39644860  
[www.cla-valpacific.com](http://www.cla-valpacific.com)  
E-mail: [info@cla-valpacific.com](mailto:info@cla-valpacific.com)

# 50-20 — MODEL —



## Seawater Service Pressure Relief Valve



50A-20 (Angle)

### Schematic Diagram

#### Item Description

- 1 100S/2100S Hytrol (Main Valve)
- 2 CRL Pressure Relief Control
- 3 X44A Strainer & Orifice Assy
- 4 81-01 Check Valve

### Optional Features

#### Item Description

- B CK2 (Isolation Valves)
- C CV Flow Control (Closing)
- F Remote Pilot Sensing
- H Drain to Atmosphere
- S CV Flow Control (Opening)

Please note that if the Model 50-20 is to be used on a continuous duty basis to maintain fire-system pressure, suitable back pressure must be provided on the valve to prevent cavitation damage. Consult the factory for details.

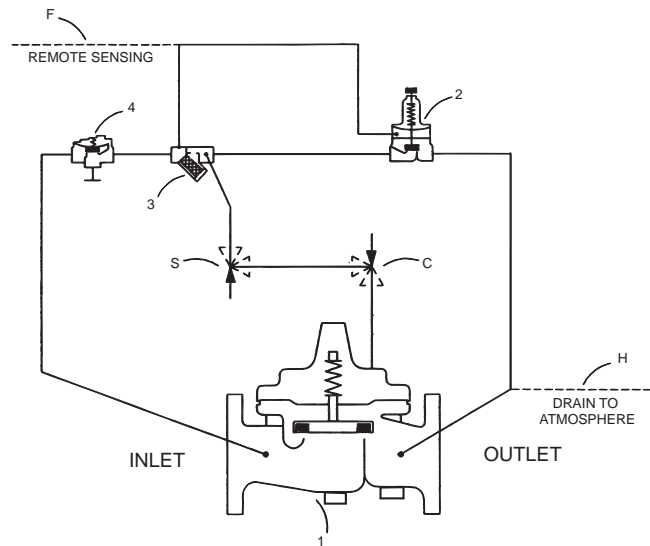

- Fast Opening to Maintain Steady Line Pressure
- Accommodates Wide Range of Flow Rates
- Closes Gradually for Surge-Free Operation
- Adjustable Pressure Settings, Not Affected by Pressure At Valve Discharge

The Cla-Val Model 50-20 Seawater Service Pressure Relief Valve is designed specifically to automatically relieve excess pressure in fire protection pumping systems. Pilot controlled, it maintains constant system pressure at the pump discharge within very close limits as demands change.

### Specification

**Sizes:** Threaded Ends: 1 1/2" - 3"  
Globe Flanged: 2" - 36"  
Angle Flanged: 2" - 16"

**End Details:** Cast Steel ANSI B16.5  
Bronze ANSI B16.24  
Stainless Steel ANSI B16.5  
Ductile Iron ANSI B16.42

**Pressure** 150 Class 250 psi Max.  
**Ratings:** 300 Class 400 psi Max.

#### Temperature

**Range:** Water 180°F Max.

**Materials:** **Main valve body & cover**  
Ductile Iron ASTM A-536\*  
Cast Steel ASTM A216-WCB\*  
Naval Bronze ASTM B61  
Stainless Steel ASTM A743-CF-8M  
Ni. AL. Bronze ASTM B148  
Super Duplex SST

#### Main valve trim:

ASTM B61 Bronze Seat,  
Monel Trim

#### Pilot control system:

Cast Bronze with Monel Trim  
Monel, Super Duplex Stainless Steel optional  
Stainless Steel 316 Tubing & Fittings

**Adjustment** 20 - 200 psi (150 class)  
**Ranges:** 100 - 300 psi (300 class)

\*The 50G-20 (globe) and 50A-20 (angle) in cast steel are supplied with standard internal and external epoxy coating

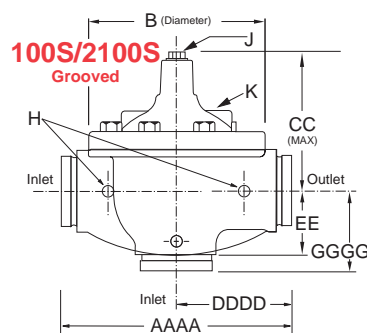
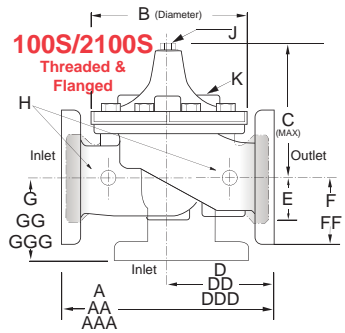

Valve Size (Inches)	1	1 1/4	1 1/2	2	2 1/2	3	4	6	8	10	12	14	16	18	20	24	30	36
A Threaded	7.25	7.25	7.25	9.38	11.00	12.50	—	—	—	—	—	—	—	—	—	—	—	—
AA 150 ANSI	—	—	8.50	9.38	11.00	12.00	15.00	20.00	25.38	29.75	34.00	39.00	41.38	46.00	52.00	61.50	63.00	76.00
AAA 300 ANSI	—	—	9.00	10.00	11.62	13.25	15.62	21.00	26.38	31.12	35.50	40.50	43.50	47.64	53.62	63.24	64.50	76.00
AAAA Grooved End	—	—	8.50	9.00	11.00	12.50	15.00	20.00	25.38	—	—	—	—	—	—	—	—	—
B Dia.	5.62	5.62	5.62	6.62	8.00	9.12	11.50	15.75	20.00	23.62	28.00	32.75	35.50	41.50	45.00	53.16	56.00	66.00
C Max.	5.50	5.50	5.50	6.50	7.56	8.19	10.62	13.38	16.00	17.12	20.88	24.19	25.00	39.06	41.90	43.93	54.60	61.50
CC Max. Grooved End	—	—	4.75	5.75	6.88	7.25	9.31	12.12	14.62	—	—	—	—	—	—	—	—	—
D Threaded	3.25	3.25	3.25	4.75	5.50	6.25	—	—	—	—	—	—	—	—	—	—	—	—
DD 150 ANSI	—	—	4.00	4.75	5.50	6.00	7.50	10.00	12.69	14.88	17.00	19.50	20.81	—	—	30.75	—	—
DDD 300 ANSI	—	—	4.25	5.00	5.88	6.38	7.88	10.50	13.25	15.56	17.75	20.25	21.62	—	—	31.62	—	—
DDDD Grooved End	—	—	—	4.75	—	6.00	7.50	—	—	—	—	—	—	—	—	—	—	—
E	1.12	1.12	1.12	1.50	1.69	2.06	3.19	4.31	5.31	9.25	10.75	12.62	15.50	12.95	15.00	17.75	21.31	24.56
EE Grooved End	—	—	2.00	2.50	2.88	3.12	4.25	6.00	7.56	—	—	—	—	—	—	—	—	—
F 150 ANSI	—	—	2.50	3.00	3.50	3.75	4.50	5.50	6.75	8.00	9.50	10.50	11.75	15.00	16.50	19.25	22.50	25.60
FF 300 ANSI	—	—	3.06	3.25	3.75	4.13	5.00	6.25	7.50	8.75	10.25	11.50	12.75	15.00	16.50	19.25	24.00	25.60
G Threaded	1.88	1.88	1.88	3.25	4.00	4.50	—	—	—	—	—	—	—	—	—	—	—	—
GG 150 ANSI	—	—	4.00	3.25	4.00	4.00	5.00	6.00	8.00	8.62	13.75	14.88	15.69	—	—	22.06	—	—
GGG 300 ANSI	—	—	4.25	3.50	4.31	4.38	5.31	6.50	8.50	9.31	14.50	15.62	16.50	—	—	22.90	—	—
GGGG Grooved End	—	—	—	3.25	—	4.25	5.00	—	—	—	—	—	—	—	—	—	—	—
H NPT Body Tapping	.375	.375	.375	.375	.50	.50	.75	.75	1	1	1	1	1	1	1	1	2	2
J NPT Cover Center Plug	.25	.25	.25	.50	.50	.50	.75	.75	1	1	1.25	1.5	2	1.5	1.5	1.5	2	2
K NPT Cover Tapping	.375	.375	.375	.375	.50	.50	.75	.75	1	1	1	1	1	1	1	1	2	2
Stem Travel	0.4	0.4	0.4	0.6	0.7	0.8	1.1	1.7	2.3	2.8	3.4	4.0	4.5	5.1	5.63	6.75	7.5	8.5
Approx. Ship Wt. Lbs.	15	15	15	35	50	70	140	285	500	780	1165	1600	2265	2982	3900	6200	7703	11720
Valve Size (mm)	25	32	40	50	65	80	100	150	200	250	300	350	400	450	500	600	750	900
A Threaded	184	184	184	238	279	318	—	—	—	—	—	—	—	—	—	—	—	—
AA 150 ANSI	—	—	216	238	279	305	381	508	645	756	864	991	1051	1168	1321	1562	1600	1930
AAA 300 ANSI	—	—	229	254	295	337	397	533	670	790	902	1029	1105	1210	1362	1606	1638	1930
AAAA Grooved End	—	—	216	228	279	318	381	508	645	—	—	—	—	—	—	—	—	—
B Dia.	143	143	143	168	203	232	292	400	508	600	711	832	902	1054	1143	1350	1422	1676
C Max.	140	140	140	165	192	208	270	340	406	435	530	614	635	992	1064	1116	1387	1562
CC Max. Grooved End	—	—	120	120	146	175	184	236	308	371	—	—	—	—	—	—	—	—
D Threaded	83	83	83	121	140	159	—	—	—	—	—	—	—	—	—	—	—	—
DD 150 ANSI	—	—	102	121	140	152	191	254	322	378	432	495	528	—	—	781	—	—
DDD 300 ANSI	—	—	108	127	149	162	200	267	337	395	451	514	549	—	—	803	—	—
DDDD Grooved End	—	—	—	121	—	152	191	—	—	—	—	—	—	—	—	—	—	—
E	29	29	29	38	43	52	81	110	135	235	273	321	394	329	381	451	541	624
EE Grooved End	—	—	52	64	73	79	108	152	192	—	—	—	—	—	—	—	—	—
F 150 ANSI	—	—	64	76	89	95	114	140	171	203	241	267	298	381	419	489	572	650
FF 300 ANSI	—	—	78	83	95	105	127	159	191	222	260	292	324	381	419	489	610	650
G Threaded	48	48	48	83	102	114	—	—	—	—	—	—	—	—	—	—	—	—
GG 150 ANSI	—	—	102	83	102	102	127	152	203	219	349	378	399	—	—	560	—	—
GGG 300 ANSI	—	—	102	89	110	111	135	165	216	236	368	397	419	—	—	582	—	—
GGGG Grooved End	—	—	—	83	—	108	127	—	—	—	—	—	—	—	—	—	—	—
H NPT Body Tapping	.375	.375	.375	.375	.50	.50	.75	.75	1	1	1	1	1	1	1	1	2	2
J NPT Cover Center Plug	.25	.25	.25	.50	.50	.50	.75	.75	1	1	1.25	1.5	2	1.5	1.5	1.5	2	2
K NPT Cover Tapping	.375	.375	.375	.375	.50	.50	.75	.75	1	1	1	1	1	1	1	1	2	2
Stem Travel	10	10	10	15	18	20	28	43	58	71	86	102	114	130	143	171	190	216
Approx. Ship Wt. Kgs.	7	7	7	16	23	32	64	129	227	354	528	726	1027	1353	1769	2812	3494	5316

### Valve Capacity

Valve Size (inches)	1	1 1/4	1 1/2	2	2 1/2	3	4	6	8	10	12	14	16	18	20	24	30	36
Max. Continuous GPM	55	93	125	210	300	460	800	1800	3100	4900	7000	8400	11000	14000	17000	25000	42000	50000
Max Surge GPM	120	210	280	470	670	1000	1800	4000	7000	11000	16000	19000	25000	31000	39000	56500	63000	85000

### Purchase Specifications

The Fire Pump Pressure Relief Valve shall modulate to relieve excess pressure in a fire protection system. It shall maintain constant pressure in the system regardless of demand changes. It shall be pilot controlled and back pressure shall not affect its set point. It shall be actuated by line pressure through a pilot control system and open fast in order to maintain steady system pressure as system demand decreases. It shall close gradually to control surges and shall re-seat drip-tight within 5% of its pressure setting. The main valve shall be of the hydraulically-operated, pilot-controlled, diaphragm-type, globe or angle valve. It shall have a single, removable, teflon-coated seat. Internal and exter-

We recommend providing adequate space around valve for maintenance work.

nal epoxy coating, a stem guided at both ends, and a resilient disc with a rectangular cross section, being contained on 3 1/2 sides. No external packing glands shall be permitted and the diaphragm shall not be used as a seating surface. The pilot control shall be a direct-acting, adjustable, spring-loaded, diaphragm-type valve designed for modulating service to permit flow when controlling pressure exceeds spring setting. It shall be the MODEL 50G-20 (globe) or Model 50A-20 (angle) Pressure Relief Valve as manufactured by Cla-Val, Newport Beach, California.

# 50-49 — MODEL —



## Seawater Service Pump Start Pressure Relief Valve



Type Approved

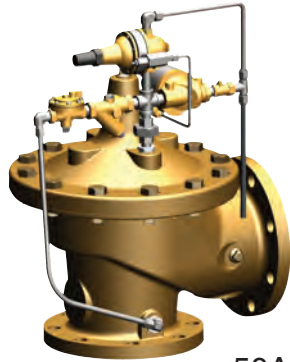

50A-49

- Seawater Service Materials
- Reduced Cavitation Design
- Drip-tight, Positive Seating Action
- Globe or Angle Pattern for Model 50-49
- Every Valve Factory-Tested
- Three Year Warranty

Cla-Val Model 50-49 Pump Start / Pressure Relief Valve provides pump and pipeline protection during pump start sequence and pump operation when discharge pressure rises to unsafe levels.

Cla-Val Model 50-49 Pump Start / Pressure Relief Valve available in sizes 2" - 36" in both globe and angle pattern.

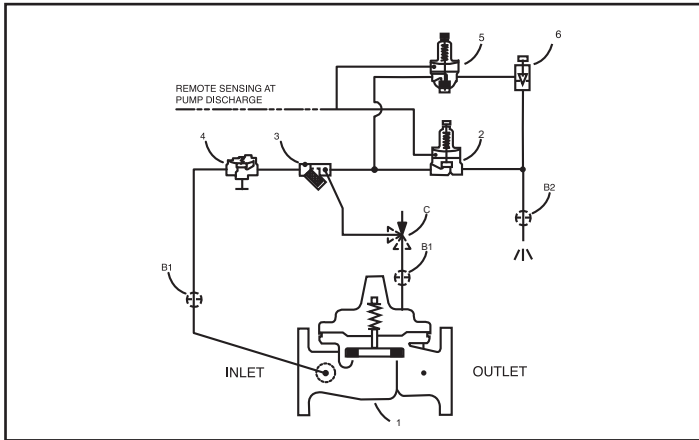

### Schematic Diagram

- | Item | Description                    |
|------|--------------------------------|
| 1    | 100S/2100S Hytrol (Main Valve) |
| 2    | CRL Pressure Relief Control    |
| 3    | X44A Strainer & Orifice Assy   |
| 4    | 81-01 Check Valve              |
| 5    | CRA Pressure Reducing Control  |
| 6    | CNA Needle Valve (Opening)     |

### Optional Features

- | Item | Description               |
|------|---------------------------|
| B    | CK2 (Isolation Valves)    |
| C    | CV Flow Control (Closing) |

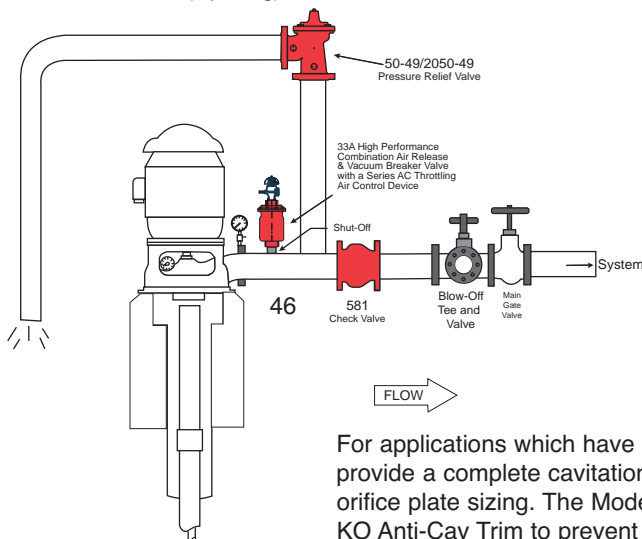

### Operation:

The Model 50-49 has both a normally open and normally closed pilot controls. The valve mounts on a pipe tee at the pump discharge and provides pipeline protection at pump start-up through the normally open pilot control. This pilot will be open to vent the relief valve cover chamber and enable the relief valve to be open at pump start. When the pump first starts, the relief valve relieves both air and start-up water pressure to atmosphere and protects the pump discharge piping from accelerated pressure spikes. The spring loaded pilot with adjustable spring range will slowly close and divert the system pressure into system eliminating unsafe pressure spikes which can damage or rupture discharge piping.

Should the discharge pump pressure continue to rise due to little or no system demand, the normally closed pilot provides overpressure protection by relieving excess pressure to atmosphere as long as the relief valve inlet pressure is greater than the pilot pressure setting. This pilot has various adjustable spring ranges to meet the system pressure requirements.

### Materials:

#### Main Valve Body & Cover:

- Ductile Iron ASTM A-536
- Cast Steel ASTM A216-WCB
- Naval Bronze ASTM B61
- Stainless Steel ASTM A743-CF-8M
- Ni. AL. Bronze ASTM B148

#### Main Valve Trim:

ASTM B61 Bronze Seat, Monel Trim

#### Pilot Control System:

- Cast Bronze with Monel Trim
- Monel, Super Duplex Stainless Steel Optional
- Stainless Steel 316 Tubing & Fittings

For applications which have cavitation issues, Cla-Val can provide a complete cavitation analysis and recommend orifice plate sizing. The Model 50-49 can be fitted with KO Anti-Cav Trim to prevent cavitation.

## Model 50-49 Dimensions

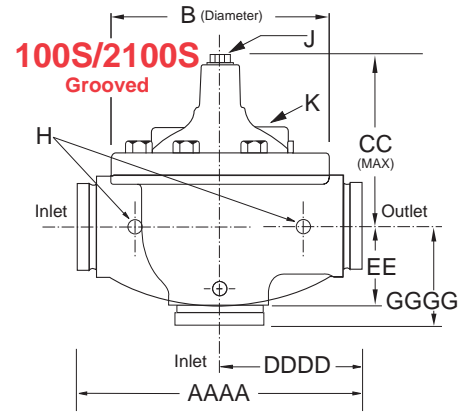
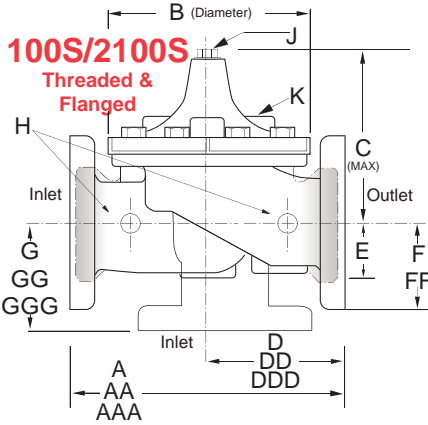

Valve Size (Inches)	1	1 1/4	1 1/2	2	2 1/2	3	4	6	8	10	12	14	16	18	20	24	30	36
A Threaded	7.25	7.25	7.25	9.38	11.00	12.50	—	—	—	—	—	—	—	—	—	—	—	—
AA 150 ANSI	—	—	8.50	9.38	11.00	12.00	15.00	20.00	25.38	29.75	34.00	39.00	41.38	46.00	52.00	61.50	63.00	76.00
AAA 300 ANSI	—	—	9.00	10.00	11.62	13.25	15.62	21.00	26.38	31.12	35.50	40.50	43.50	47.64	53.62	63.24	64.50	76.00
AAAA Grooved End	—	—	8.50	9.00	11.00	12.50	15.00	20.00	25.38	—	—	—	—	—	—	—	—	—
B Dia.	5.62	5.62	5.62	6.62	8.00	9.12	11.50	15.75	20.00	23.62	28.00	32.75	35.50	41.50	45.00	53.16	56.00	66.00
C Max.	5.50	5.50	5.50	6.50	7.56	8.19	10.62	13.38	16.00	17.12	20.88	24.19	25.00	39.06	41.90	43.93	54.60	61.50
CC Max. Grooved End	—	—	4.75	5.75	6.88	7.25	9.31	12.12	14.62	—	—	—	—	—	—	—	—	—
D Threaded	3.25	3.25	3.25	4.75	5.50	6.25	—	—	—	—	—	—	—	—	—	—	—	—
DD 150 ANSI	—	—	4.00	4.75	5.50	6.00	7.50	10.00	12.69	14.88	17.00	19.50	20.81	—	—	30.75	—	—
DDD 300 ANSI	—	—	4.25	5.00	5.88	6.38	7.88	10.50	13.25	15.56	17.75	20.25	21.62	—	—	31.62	—	—
DDDD Grooved End	—	—	—	4.75	—	6.00	7.50	—	—	—	—	—	—	—	—	—	—	—
E	1.12	1.12	1.12	1.50	1.69	2.06	3.19	4.31	5.31	9.25	10.75	12.62	15.50	12.95	15.00	17.75	21.31	24.56
EE Grooved End	—	—	2.00	2.50	2.88	3.12	4.25	6.00	7.56	—	—	—	—	—	—	—	—	—
F 150 ANSI	—	—	2.50	3.00	3.50	3.75	4.50	5.50	6.75	8.00	9.50	10.50	11.75	15.00	16.50	19.25	22.50	25.60
FF 300 ANSI	—	—	—	3.06	3.25	3.75	4.13	5.00	6.25	7.50	8.75	10.25	11.50	12.75	15.00	16.50	19.25	24.00
G Threaded	1.88	1.88	1.88	3.25	4.00	4.50	—	—	—	—	—	—	—	—	—	—	—	—
GG 150 ANSI	—	—	—	4.00	3.25	4.00	4.00	5.00	6.00	8.00	8.62	13.75	14.88	15.69	—	—	22.06	—
GGG 300 ANSI	—	—	—	4.25	3.50	4.31	4.38	5.31	6.50	8.50	9.31	14.50	15.62	16.50	—	—	22.90	—
GGGG Grooved End	—	—	—	3.25	—	4.25	5.00	—	—	—	—	—	—	—	—	—	—	—
H NPT Body Tapping	.375	.375	.375	.375	.50	.50	.75	.75	1	1	1	1	1	1	1	1	2	2
J NPT Cover Center Plug	.25	.25	.25	.50	.50	.50	.75	.75	1	1	1.25	1.5	2	1.5	1.5	1.5	2	2
K NPT Cover Tapping	.375	.375	.375	.375	.50	.50	.75	.75	1	1	1	1	1	1	1	1	2	2
Stem Travel	0.4	0.4	0.4	0.6	0.7	0.8	1.1	1.7	2.3	2.8	3.4	4.0	4.5	5.1	5.63	6.75	7.5	8.5
Approx. Ship Wt. Lbs.	15	15	15	35	50	70	140	285	500	780	1165	1600	2265	2982	3900	6200	7703	11720

### Model 50-49 Functional Data (Uses Basic Valve Model 100-01)

Valve Size	Inches	1	1 1/4	1 1/2	2	2 1/2	3	4	6	8	10	12	14	16	18	20	24	30	36	
	mm.	25	32	40	50	65	80	100	150	200	250	300	350	400	450	500	600	750	900	
C <sub>v</sub> Factor	Globe Pattern	Gal./Min. (gpm.)	13.3	30	32	54	85	115	200	440	770	1245	1725	2300	3130	3725	5345	7655	10150	14020
		Litres/Sec. (l/s.)	3.2	7.2	7.7	13	20	28	48	106	185	299	414	552	752	894	1286	1837	2436	3200
	Angle Pattern	Gal./Min. (gpm.)	27	27	29	61	101	139	240	541	990	1575	2500*	3060*	4200*	—	—	—	—	—
		Litres/Sec. (l/s.)	6.5	6.5	7	15	24	33	58	130	238	378	600	734	1008	—	—	—	—	—
Equivalent Length of Pipe	Globe Pattern	Feet (ft.)	23	19	37	51	53	85	116	211	291	347	467	422	503	612	595	628	1181	2285
		Meters (m.)	7.1	5.7	12	15.5	16	26	35	64	89	106	142	129	154	187	181	192	552	569
	Angle Pattern	Feet (ft.)	28	28	46	40	37	58	80	139	176	217	222*	238*	247*	—	—	—	—	—
		Meters (m.)	8.7	8.7	14	12	11	18	25	43	54	66	68	73	75	—	—	—	—	—
K Factor	Globe Pattern	6.1	3.6	5.9	5.6	4.6	6.0	5.9	6.2	6.1	5.8	6.1	5.0	5.2	5.2	4.6	4.0	5.3	7.8	
	Angle Pattern	4.4	4.4	7.1	4.4	3.3	4.1	4.1	4.1	3.7	3.6	2.9	2.8	2.6	—	—	—	—	—	
Liquid Displaced from Cover Chamber When Valve Opens	Fl. Oz	—	—	—	—	—	—	—	—	—	—	—	—	—	—	—	—	—	—	
	U.S. Gal.	.02	.02	.02	.03	.04	.08	.17	.53	1.26	2.51	4.0	6.5	9.6	11	12	29	42	90	
	ml	20.7	75.7	75.7	121	163	303	643	—	—	—	—	—	—	—	—	—	—	—	
	Litres	—	—	—	—	—	—	—	2.0	4.8	9.5	15.1	24.6	36.2	41.6	45.4	109.8	197	340	

### Valve Capacity

Valve Size (inches)	1	1 1/4	1 1/2	2	2 1/2	3	4	6	8	10	12	14	16	18	20	24	30	36
Max. Continuous GPM	55	93	125	210	300	460	800	1800	3100	4900	7000	8400	11000	14000	17000	25000	42000	50000
Max Surge GPM	120	210	280	470	670	1000	1800	4000	7000	11000	16000	19000	25000	31000	39000	56500	63000	85000

# 55L-60 — MODEL —

## Pressure Relief Valve/ Pump Casing Relief Valve



1/2" and 3/4"  
Globe  
Configuration

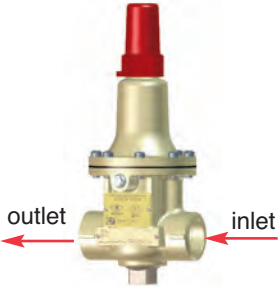

0-75 psi  
20-200 psi

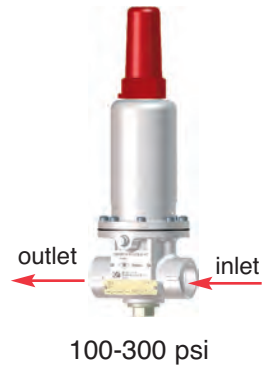

1/2", 3/4" and 1"  
Angle Configuration

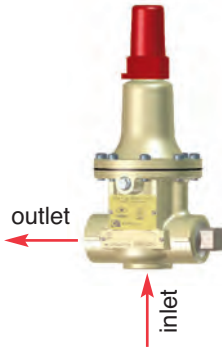

1" Size  
20-75 psi  
40-200 psi  
100-300 psi

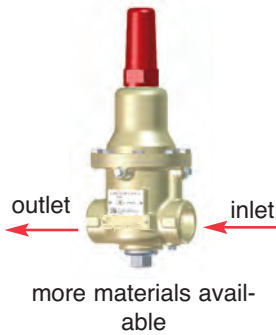

- Available sizes 1/2", 3/4" and 1"
- UL Listed/FM Approved for use as a Fire Pump Casing Relief Valve
- Direct Acting - Precise Pressure Control
- Drip Tight Closure
- No Packing Glands or Stuffing Boxes
- Globe or Angle configurations available
- Sensitive to Small Pressure Variations
- Meets low lead requirements
- Available in Cast Bronze, 316 Stainless Steel, Monel and Super Duplex Stainless Steel

The Cla-Val Model 55L-60 (UL Listed, FM Approved) Pressure Relief Valve is a direct-acting, spring loaded, diaphragm type relief valve. The valve may be installed in any position and will open and close within very close pressure limits. The bottom plug may be removed and installed in the inlet to convert it to an angle pattern flow path.

The Model 55L-60 is normally held closed by the force of the compression spring above the diaphragm. When the controlling pressure applied under the diaphragm exceeds the spring setting, the disc is lifted off its seat, permitting flow through the control. When control pressure drops below the spring setting, the spring forces the control back to its normally closed position. The controlling pressure is applied to the chamber beneath the diaphragm through an internal passage. A gauge port is provided for accurate pressure setting.

Pressure adjustment is done by turning the adjusting screw to vary the spring load on the diaphragm. The 55L-60 is available in pressure ranges suited to agency approval tests. To prevent tampering, the adjustment cap can be wire sealed by using the lock wire holes provided in the cap and cover.



**Fire Protection System Service**  
The **Model 55L-60** is typically used in a fire protection system to trim water pressure, thus preventing pressure build-up whenever line pressure exceeds the setting of the spring.

The 55L-60 will relieve excess pressure to atmosphere to prevent damage to the distribution network.

NOTE: Model 55L-60 is not suitable for discharging the full-rated pump capacity of a fire pump. See Model 50B-4KG1 Fire Pump Relief Valve for such applications.

### Typical Application for Fresh Water or Seawater Service

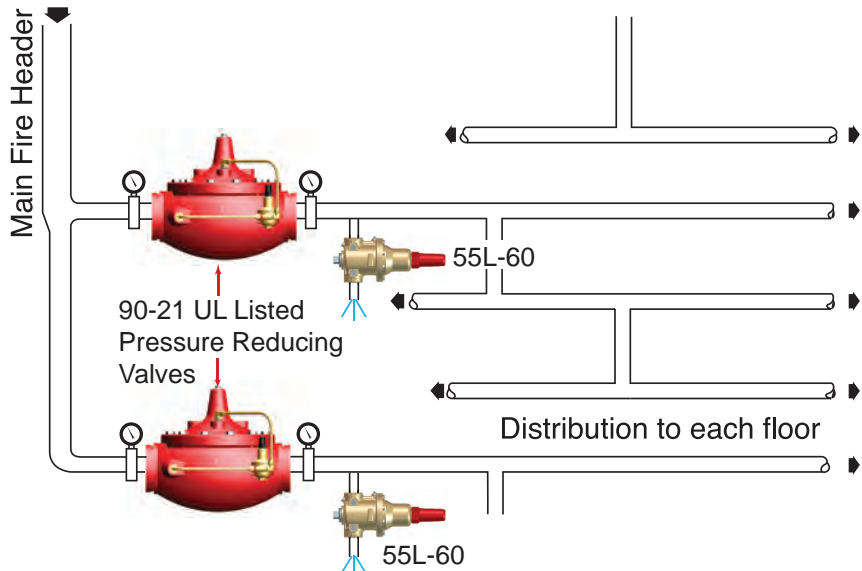

## Specifications

**Size** 1/2", 3/4" and 1" Threaded NPT

**Temperature Range** Water, Air: to 180°F Max.

### Materials

**Body & Cover:** Cast Bronze UNS C87850 -Standard  
Stainless Steel ASTM A743-CF-16F  
Monel  
Super Duplex Stainless Steel

**Trim:** 303 Stainless Steel  
Monel

**Rubber:** Buna-N® Synthetic Rubber

**Pressure Ratings** Cast Bronze 400 psi Max.  
Stainless Steel 400 psi Max.

**Other Materials** Available on special order

### Adjustment Ranges UL Listed

10 to 75 psi • 20 to 200 psi • 100 to 300 psi

### Adjustment Ranges FM Approved

0 to 75 psi • 20 to 200 psi • 100 to 300 psi

## Pressure Drop Chart (Full Open Valve)

Valve Size	C <sub>V</sub> Factor	Max Flow (GPM)
1/2"	6	25
3/4"	8.5	40
1"	12.8	65

### When Ordering, Please Specify

1. Catalog No. 55L-60
2. Valve Size
3. Adjustment Range Desired
4. Optional Materials

## Dimensions (1/2" and 3/4")

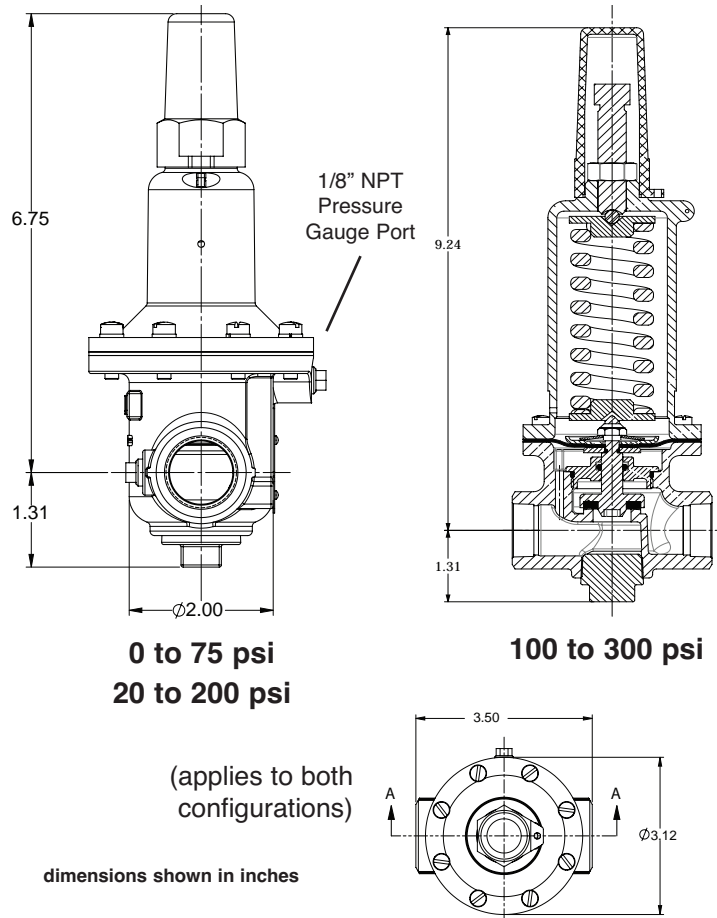

## Dimensions (1"):

### Spring Range:

20-75  
40-200  
100-300

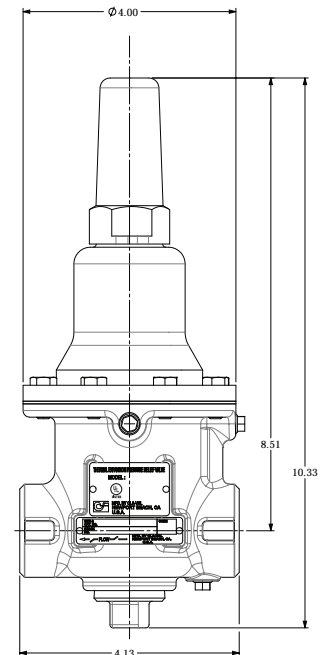

E-55L-60 (R-07/2016)

## CLA-VAL

1701 Placentia Avenue • Costa Mesa CA 92627

800-942-6326 • Fax: 949-548-5441 • Web Site: [cla-val.com](http://cla-val.com) • E-mail: [info@cla-val.com](mailto:info@cla-val.com)

### CLA-VAL CANADA

4687 Christie Drive  
Beamsville, Ontario  
Canada L0R 1B4  
Phone: 905-563-4963  
Fax: 905-563-4040  
E-mail sales@cla-val.ca

### CLA-VAL EUROPE

Chemin des Mésanges 1  
CH-1032 Romanel/  
Lausanne, Switzerland  
Phone: 41-21-643-15-55  
Fax: 41-21-643-15-50  
E-mail: [cla-val@cla-val.ch](mailto:cla-val@cla-val.ch)

### CLA-VAL UK

Dainton House, Goods Station Road  
Tunbridge Wells  
Kent TN11 2 DH England  
Phone: 44-1892-514-400  
Fax: 44-1892-543-423  
E-mail: [info@cla-val.co.uk](mailto:info@cla-val.co.uk)

### CLA-VAL FRANCE

Porte du Grand Lyon 1  
ZAC du Champ du Pérrier  
France - 01700 Neyron  
Phone: 33-4-72-25-92-93  
Fax: 33-4-72-25-04-17  
E-mail: [cla-val@cla-val.fr](mailto:cla-val@cla-val.fr)

### CLA-VAL PACIFIC

45 Kennaway Road  
Woolston, Christchurch, 8023  
New Zealand  
Phone: 64-39644860  
[www.cla-valpacific.com](http://www.cla-valpacific.com)  
E-mail: [info@cla-valpacific.com](mailto:info@cla-valpacific.com)

COPYRIGHT CLA-VAL 2018 Printed in USA Specifications subject to change without notice.

# 850B-4 — MODEL —

## 800 Series (Tubular Diaphragm Valve)

### Fire Relief Valve



- Low Head Loss
- One Spring for all Pressure Ranges between 30 and 200 PSIG
- Cast Steel Construction
- Pressure Excursions Do Not Exceed 3% of Set Pressure
- Fusion Coated Epoxy Inside and Out
- Anti-Cavitation Design
- Nickel Aluminum Bronze Construction Option (Alloy C95800)
- Duplex Stainless Steel Construction Option (Alloy 2205)
- Low Maintenance
- Simple and Reliable Operation
- 1-Year Warranty

The Cla-Val Model 850B-4 Fire Relief Valve is a pressure-operated, in-line axial valve. A tube diaphragm actuates the valve, which is comprised of three major components: 1) Tube 2) Barrier and 3) Body. There is only one moving part in the valve — the tube diaphragm. There are no shafts, packing, stem guides or springs.

The tube diaphragm is a one piece, homogeneous nitrile rubber part which is extremely durable. The ends of the tube are thick solid rubber, designed to fit between mating flanges. This design eliminates the possibility of cutting the tube diaphragm due to over tightening or piping misalignment during installation.

The tube forms a drip tight seal around the barrier when the pressure is equalized between the valve inlet and the control chamber. When pressure is removed from the control chamber, the valve is open. The minimum recommended operating pressure is 40 P.S.I. of inlet pressure.



### Principle of Operation

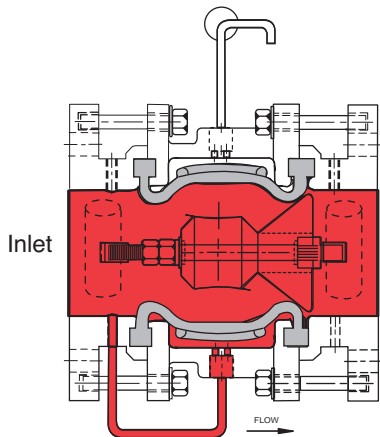

**Full Open Operation**

The valve opens when pilot set pressure is reached and pressure in the control chamber is relieved.

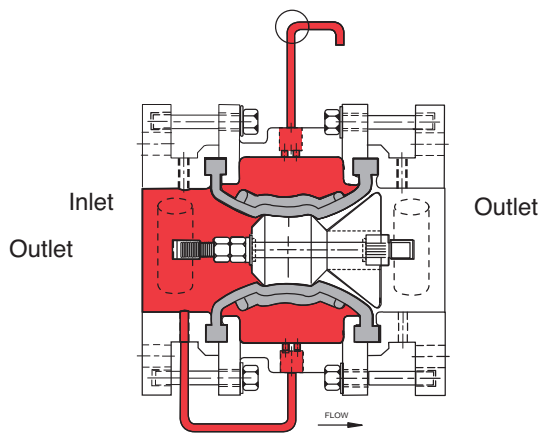

**Tight Closing Operation**

Water pressure (equal to inlet pressure) from valve inlet or from upstream of valve is applied to the control chamber. Valve closes bubble tight.

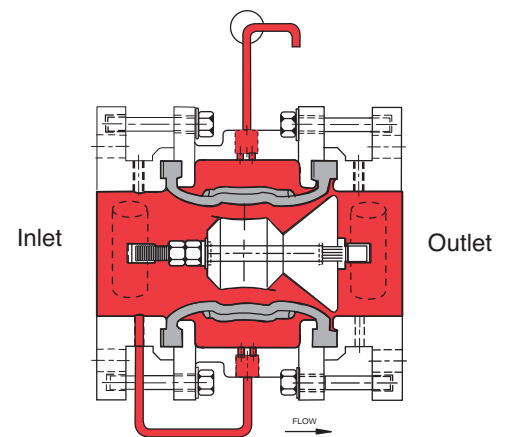

**Modulating Action**

The valve tube diaphragm holds any intermediate position when a quantity of water is exhausted from the control chamber via the pilot. The quantity of water in the control chamber is established by the "set pressure" of the pilot.

The control chamber is filled or exhausted to atmosphere, maintaining "set pressure."

## Dimensions

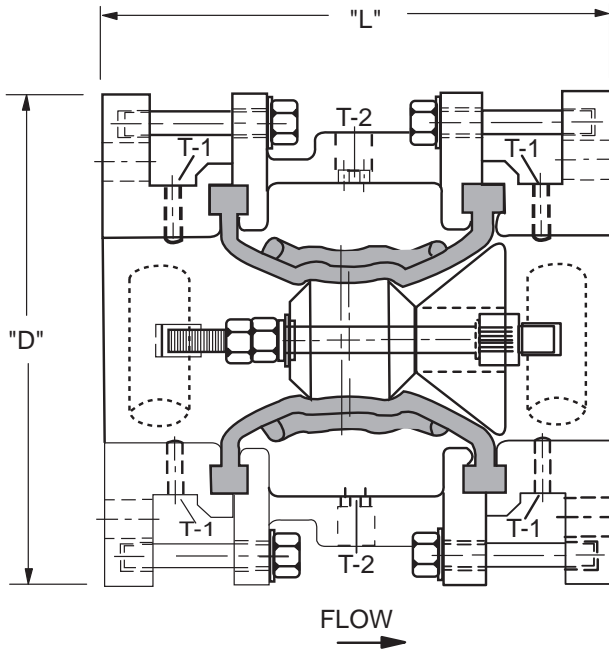

## Model 850B-4

Valve Size (Inches)	3	4	6	8	10
L	8.75	9.75	10.75	11.75	14.00
D	7.5	9.5	11.75	14.00	16.44
T-1	1/4	1/4	3/8	3/8	1/2
T-2	1/2	1/2	1/2	1/2	1/2
Approx. Wt. (Lbs.)	67	99	135	185	270

Valve Size (mm)	80	100	150	200	250
L	222	248	273	299	356
D	191	241	299	356	418
T-1	1/4	1/4	3/8	3/8	1/2
T-2	1/2	1/2	1/2	1/2	1/2
Approx. Wt. (kgs.)	30	45	61	84	123

4", 6", 8" Factory Mutual Approved (with approved Pilot Components)

FLOW FACTORS		
SIZE (IN)	CV (gpm)	KV
3"	160	36.4
4"	340	77.3
6"	885	201
8"	1667	379
*10"	2424	550

Valve Capacity\* \*Calculated

Valve Sizes	3"	4"	6"	8"	10"
NFPA 20 Maximum Recommended GPM	500	1000	2500	5000	11000

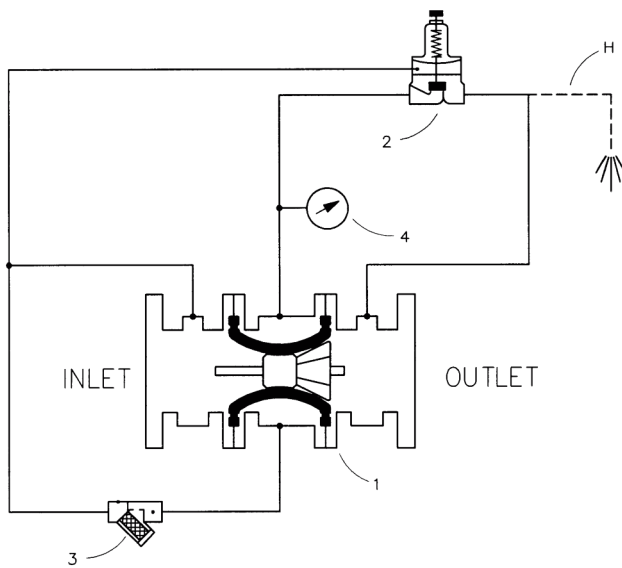

## 850B-4 Basic Components

Item	Description
1	100-43 TDV Main Valve
2	CRL Pressure Relief Control
3	X44A Strainer and Orifice Assembly
4	Pressure Gauge

Cla-Val 800 Series Control Valves operate with maximum efficiency when mounted in horizontal or vertical piping. Adequate space above and around the valve for service personnel should be considered essential. A regular maintenance program should be established based on the specific application data. However, we recommend a thorough inspection be done at least once a year. Consult factory for specific recommendations.

## MAIN VALVE

Ends:	Flanged ANSI B16.5 (150lb Class)
Body:	Cast Steel (ASTM A216 WCB)
Tube Diaphragm:	Nitrile Rubber
Barrier:	Urethane
Bolts:	316 SS
Pressure:	250 psig (17.24 BAR)
Temp. Range:	32° F to 180° F (0° C to 82.2° C)

## MAIN VALVE OPTIONS

Body:	Nickel Aluminum Bronze (Alloy C95800) or Duplex SS (Alloy 2205)
-------	---

## PILOT VALVE

All Parts:	Bronze / Stainless Steel
O-Rings:	Nitrile Rubber
Control:	Controls Pressure Excursions within 3% of Set Point
Spring Range:	30 to 200 PSIG
Operation:	Normally Closed; Opens at Set Pressure; Modulates

## PILOT VALVE OPTIONS

All Wetted Parts:	Monel (Alloy 400)
-------------------	-------------------



## CLA-VAL

1701 Placentia Avenue • Costa Mesa CA 92627  
800-942-6326 • Fax: 949-548-5441 • Web Site: cla-val.com • E-mail: info@cla-val.com

### CLA-VAL CANADA

4687 Christie Drive  
Beamsville, Ontario  
Canada L0R 1B4  
Phone: 905-563-4963  
Fax: 905-563-4040  
E-mail sales@cla-val.ca

### CLA-VAL EUROPE

Chemin des Mésanges 1  
CH-1032 Romanel/  
Lausanne, Switzerland  
Phone: 41-21-643-15-55  
Fax: 41-21-643-15-50  
E-mail: cla-val@cla-val.ch

### CLA-VAL UK

Dainton House, Goods Station Road  
Tunbridge Wells  
Kent TN1 2 DH England  
Phone: 44-1892-514-400  
Fax: 44-1892-543-423  
E-mail: info@cla-val.co.uk

### CLA-VAL FRANCE

Porte du Grand Lyon 1  
ZAC du Champ du Périer  
France - 01700 Neyron  
Phone: 33-4-72-25-92-93  
Fax: 33-4-72-25-04-17  
E-mail: cla-val@cla-val.fr

### CLA-VAL PACIFIC

45 Kennaway Road  
Woolston, Christchurch, 8023  
New Zealand  
Phone: 64-39644860  
www.cla-valpacific.com  
E-mail: info@cla-valpacific.com

# 850-20 — MODEL —

## 800 Series (Tubular Diaphragm Valve)

### Seawater Relief Valve



- Low Head Loss
- One Spring for all Pressure Ranges between 30 and 200 PSIG
- Cast Steel Construction
- Pressure Excursions Do Not Exceed 3% of Set Pressure
- Fusion Coated Epoxy Inside and Out
- Anti-Cavitation Design
- Nickel Aluminum Bronze Construction Option (Alloy C95800)
- Duplex Stainless Steel Construction Option (Alloy 2205)
- Low Maintenance
- Simple and Reliable Operation
- 1-Year Warranty

The Cla-Val Model 850-20 Seawater Relief Valve is a pressure-operated, in-line axial valve. A tube diaphragm actuates the valve, which is comprised of three major components: 1) Tube 2) Barrier and 3) Body. There is only one moving part in the valve — the tube diaphragm. There are no shafts, packing, stem guides or springs.

The tube diaphragm is a one piece, homogeneous nitrile rubber part which is extremely durable. The ends of the tube are thick solid rubber, designed to fit between mating flanges. This design eliminates the possibility of cutting the tube diaphragm due to over tightening or piping misalignment during installation.

The tube forms a drip tight seal around the barrier when the pressure is equalized between the valve inlet and the control chamber. When pressure is removed from the control chamber, the valve is open. The minimum recommended operating pressure is 40 P.S.I. of inlet pressure.

### Principle of Operation

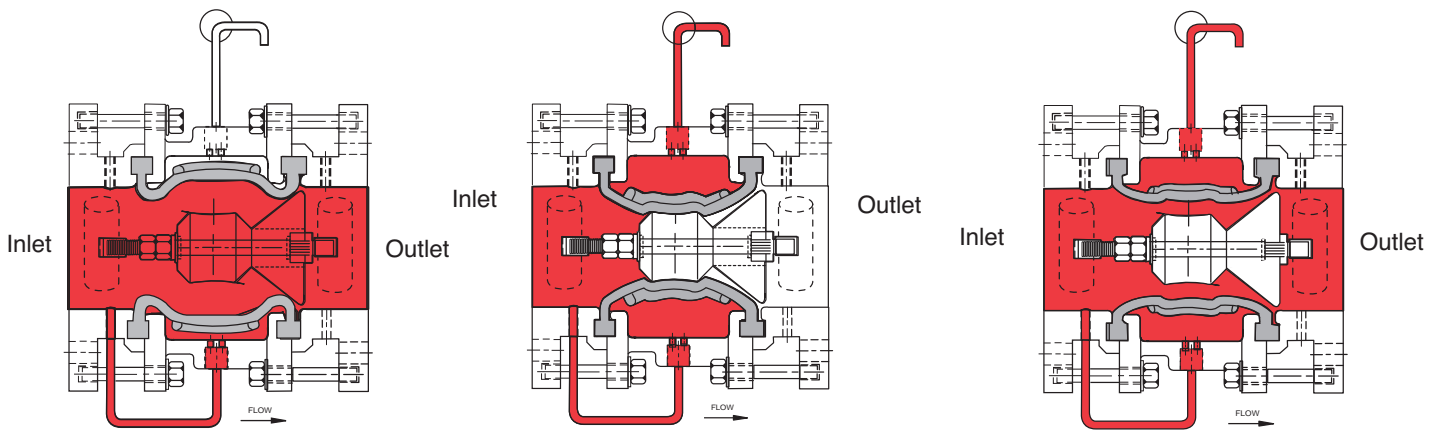

#### Full Open Operation

The valve opens when pilot set pressure is reached and pressure in the control chamber is relieved.

#### Tight Closing Operation

Water pressure (equal to inlet pressure) from valve inlet or from upstream of valve is applied to the control chamber. Valve closes bubble tight.

#### Modulating Action

The valve tube diaphragm holds any intermediate position when a quantity of water is exhausted from the control chamber via the pilot. The quantity of water in the control chamber is established by the “set pressure” of the pilot.

The control chamber is filled or exhausted to atmosphere, maintaining “set pressure.”

## Dimensions

## Model 850-20

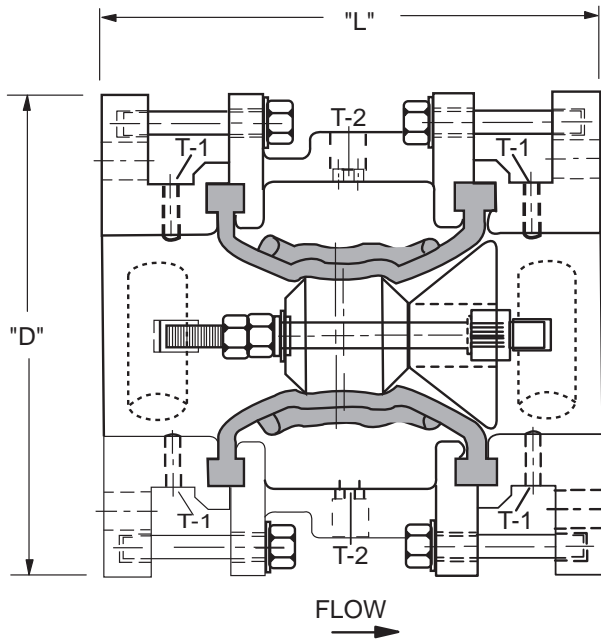

Valve Size (Inches)	3	4	6	8	10
L	8.75	9.75	10.75	11.75	14.00
D	7.5	9.5	11.75	14.00	16.44
T-1/T-2 (NPT)	1/4	1/4	3/8	3/8	1/2
Approx. Wt. (Lbs.)	67	99	135	185	270

Valve Size (mm)	80	100	150	200	250
L	222	248	273	299	356
D	191	241	299	356	418
T-1/T-2 (NPT)	1/4	1/4	3/8	3/8	1/2
Approx. Wt. (kgs.)	30	45	61	84	123

FLOW FACTORS		
SIZE (IN)	CV (gpm)	KV
3"	160	36.4
4"	340	77.3
6"	885	201
8"	1667	379
*10"	2424	550

\* CALCULATED

### Valve Capacity\*

Valve Sizes	3"	4"	6"	8"	10"
NFPA 20 Maximum Recommended GPM	500	1000	2500	5000	11000

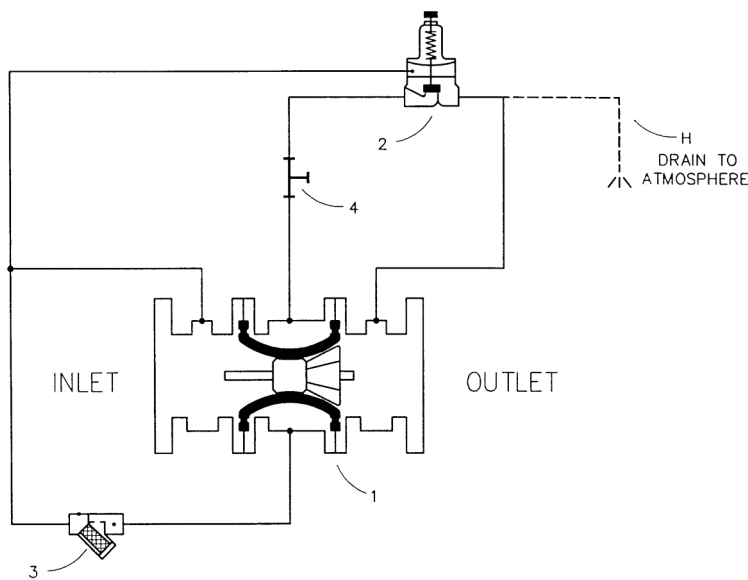

## 850-20 Basic Components

### Item Description

- 1 100-43 TDV Main Valve
- 2 CRL Pressure Relief Control
- 3 X44A Strainer and Orifice Assembly
- 4 4" Gauge Connection

Cla-Val 800 Series Control Valves operate with maximum efficiency when mounted in horizontal or vertical piping. Adequate space above and around the valve for service personnel should be considered essential. A regular maintenance program should be established based on the specific application data. However, we recommend a thorough inspection be done at least once a year. Consult factory for specific recommendations.

### MAIN VALVE

Ends: Flanged ANSI B16.5 (150lb Class)  
 Body: Cast Steel (ASTM A216 WCB)  
 Tube Diaphragm: Nitrile Rubber  
 Barrier: Urethane  
 Bolts: 316 SS  
 Pressure: 250 psig (17.24 BAR)  
 Temp. Range: 32° F to 180° F  
 (0° C to 82.2° C)

### MAIN VALVE OPTIONS

Body: Nickel Aluminum Bronze (Alloy C95800) or Duplex SS (Alloy 2205)

### PILOT VALVE

All Parts: Bronze / Monel  
 O-Rings: Nitrile Rubber  
 Control: Controls Pressure

Excursions within 3% of Set Point

Spring Range: 30 to 200 PSIG  
 Operation: Normally Closed; Opens at Set Pressure; Modulates

### PILOT VALVE OPTIONS

All Wetted Parts: Monel (Alloy 400)



E-850-20 (R-3/2011)

## CLA-VAL

1701 Placentia Avenue • Costa Mesa CA 92627

800-942-6326 • Fax: 949-548-5441 • Web Site: [cla-val.com](http://cla-val.com) • E-mail: [info@cla-val.com](mailto:info@cla-val.com)

### CLA-VAL CANADA

4687 Christie Drive  
 Beamsville, Ontario  
 Canada L0R 1B4  
 Phone: 905-563-4963  
 Fax: 905-563-4040  
 E-mail: [sales@cla-val.ca](mailto:sales@cla-val.ca)

### CLA-VAL EUROPE

Chemin des Mésanges 1  
 CH-1032 Romanel/  
 Lausanne, Switzerland  
 Phone: 41-21-643-15-55  
 Fax: 41-21-643-15-50  
 E-mail: [cla-val@cla-val.ch](mailto:cla-val@cla-val.ch)

### CLA-VAL UK

Dainton House, Goods Station Road  
 Tunbridge Wells  
 Kent TN11 2 DH England  
 Phone: 44-1892-514-400  
 Fax: 44-1892-543-423  
 E-mail: [info@cla-val.co.uk](mailto:info@cla-val.co.uk)

### CLA-VAL FRANCE

Porte du Grand Lyon 1  
 ZAC du Champ du Périer  
 France - 01700 Neyron  
 Phone: 33-4-72-25-92-93  
 Fax: 33-4-72-25-04-17  
 E-mail: [cla-val@cla-val.fr](mailto:cla-val@cla-val.fr)

### CLA-VAL PACIFIC

45 Kennaway Road  
 Woolston, Christchurch, 8023  
 New Zealand  
 Phone: 64-39644860  
 www.cla-valpacific.com  
 E-mail: [info@cla-valpacific.com](mailto:info@cla-valpacific.com)

©COPYRIGHT CLA-VAL 2018 Printed in USA Specifications subject to change without notice.



# MODELS 90G-21 and 90G-21P 90A-21 and 90A-21P

## Fire Protection Pressure Reducing Valves



90-21P UL Listed Fire Protection Pressure Reducing Valve with Gauges



- **UL Listed, ULC Listed, MEA Approved**
- **Globe or Angle Pattern**
- **Proven Reliable Design**
- **Available in Cast Bronze, Ductile Iron and Cast Steel**
- **Accurate Pressure Control**
- **In Line Service**
- **Grooved Ends (1 1/2" - 8")**



90-21 UL Listed Grooved End Fire Protection Pressure Reducing Valve



**MEA Approved**

Cla-Val 90-21 and 90-21P Pressure Reducing Valves are indispensable in any fire protection system. Available in globe (90G-21/90G-21P) and angle patterns (90A-21 and 90A-21P), our diaphragm actuated design is proven to be highly reliable and easy to maintain. Globe and angle pattern valves feature a full range of adjustments. These valves are also available in a variety of material options. Epoxy coating is strongly recommended for all fire system valves (excluding bronze valves). All configurations of the valve can be supplied with optional internal and external epoxy coating of the main valve wetted surfaces.

Special System Water Control Valves – Class II  
UL Product Category VLMT – File No. Ex 2534

### Function

Cla-Val 90G-21 (globe) and 90A-21 (angle) Pressure Reducing Valves automatically reduce a higher inlet pressure to a steady lower outlet pressure regardless of changing flow rate and/or varying inlet pressure. The valves pilot control system is very sensitive to slight downstream pressure fluctuations, and will automatically open or close to maintain the desired pressure setting. The downstream pressure can be set over a wide range by turning the adjustment screw on the CRD pilot control. The adjustment screw is protected by a screw-on cover, which can be sealed to discourage tampering.

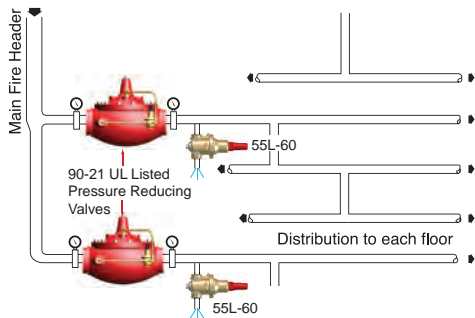

### Schematic Diagram

- | Item | Description                              |
|------|--|
| 1    | 100KX Hytrol Main Valve                  |
| 2    | X58C Restriction Assembly                |
| 3    | CRD Pressure Reducing Control (see note) |
| 4    | X46A Flow Clean Strainer                 |
| P    | Gauge Option                             |

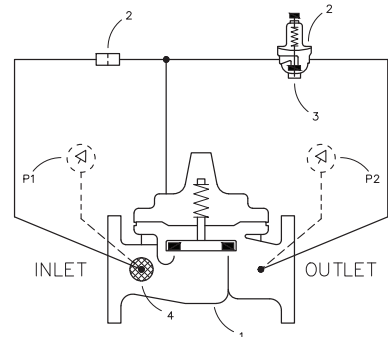

#### Note:

For Steel and Ductile Iron 300 Class Valves, use CRDKX with a special diaphragm washer, yoke and screws (30- 165)

### Typical Application

Underwriters Laboratories requires the installation of pressure gauges upstream and downstream of the Pressure Reducing Valve.

A relief valve of not less than 1/2 inch in size must also be installed on the downstream side of the pressure control valve. Adequate drainage for the relief valve discharge must be provided.

The valve made be installed in either vertical or horizontal positions.

### UL / ULC Listings

Size	Ductile Iron 150# Flanged	Ductile Iron 300# Screwed	Ductile Iron 300 # Flanged	Bronze 300# Threaded	Bronze 150# Flanged	Bronze 300# Flanged	Cast Steel 300# Flanged Grooved End	Globe Pattern Ductile Iron Grooved End	Angle Pattern Ductile Iron Grooved End
1 1/2"	UL / ULC	UL / ULC	UL / ULC	UL / ULC			UL / ULC	UL / ULC	
2"	UL / ULC	UL / ULC	UL / ULC	UL / ULC	ULC	ULC	UL / ULC	UL / ULC	UL / ULC
2 1/2"	UL / ULC	UL / ULC	UL / ULC	UL / ULC	ULC	ULC	UL / ULC	UL	
3"	UL / ULC	UL / ULC	UL / ULC	UL / ULC	ULC	ULC	UL / ULC	UL / ULC	UL / ULC
4"	UL / ULC		UL / ULC		ULC	ULC	UL / ULC	UL / ULC	UL / ULC
6"	UL / ULC		UL / ULC				UL / ULC	UL / ULC	UL / ULC
8"	UL / ULC		UL / ULC					UL / ULC	
10"	ULC		ULC						

## Dimensions

Valve Size (Inches)	1 1/2	2	2 1/2	3	4	6	8	10
A Threaded	7.25	9.38	11.00	12.50	—	—	—	—
AA 150 ANSI	8.50	9.38	11.00	12.00	15.00	20.00	25.38	29.75
AAA 300 ANSI	9.00	10.00	11.62	13.25	15.62	21.00	26.38	31.12
AAAA Grooved End	8.50	9.00	11.00	12.50	15.00	20.00	25.38	—
B	1.12	1.50	1.69	2.56	3.19	4.31	5.31	9.25
BB Grooved End	2.00	2.50	2.88	3.12	4.25	6.00	7.56	—
C Max.	5.50	6.50	7.56	8.19	10.62	13.38	16.00	17.12
CC Max. Grooved End	4.10	5.00	6.88	6.50	8.80	11.10	14.50	—
D	2.81	3.31	4.40	4.56	5.75	7.88	10.00	11.81
DD Grooved End	2.81	3.31	4.40	4.56	5.75	7.88	10.00	—
E Threaded	3.25	4.75	5.50	6.25	—	—	—	—
EE 150 ANSI	4.00	4.75	5.50	6.00	7.50	10.00	12.75	14.88
EEE 300 ANSI	4.25	5.00	5.88	6.38	7.88	10.50	13.25	15.56
EEEE Grooved End	—	4.75	—	6.00	7.50	—	—	—
F Threaded	1.88	3.25	4.00	4.50	—	—	—	—
FF 150 ANSI	4.00	3.25	4.00	4.00	5.00	6.00	8.00	8.62
FFF 300 ANSI	4.25	3.50	4.31	4.38	5.31	6.50	8.50	9.31
FFFF Grooved End	—	3.25	—	4.50	5.00	—	—	—
G (Max)	7.50	7.75	7.75	8.00	9.00	9.50	10.50	11.50
GG (Max)	8.10	8.00	—	8.13	9.31	10.50	11.50	—

Valve Size (mm)	40	50	65	80	100	150	200	250
A Threaded	184	238	279	318	—	—	—	—
AA 150 ANSI	216	238	279	305	381	508	645	756
AAA 300 ANSI	229	254	295	337	397	533	670	790
AAAA Grooved End	216	228	279	318	381	508	645	—
B	28	38	43	65	81	109	135	235
BB Grooved End	52	54	64	79	105	152	184	—
C Max.	140	161	192	208	270	340	406	435
CC Max. Grooved End	104	127	175	165	223	281	369	—
D	71	84	102	116	146	200	254	—
DD Grooved End	71	84	102	116	146	200	254	—
E Threaded	83	121	140	159	—	—	—	—
EE 150 ANSI	102	121	140	152	191	254	324	378
EEE 300 ANSI	108	127	149	162	200	267	349	395
EEEE Grooved End	—	121	—	152	191	—	—	—
F Threaded	48	83	102	114	—	—	—	—
FF 150 ANSI	102	83	102	102	127	152	203	217
FFF 300 ANSI	108	89	109	111	135	165	216	236
FFFF Grooved End	—	121	—	114	127	—	—	—
G (Max)	191	197	197	203	228	241	267	292
GG (Max)	206	203	—	207	236	267	292	—

## Selection Guidelines

### Flow Capacity Table

Flow Rate (GPM of Water)

Valve Size	Maximum	Minimum
1 1/2"	160	1
2"	262	1
2 1/2"	373	2
3"	576	2
4"	992	4
6"	2251	10
8"	3900	15
10"	6150	35

### Optional UL Listed Materials for Seawater and Severe Service Applications:

- Nickel Aluminum Bronze (NAB) - ASTM B148 Alloy C95800
- Monel - QQ-N-288 Comp B - ASTM A494 Grade M30H
- Cast Steel - ASTM A216 Grade WCB
- 316 Stainless Steel - ASTM A743 Grades CF3M and CFM8
- Super Austenitic Stainless Steel - ASTM A351 Grade CK3MCuN (SMO 254)
- Super Duplex Stainless Steel - ASTM A890 Grade 5A (CE3MN)

Note: The Actual Capacity is limited by available DP.

SPECIAL NOTE: THE MODEL 90-21/90-21P CAN BE SUPPLIED WITH INTERNAL EPOXY COATING OF THE MAIN VALVE. THIS OPTION IS U.L. FILE NO. EX2855, C.C. NO. HNF3 EPOXY COATING IS STRONGLY RECOMMENDED FOR ALL CAST VALVES.



E-90-21/90-21P (R-09/2016)

## CLA-VAL

1701 Placentia Avenue • Costa Mesa, CA 92627 • Phone: 949-722-4800  
 Fax: 949-548-5441 • Web Site: cla-val.com • E-mail: claval@cla-val.com

### CLA-VAL CANADA

4687 Christie Drive  
 Beamsville, Ontario  
 Canada L0R 1B4  
 Phone: 905-563-4963  
 Fax: 905-563-4040  
 E-Mail: sales@cla-val.ca

### CLA-VAL EUROPE

Chemin des Mésanges 1  
 CH-1032 Romanel/  
 Lausanne, Switzerland  
 Phone: 41-21-643-15-55  
 Fax: 41-21-643-15-50  
 E-Mail: cla-val@cla-val.ch

### CLA-VAL UK

Dainton House, Goods Station Road  
 GB - Tunbridge Wells  
 Kent TN11 2 DH England  
 Phone: 44-1892-514-400  
 Fax: 44-1892-543-423  
 E-Mail: info@cla-val.co.uk

©Copyright CLA-VAL 2017 Printed in USA Specifications subject to change without notice.

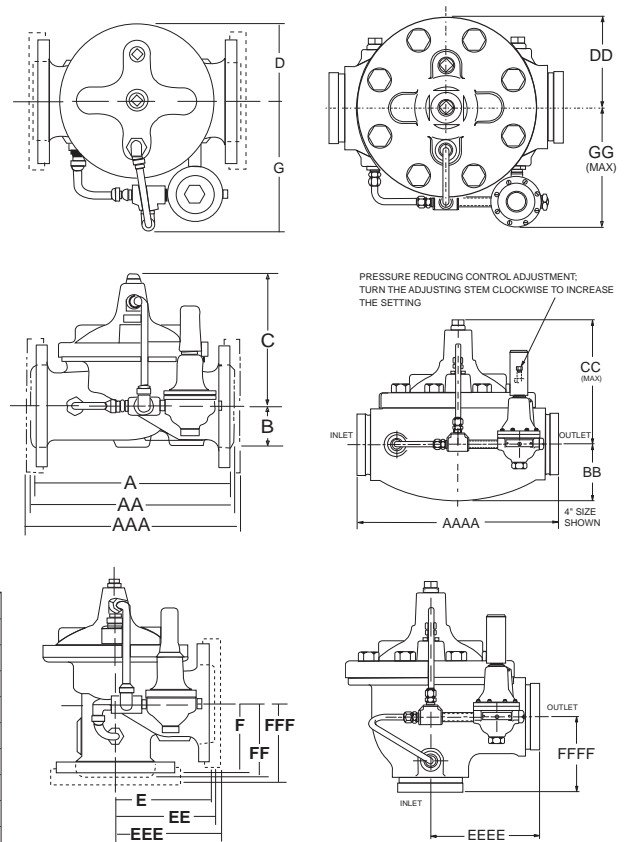

**Sizes** See chart on first page.

**End Details** 150 and 300 ANSI B16.42

**Pressure Ratings** Class 150 - 250 psi Max.  
 Class 300 - 400 psi Max

Water, to 180°F Max.

**Standard Main Valve Body & Cover**

Ductile Iron ASTM A536 Grade 65-45-12

**Standard Main Valve Trim:**

Bronze Seat

Stainless Steel Stem

**Standard Pilot Control System:**

Cast Bronze with Stainless Steel Trim

Pressure Adjustment Range	Class	UL	ULC
	175 lb.	30-165	30-300
	300 lb.	30-165	30-300

**Pressure Differential** 10 PSI Minimum

**Temperature Range** Water to 180°F Maximum

## When Ordering Please Specify

1. Model Number 90-21 or 90-21P
2. Size
3. Globe or Angle Pattern
4. Main Valve Body and Cover Material
5. Threaded, Flanged or Grooved
6. Pressure Class
7. Optional Epoxy Coating (specify w/suffix KC)



— MODEL —

# 90-FS-PRV-15

## Factory Set (1-1/2-inch) Pressure Reducing Valve



- Sensitive and Accurate Pressure Control
- Complies with NFPA for Class II Systems
- UL/ ULC Listed

The Cla-Val 1 1/2" Model 90-FS-PRV Is a UL/ULC listed Factory Set pressure reducing valve which can be used as a standpipe valve, floor control valve and a checking device.

The valve is in compliance with NFPA for Class II systems and can handle "Flow" and "No Flow" conditions and rated for systems up to a maximum inlet 300 psi.

A brass body is standard but can be supplied with a chrome plate finish. An optional Supervisory Switch is available at an additional charge.



### End Connection Options

- Female NPT x Female NPT- (FF)
- Groove x Groove - Angle - (GG)
- Groove x Male Outlet - (GM)

*When protecting life  
and property, count on Cla-Val*

The Cla-Val Company Valve Selection and Sizing Program is available upon request



MODEL

# 90-FS-PRV-25

## Factory Set (2-1/2-inch) Pressure Reducing Valve



- Sensitive and Accurate Pressure Control
- Complies with NFPA for Class I Systems
- UL/ ULC Listed

The Cla-Val 2 1/2" Model 90-FS-PRV Is a UL/ULC listed Factory Set pressure reducing valve which can be used as a standpipe valve, floor control valve and a checking device.

The valve is in compliance with NFPA for Class I systems and can handle "Flow" and "No Flow" conditions and rated for systems up to a maximum inlet pressure of 400 psi.

A brass body is standard but can be supplied with a chrome plate finish. An optional Supervisory Switch is available at an additional charge.



### End Connection Options

- Female NPT x Male Hose - Angle - (FM)
- Female NPT x Female NPT- Straight - (SF)
- Groove x Groove - Angle - (GG)
- Groove x Groove -Straight -(SG)
- Groove x Male Outlet -Angle - (GM)

*When protecting life  
and property, count on Cla-Val*

The Cla-Val Company Valve Selection and Sizing Program is available upon request



# MODEL 90-PRV-175-15

## Pressure Restricting Valve



- Sensitive and Accurate Pressure Restriction
- Easy Adjustment and Maintenance
- UL/ ULC Listed
- FM Approved

The Cla-Val 1 1/2" Model 90-PRV-175-15 features a Cast Brass finish body with Forgeline Bonnet and Seat Assembly. The system water pressure is controlled by adjusting the flow restriction, however, is full flow is required the restriction can be overridden.

This heavy duty design is factory tested to 300 psi (2070 KPa). It is also UL/ULC Listed and FM approved.

A brass body is standard but can be supplied with a polish chrome, cast chrome or polish brass finish.



### End Connection Options

- Female NPT x Male Hose (Angle)-FM
- Female NPT x Female NPT
- Groove X Male Outlet

*When protecting life  
and property, count on Cla-Val*

### Standards

#### NFPA 14

- 100 psi max. outlet
- 175 psi max. inlet



# MODEL — 90-PRV-175-25

## Pressure Restricting Valve



- Sensitive and Accurate Pressure Restriction
- Easy Adjustment and Maintenance
- UL/ ULC Listed
- FM Approved

The Cla-Val 2 ½” Model 90-PRV-175-25 features a Cast Brass finish body with Forgeline Bonnet and Seat Assembly. The system water pressure is controlled by adjusting the flow restriction, however is full flow is required the restriction can be overridden.

This heavy duty design is factory tested to 300 psi (2070 KPa). It is also UL/ULC Listed and FM approved.

A brass body is standard but can be supplied with a polish chrome, cast chrome or polish brass finish.



### End Connection Options

- Female NPT x Male Hose (Angle)-FM
- Female NPT x Female NPT
- Groove X Male Outlet

### Standards

#### NFPA 14

- 175 psi max. outlet
- 125 psi max. inlet

*When protecting life  
and property, count on Cla-Val*



— **MODEL** — **HV-100-15**

## Angle Hose Valve



- Sensitive and Accurate Performance
- UL/ ULC Listed
- FM Approved

The Cla-Val 1 ½” Model HV-100-15 features a Cast Brass finish body with Forgeline Bonnet and Seat Assembly.

This heavy duty design is factory tested to 300 psi (2070 KPa). It is also UL/ULC Listed and FM approved.

A brass body is standard but can be supplied with a polish chrome, cast chrome or polish brass finish.



### End Connection Options

- Female NPT x Male Hose (Angle)-FM
- Female NPT x Female NPT

### Standards

#### NFPA 14

- 100 psi max.
- 100 gpm max.

*When protecting life  
and property, count on Cla-Val*



# — MODEL — HV-100-25

## Angle Hose Valve



- Sensitive and Accurate Performance
- UL/ ULC Listed
- FM Approved

The Cla-Val 2 ½” Model HV-100-25 features a Cast Brass finish body with Forgeline Bonnet and Seat Assembly.

This heavy duty design is factory tested to 300 psi (2070 KPa). It is also UL/ULC Listed and FM approved. Please specify regional hose thread for outlet as shown below.

A brass body is standard but can be supplied with a polish chrome, cast chrome or polish brass finish.

### Available hose threads include:

BCT, CSA, NSST, NPSH, NST, QST, WCT, Louisville, Cleveland, Chicago, Pittsburg, New Cincinnati, New York Corp, New York Fire Department, Richmond, and Raleigh



### End Connection Options

- Female NPT x Male Hose (Angle)-FM
- Female NPT x Female NPT
- Groove X Male Outlet

### Standard

#### NFPA 14

- 175 psi max.
- 250 gpm max.
- Fire Department - 100 psi min.

*When protecting life  
and property, count on Cla-Val*

# 90-42 — MODEL —

## Seawater Service Pressure Reducing Valve

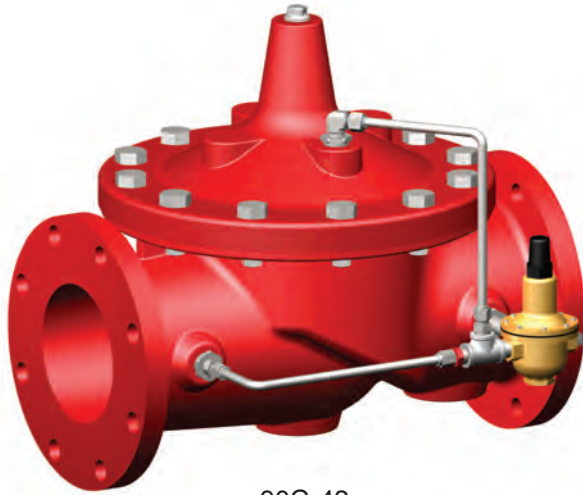

90G-42  
Globe Pattern



- Globe or Angle Pattern
- Proven Reliable Design
- Available in Cast Bronze, Iron and Steel
- Accurate Pressure Control
- In Line Service

Cla-Val 90G-42 (globe) and 90A-42 (angle) Pressure Reducing Valves are indispensable in any fire protection system. Our diaphragm actuated design is proven highly reliable and easy to maintain. We offer both a globe or angle pattern with a full range of adjustments. These valves are available in cast bronze, iron or steel and all special alloy.

Epoxy coating for all system valves are supplied with internal and external epoxy coating of the main valve wetted surfaces, for ductile iron and cast steel only.

If UL Listed is required for Model 90-42 Seawater Service use Model 90-21KX when ordering. UL Listed sizes limited to 1 1/2" - 8" sizes.

### Function

Cla-Val Model 90G-42 (globe) and 90A-42 (angle) Seawater Service Pressure Reducing Valves automatically reduce a higher inlet pressure to a steady lower outlet pressure regardless of changing flow rate and/or varying inlet pressure. The valves pilot control system is very sensitive to slight downstream pressure fluctuations, and will automatically open or close to maintain the desired pressure setting. The downstream pressure can be set over a wide range by turning the adjustment screw on the CRD pilot control. The adjustment screw is protected by a screw-on cover, which can be sealed to discourage tampering.

### Schematic Diagram

- | Item | Description                              |
|------|--|
| 1    | Model 100S/2100S Hytrol (Globe or Angle) |
| 2    | X58C Restriction Tube Fitting            |
| 3    | CRD Pressure Reducing Control            |
| 4    | X46A Flow Clean Strainer                 |

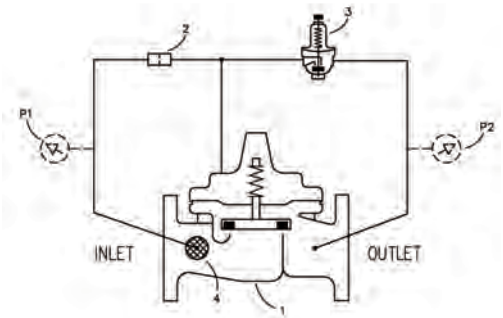

**Sizes:** Threaded Ends: 1 1/2" - 3"  
Globe Flanged: 2" - 36"  
Angle Flanged: 2" - 16"

**End Details:** Cast Steel ANSI B16.5  
Bronze ANSI B16.24  
Stainless Steel ANSI B16.5  
Ductile Iron ANSI B16.42

**Pressure Ratings:** 150 Class 250 psi Max.  
300 Class 400 psi Max.

### Temperature

**Range:** Water 180°F Max.

**Materials:** **Main valve body & cover**  
Ductile Iron ASTM A-536\*  
Cast Steel ASTM A216-WCB\*  
Naval Bronze ASTM B61  
Stainless Steel ASTM A743-CF-8M  
Ni. AL. Bronze ASTM B148  
Super Duplex SST  
Monel QQ-N-281 Class B  
**Main valve trim:**  
ASTM B61 Bronze Seat,  
Monel Trim

### Pilot control system:

Cast Bronze with Monel Trim  
Monel, Super Duplex Stainless Steel optional  
Stainless Steel 316 Tubing & Fittings

**Adjustment Ranges:** 15 - 75 psi  
30 - 300 psi

Main Valve and pilot valve diaphragm and disc:  
Burna-N® synthetic rubber

\*The 90G-42 (globe) and 90A-42 (angle) in cast steel are supplied with standard internal and external epoxy coating

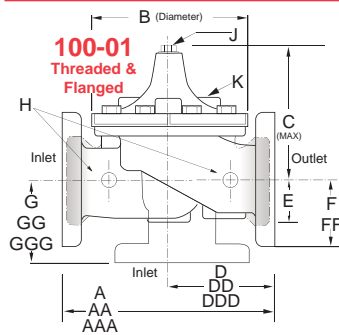

### Model 90-42 Dimensions

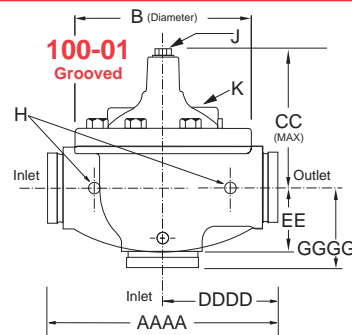
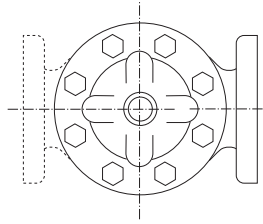

### When Ordering Please Specify

1. Model No. 90-42
2. Size
3. Globe or Angle
4. Main Valve Body and Cover Material
5. Threaded, Flanged or Grooved
6. Pressure Class
7. Adjustment Range

Valve Size (Inches)	1	1 1/4	1 1/2	2	2 1/2	3	4	6	8	10	12	14	16	18	20	24	30	36
A Threaded	7.25	7.25	7.25	9.38	11.00	12.50	—	—	—	—	—	—	—	—	—	—	—	—
AA 150 ANSI	7.50	8.00	8.50	9.38	11.00	12.00	15.00	20.00	25.38	29.75	34.00	39.00	41.38	46.00	52.00	61.50	63.00	76.00
AAA 300 ANSI	—	—	9.00	10.00	11.62	13.25	15.62	21.00	26.38	31.12	35.50	40.50	43.50	47.64	53.62	63.24	64.50	76.00
AAAA Grooved End	—	—	8.50	9.00	11.00	12.50	15.00	20.00	25.38	—	—	—	—	—	—	—	—	—
B Dia.	5.62	5.62	5.62	6.62	8.00	9.12	11.50	15.75	20.00	23.62	28.00	32.75	35.50	41.50	45.00	53.16	56.00	66.00
C Max.	5.50	5.50	5.50	6.50	7.56	8.19	10.62	13.38	16.00	17.12	20.88	24.19	25.00	39.06	41.90	43.93	54.60	61.50
CC Max. Grooved End	—	—	4.75	5.75	6.88	7.25	9.31	12.12	14.62	—	—	—	—	—	—	—	—	—
D Threaded	3.25	3.25	3.25	4.75	5.50	6.25	—	—	—	—	—	—	—	—	—	—	—	—
DD 150 ANSI	—	—	4.00	4.75	5.50	6.00	7.50	10.00	12.69	14.88	17.00	19.50	20.81	—	—	30.75	—	—
DDD 300 ANSI	—	—	4.25	5.00	5.88	6.38	7.88	10.50	13.25	15.56	17.75	20.25	21.62	—	—	31.62	—	—
DDDD Grooved End	—	—	—	4.75	—	6.00	7.50	—	—	—	—	—	—	—	—	—	—	—
E	1.12	1.12	1.12	1.50	1.69	2.06	3.19	4.31	5.31	9.25	10.75	12.62	15.50	12.95	15.00	17.75	21.31	24.56
EE Grooved End	—	—	2.00	2.50	2.88	3.12	4.25	6.00	7.56	—	—	—	—	—	—	—	—	—
F 150 ANSI	2.12	2.25	2.50	3.00	3.50	3.75	4.50	5.50	6.75	8.00	9.50	10.50	11.75	15.00	16.50	19.25	22.50	25.60
FF 300 ANSI	—	—	3.06	3.25	3.75	4.13	5.00	6.25	7.50	8.75	10.25	11.50	12.75	15.00	16.50	19.25	24.00	25.60
G Threaded	1.88	1.88	1.88	3.25	4.00	4.50	—	—	—	—	—	—	—	—	—	—	—	—
GG 150 ANSI	—	—	4.00	3.25	4.00	4.00	5.00	6.00	8.00	8.62	13.75	14.88	15.69	—	—	22.06	—	—
GGG 300 ANSI	—	—	4.25	3.50	4.31	4.38	5.31	6.50	8.50	9.31	14.50	15.62	16.50	—	—	22.90	—	—
GGGG Grooved End	—	—	—	3.25	—	4.25	5.00	—	—	—	—	—	—	—	—	—	—	—
H NPT Body Tapping	.375	.375	.375	.375	.50	.50	.75	.75	1	1	1	1	1	1	1	1	2	2
J NPT Cover Center Plug	.25	.25	.25	.50	.50	.50	.75	.75	1	1	1.25	1.5	2	1.5	1.5	1.5	2	2
K NPT Cover Tapping	.375	.375	.375	.375	.50	.50	.75	.75	1	1	1	1	1	1	1	1	2	2
Stem Travel	0.4	0.4	0.4	0.6	0.7	0.8	1.1	1.7	2.3	2.8	3.4	4.0	4.5	5.1	5.63	6.75	7.5	8.5
Approx. Ship Wt. Lbs.	15	15	15	35	50	70	140	285	500	780	1165	1600	2265	2982	3900	6200	7703	11720
Valve Size (mm)	25	32	40	50	65	80	100	150	200	250	300	350	400	450	500	600	750	900
A Threaded	184	184	184	238	279	318	—	—	—	—	—	—	—	—	—	—	—	—
AA 150 ANSI	191	203	216	238	279	305	381	508	645	756	864	991	1051	1168	1321	1562	1600	1930
AAA 300 ANSI	—	—	229	254	295	337	397	533	670	790	902	1029	1105	1210	1362	1606	1638	1930
AAAA Grooved End	—	—	216	228	279	318	381	508	645	—	—	—	—	—	—	—	—	—
B Dia.	143	143	143	168	203	232	292	400	508	600	711	832	902	1054	1143	1350	1422	1676
C Max.	140	140	140	165	192	208	270	340	406	435	530	614	635	992	1064	1116	1387	1562
CC Max. Grooved End	—	—	120	120	146	175	184	236	308	371	—	—	—	—	—	—	—	—
D Threaded	83	83	83	121	140	159	—	—	—	—	—	—	—	—	—	—	—	—
DD 150 ANSI	—	—	102	121	140	152	191	254	322	378	432	495	528	—	—	781	—	—
DDD 300 ANSI	—	—	108	127	149	162	200	267	337	395	451	514	549	—	—	803	—	—
DDDD Grooved End	—	—	—	121	—	152	191	—	—	—	—	—	—	—	—	—	—	—
E	29	29	29	38	43	52	81	110	135	235	273	321	394	329	381	451	541	624
EE Grooved End	—	—	52	64	73	79	108	152	192	—	—	—	—	—	—	—	—	—
F 150 ANSI	54	57	64	76	89	95	114	140	171	203	241	267	298	381	419	489	572	650
FF 300 ANSI	—	—	78	83	95	105	127	159	191	222	260	292	324	381	419	489	610	650
G Threaded	48	48	48	83	102	114	—	—	—	—	—	—	—	—	—	—	—	—
GG 150 ANSI	—	—	102	83	102	102	127	152	203	219	349	378	399	—	—	560	—	—
GGG 300 ANSI	—	—	102	89	110	111	135	165	216	236	368	397	419	—	—	582	—	—
GGGG Grooved End	—	—	—	83	—	108	127	—	—	—	—	—	—	—	—	—	—	—
H NPT Body Tapping	.375	.375	.375	.375	.50	.50	.75	.75	1	1	1	1	1	1	1	1	2	2
J NPT Cover Center Plug	.25	.25	.25	.50	.50	.50	.75	.75	1	1	1.25	1.5	2	1.5	1.5	1.5	2	2
K NPT Cover Tapping	.375	.375	.375	.375	.50	.50	.75	.75	1	1	1	1	1	1	1	1	2	2
Stem Travel	10	10	10	15	18	20	28	43	58	71	86	102	114	130	143	171	190	216
Approx. Ship Wt. Kgs.	7	7	7	16	23	32	64	129	227	354	528	726	1027	1353	1769	2812	3494	5316

Cla-Val Control Valves operate with maximum efficiency when mounted in horizontal piping with the main valve cover UP, however, other positions are acceptable. Due to component size and weight of 8 inch and larger valves, installation with cover UP is advisable. We recommend isolation valves be installed on inlet and outlet for maintenance. Adequate space above and around the valve for service personnel should be considered essential. A regular maintenance program should be established based on the specific application data. However, we recommend a thorough inspection be done at least once a year. Consult factory for specific recommendations.

### Selection Guidelines - Flow Capacity Table

Size	1	1 1/4	1 1/2	2	2 1/2	3	4	6	8	10	12	14	16	18	20	24	30	36
Max. Flow Rate (GPM of Water)	100	125	160	262	373	576	992	2251	3900	6150	8720	10540	13700	17500	21700	31300	48000	62500

\*For UL Listed, see Cla-Val Model 90-21 for sizes and pressure class information.



# CLA-VAL VALVES CAVITATION CHART

for water applications

### Cavitation Guide

(Applies To All Valves in This Catalog except the 100-42 Series) This chart should only be used as a guide to the proper selection of the pressure drop to be taken across Cla-Val Valves. Continued use of a valve in the shaded area of the chart could cause extensive deterioration of the valve's internals.

Consult factory for specific cavitation information.

After selecting valve size, locate inlet and outlet pressures on cavitation chart. If point located falls in shaded area, cavitation may occur.

The shaded portion of this chart is based on a cavitation index (K) of 0.5 derived from the formula  $K = \frac{P_1 - P_2}{P_v}$  where  $P_1$  = inlet pressure,  $P_2$  = outlet pressure,  $P_v$  = water vapor pressure relative to atmospheric pressure.



**ROLL SEAL (700)  
100-42  
Cavitation Zone**



**100-01/100-20  
100S/2100S  
100G/2100G  
100GS/2100GS  
Cavitation Zone**

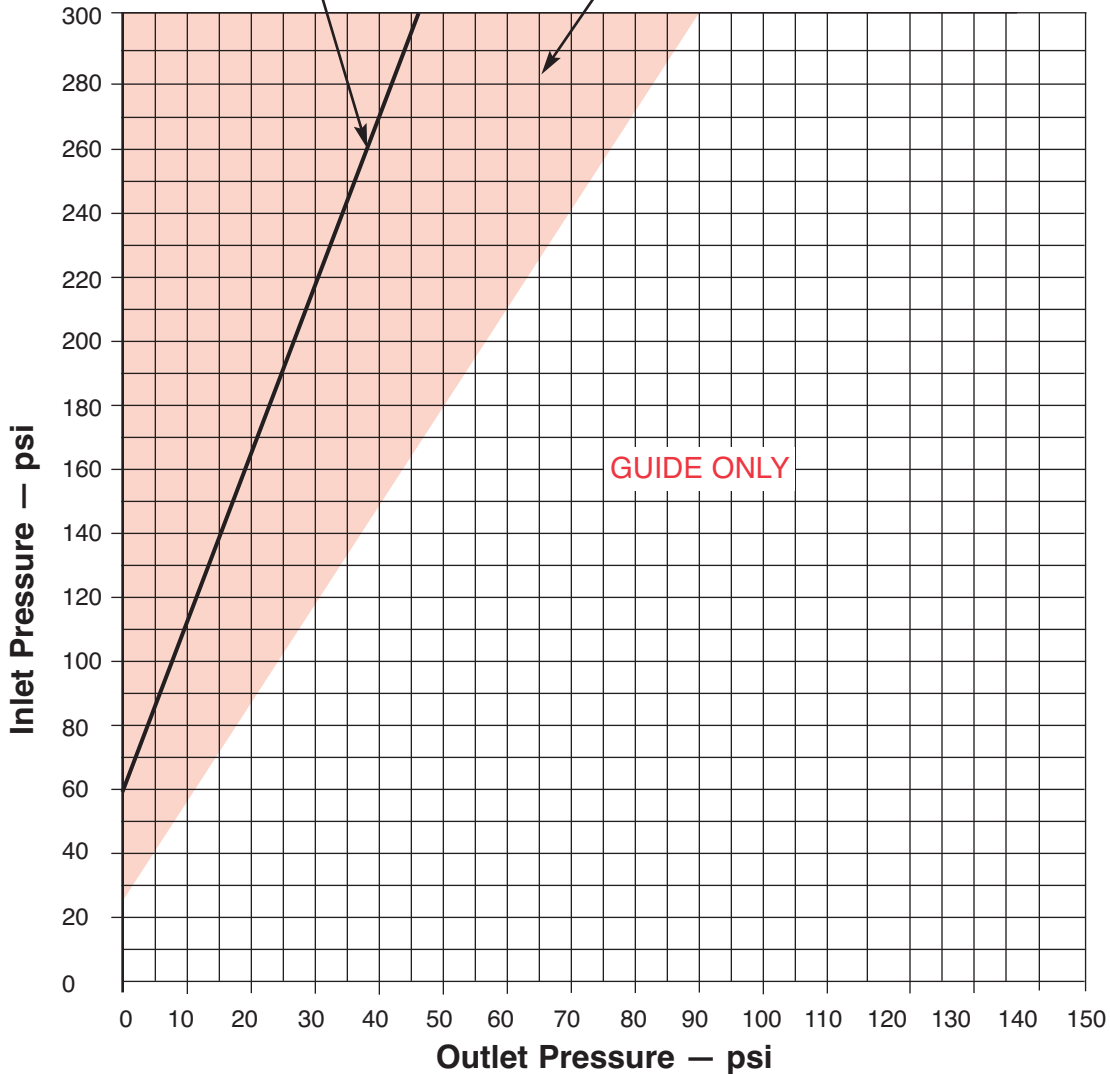



# 100S/100G/100GS/100-01 FLOW CHART



## Valve Sizing Coefficient - $C_V$

A very useful expression often used in determining the head loss and/or flow rate capacity of control valves is the  $C_V$  factor. Commonly referred to as the flow coefficient or valve sizing coefficient, this empirically determined factor describes the flow capacity of a valve.

The  $C_V$  factor is defined as the number of U.S. gallons per minute of water (at 60°F flowing temperature) discharged through a flow restriction with a head loss of one psi. In the case of a control valve, the  $C_V$  value is normally stated for the valve in the fully open position. For conditions other than full open, (i.e. modulating valves), contact Cla-Val Technical Services.

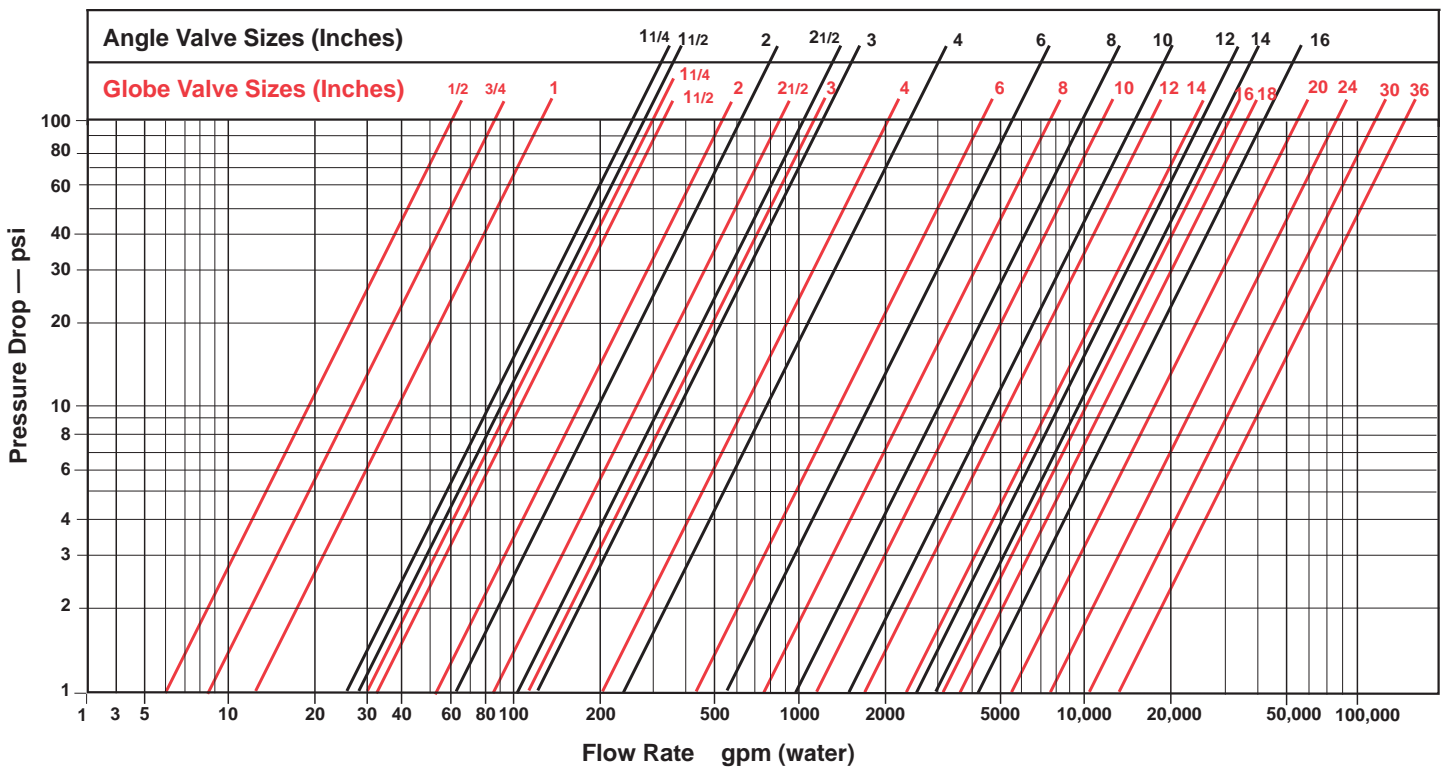

**NOTE:** The flow rate vs. head loss data presented here is based on a fully open valve condition. The maximum recommended velocity is 20 ft./sec.

## CV Factors

Valve Size	Inches	¾	½	¼	1	1¼	1½	2	2½	3	4	6	8	10	12	14	16	18	20	24	30	36	
	mm.	10	15	20	25	32	40	50	65	80	100	150	200	250	300	350	400	450	500	600	750	900	
$C_V$ Factor	Globe Pattern	Gal./Min. (gpm.)	1.8	6	8.5	13.3	30	32	54	85	115	200	440	770	1245	1725	2300	3130	3725	5345	7655	10150	14020
		Litres/Sec. (l/s.)	.43	1.44	2.04	3.2	7.2	7.7	13	20	28	48	106	185	299	414	552	752	894	1286	1837	2436	3200
	Angle Pattern	Gal./Min. (gpm.)	—	—	—	—	—	29	61	101	139	240	541	990	1575	2500*	3060*	4200*	—	—	—	—	—
		Litres/Sec. (l/s.)	—	—	—	—	—	7	15	24	33	58	130	238	378	600	734	1008	—	—	—	—	—

\*Estimated



# 100-43 (800 SERIES) FLOW CHART



## Valve Sizing Coefficient - $C_V$

A very useful expression often used in determining the head loss and/or flow rate capacity of control valves is the  $C_V$  factor. Commonly referred to as the flow coefficient or valve sizing coefficient, this empirically determined factor describes the flow capacity of a valve.

The  $C_V$  factor is defined as the number of U.S. gallons per minute of water (at 60°F flowing temperature) discharged through a flow restriction with a head loss of one psi. In the case of a control valve, the  $C_V$  value is normally stated for the valve in the fully open position. For conditions other than full open, (i.e. modulating valves), contact Cla-Val Technical Services.

3" thru 10" Tubular Diaphragm Capacity Chart

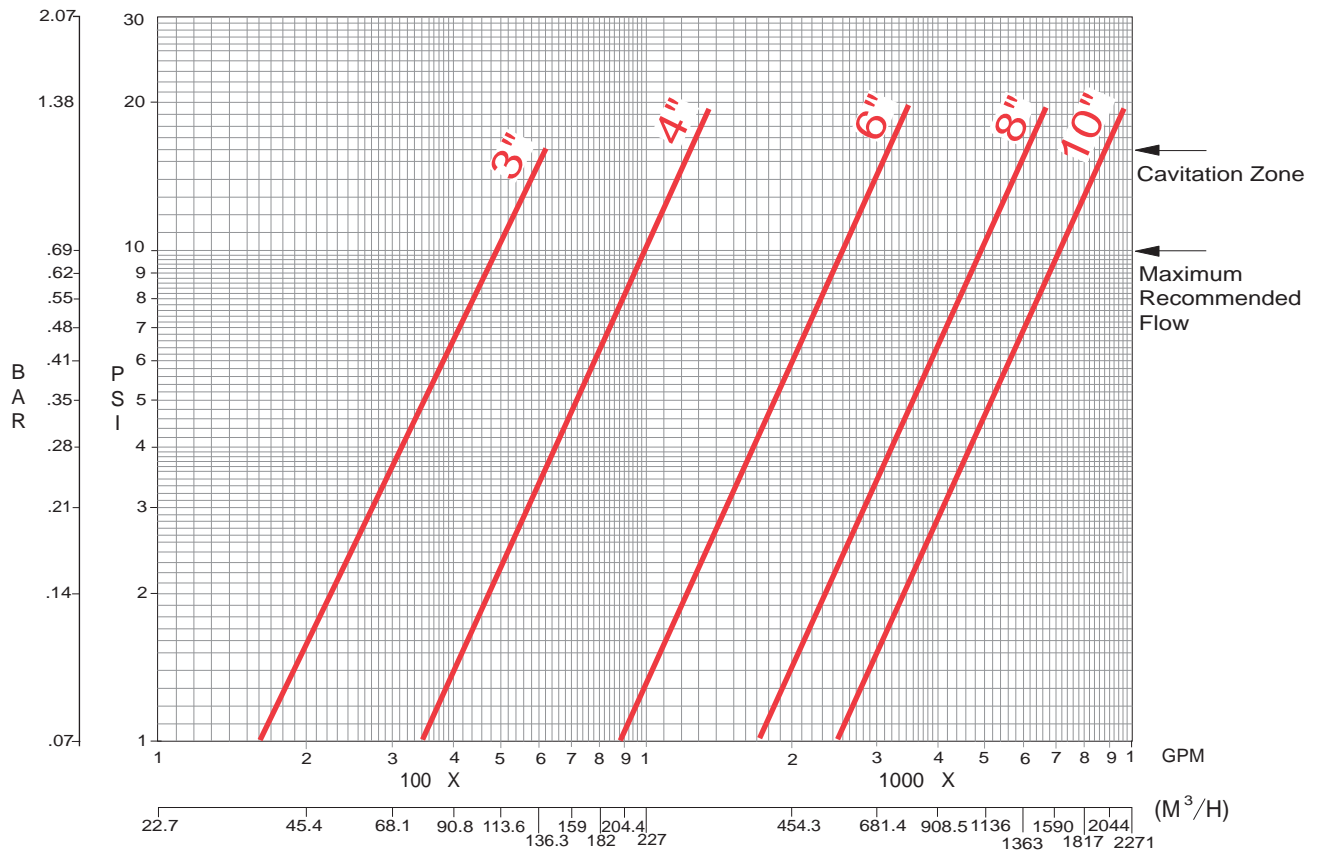

**NOTE:** The flow rate vs. head loss data presented here is based on a fully open valve condition. The maximum recommended velocity is 20 ft./sec.

## CV Factors

Valve Size	3"	4"	6"	8"	10"
$C_V$ (gpm)	160	340	885	1667	2424
$C_V$ (KV)	36.36	77.27	201.01	378.62	550

\* Calculated

# Typical Deluge Valve Applications

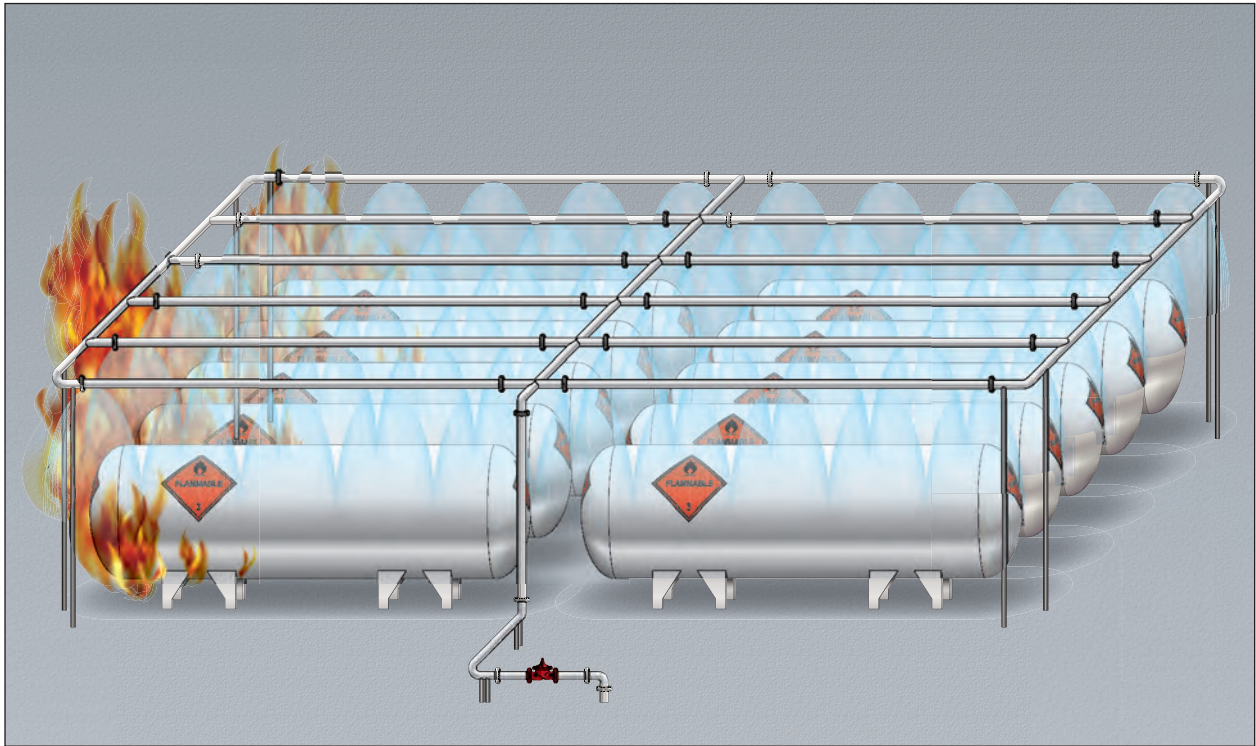

**134 Series Solenoid Operated Deluge Valve used in Water Curtain Application**

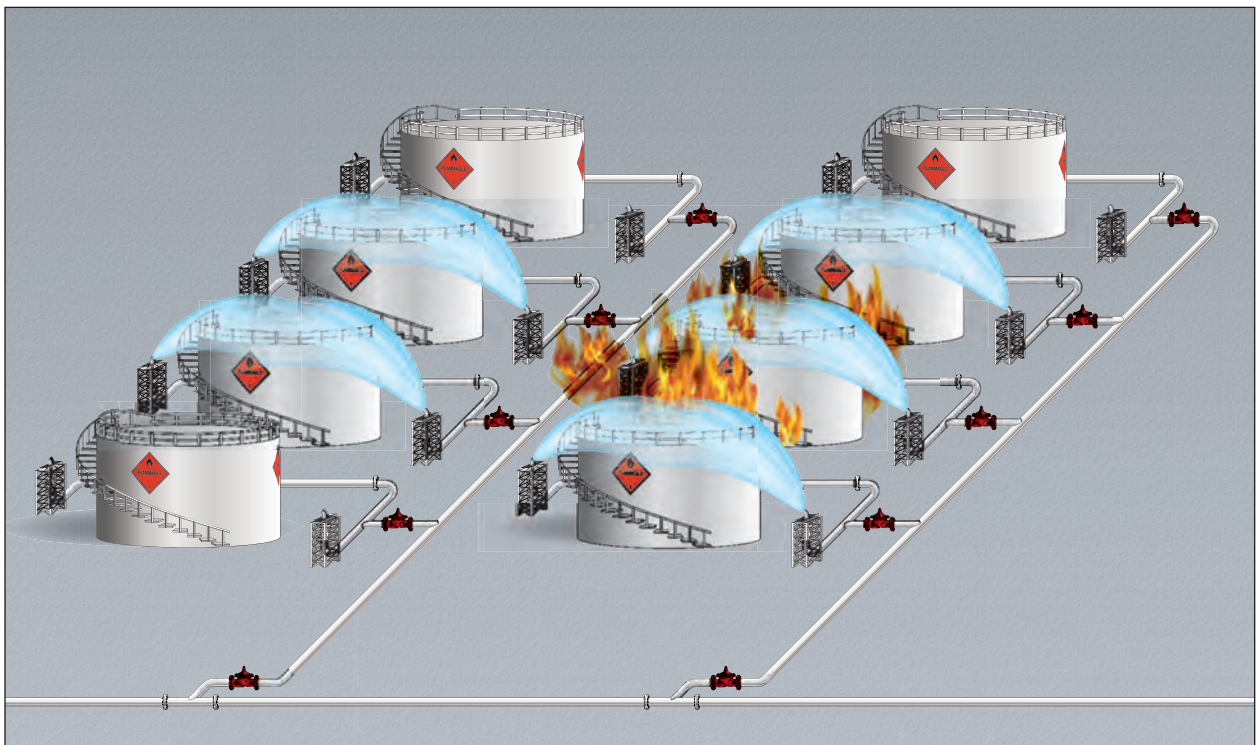

**403 Series Pneumatic Deluge Valve used in Water Cannon Application**

# 134-05 — MODEL —



## Solenoid Operated Deluge Valve



- **UL Listed / ULC Listed Main Valve 3 - 12 inch sizes**
- **Fast Acting Solenoid Control**
- **Reliable Drip Tight Shut-off**
- **Simple Design, Proven Reliable**
- **Easy Installation & Maintenance**

The Cla-Val Model 134-05 Solenoid Control Valve is an on-off control valve which either opens or closes upon receiving an electrical signal to the solenoid pilot control. This valve consists of a 100G/2100G UL/ULC Listed Hytrol Main Valve, a three-way solenoid valve and an auxiliary pilot valve. This pilot control system alternately applies pressure to/or relieves pressure from the diaphragm chamber of the main valve. It is furnished either normally open (de-energize solenoid to open) or normally closed (energize solenoid to open).

*Note: For seawater applications use 100GS/2100GS main valve*

### Schematic Diagram

Item	Description
1	100G/2100G UL/ULC Listed Hytrol Main Valve
2	CS3 Solenoid Control
3	100-01 Hytrol Pilot Valve
4	X58C Restriction Orifice
5	X46A Flow Clean Strainer

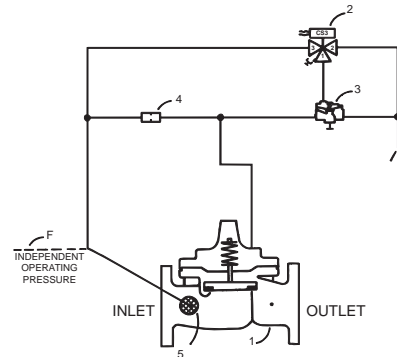

### Specifications

**SIZES** Globe: 3" - 12" flanged  
Angle: 3" - 12" flanged

**END DETAILS** Ductile Iron 150 ANSI B16.42 flanged  
Cast Steel 150 ANSI B16.5 flanged

#### PRESSURE RATINGS

150 class, 250 psi maximum (Ductile Iron)  
150 class, 285 psi maximum (All other materials)  
300 class, 300 psi maximum (All materials)

**TEMPERATURE RANGE** Water: to 180° F. Max

### Materials

#### Main valve body & cover:

Ductile Iron ASTM A-536\*  
Cast Steel ASTM A216-WCB\*  
Naval Bronze ASTM B61  
Nickel Aluminum Bronze ASTM B148  
Super Duplex Stainless Steel  
Stainless Steel ASTM A743-CF-8M

#### Main valve trim:

Bronze / Stainless Steel

#### Pilot control system:

Cast Bronze ASTM B62  
UL/ULC Listed Main Valve 3" - 12"

### Functional Data

Valve Size	Inches	3	4	6	8	10	12	
	mm	80	100	150	200	250	300	
C <sub>v</sub> Factor	<b>Globe Pattern</b>	Gal./Min. (gpm)	115	200	440	770	1245	1725
		Litres/Sec. (l/s)	27.6	48	105.6	184.8	299	414
C <sub>v</sub> Factor	<b>Angle Pattern</b>	Gal./Min. (gpm)	139	240	541	990	1575	2500*
		Litres/Sec. (l/s)	33.4	58	130	238	378	600

### Cover Capacity

Valve Size	Displacement
3"	.080 gal
4"	.169 gal
6"	.531 gal
8"	1.26 gal
10"	2.51 gal
12"	4.00 gal

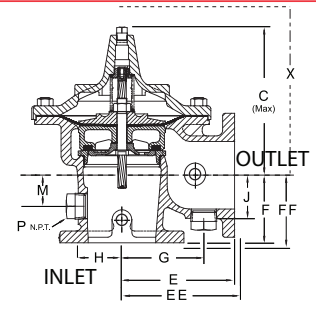
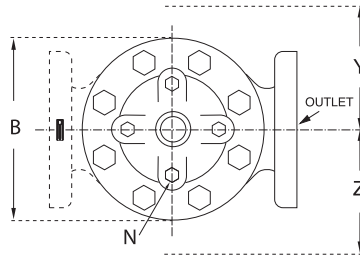
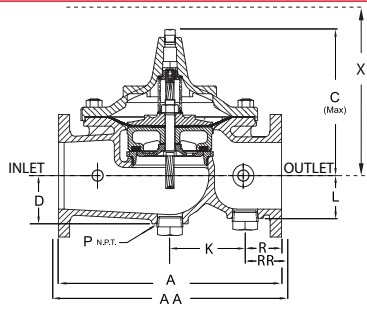

Valve Size (In.)	3	4	6	8	10	12
A 150 ANSI	12.00	15.00	20.00	25.38	29.75	—
AA 300 ANSI	13.25	15.62	21.00	26.38	31.12	34.00
B Dia.	9.12	11.50	15.75	20.00	23.62	35.50
C Max.	8.19	10.62	13.38	16.00	17.12	—
D	2.56	3.19	4.31	5.16	8.50	28.00
E 150 ANSI	7.00	8.50	10.00	12.69	14.88	20.88
EE 300 ANSI	--	8.81	10.50	13.19	--	—
F 150 ANSI	4.00	4.97	6.00	8.00	8.62	—
FF 300 ANSI	--	5.28	6.50	8.50	--	17.00
G	4.75	5.94	7.25	8.50	10.50	17.75
H	2.69	2.81	3.88	5.31	6.56	—
J	2.56	2.81	3.81	4.81	5.81	10.75
K	7.00	4.03	6.75	17.00	15.50	—
L	2.56	2.81	3.81	4.81	8.50	9.50
M	1.75	2.41	2.75	4.00	4.24	10.25
N NPT	1/2 - 14	3/4 - 14	3/4 - 14	1 - 11-1/2	1 - 11-1/2	—
P NPT	1-1/4 - 11-1/2	2 - 11-1/2				
R 150 ANSI	2.50	3.47	3.25	4.19	7.12	14.50
RR 300 ANSI	3.12	3.78	3.75	4.69	7.81	—
X Pilot System	15.00	17.00	29.00	31.00	33.00	1
Y Pilot System	11.00	12.00	20.00	22.00	24.00	1.25
Z Pilot System	11.00	12.00	20.00	22.00	24.00	1

Valve Size (mm)	80	100	150	200	250	300
A 150 ANSI	305	381	508	645	756	—
AA 300 ANSI	337	397	533	670	791	864
B Dia.	232	292	400	508	600	902
C Max.	208	270	340	406	435	—
D	65	81	110	131	216	711
E 150 ANSI	178	216	254	322	378	530
EE 300 ANSI	--	224	267	350	--	—
F 150 ANSI	102	126	152	203	219	—
FF 300 ANSI	--	134	165	216	--	432
G	121	151	184	216	267	451
H	68	71	99	135	167	—
J	65	71	97	122	148	273
K	178	102	171	432	394	—
L	65	71	97	122	216	241
M	45	61	70	102	108	260
N NPT	1/2 - 14	3/4 - 14	3/4 - 14	1 - 11 1/2	1 - 11-1/2	—
P NPT	1-1/4 - 11-1/2	2 - 11-1/2				
R 150 ANSI	64	88	83	106	181	368
RR 300 ANSI	79	96	95	119	198	—
X Pilot System	381	432	737	787	838	1
Y Pilot System	279	305	508	559	610	1.25
Z Pilot System	279	305	508	559	610	1

## Pilot System Specifications

### Temperature Range

Water: to 180°F

### Fluids

Air, water, light oils

### Rubber Parts

Buna-N® Synthetic Rubber

### Solenoid Control\*

Body:

Brass ASTM B283

Enclosure:

NEMA Type 1, 2, 3, 3S, 4, 4X general purpose watertight

NEMA Type 6, 6P, 7, 9 watertight

Explosion Proof available at extra cost

Voltages:

110, 220 - 50Hz AC

24, 120, 240, 480 - 60Hz AC

6, 12, 24, 120, 240 - DC

Others available at extra cost

Max. operating pressure differential: 200 psi

Coil:

Insulation molded Class	F
Watts AC	6
AC Volt Amps Inrush	30
AC Volt Amps Holding	16
Watts DC	10.6

Solenoid Manual operator included.

UL Listed: 3" - 12"

\*Optional material available for Seawater Service

## When Ordering, Please Specify

1. Catalog No. 134-05
2. Valve Size
3. Pattern - Globe or Angle
4. Pressure Class
5. Threaded, Flanged or Grooved
6. Material Desired
7. Energized or De-energized to Open Main Valve
8. Solenoid Enclosure, Voltage & Hertz
9. When Vertically Installed



134-05 (R-05/2017)

## CLA-VAL

1701 Placentia Avenue • Costa Mesa CA 92627

800-942-6326 • Fax: 949-548-5441 • Web Site: [cla-val.com](http://cla-val.com) • E-mail: [info@cla-val.com](mailto:info@cla-val.com)

### CLA-VAL CANADA

4687 Christie Drive  
Beamsville, Ontario  
Canada L0R 1B4  
Phone: 905-563-4963  
Fax: 905-563-4040  
E-mail: [sales@cla-val.ca](mailto:sales@cla-val.ca)

### CLA-VAL EUROPE

Chemin des Mésanges 1  
CH-1032 Romanel/  
Lausanne, Switzerland  
Phone: 41-21-643-15-55  
Fax: 41-21-643-15-50  
E-mail: [cla-val@cla-val.ch](mailto:cla-val@cla-val.ch)

### CLA-VAL UK

Dainton House, Goods Station Road  
Turbridge Wells  
Kent TN1 2 DH England  
Phone: 44-1892-514-400  
Fax: 44-1892-543-423  
E-mail: [info@cla-val.co.uk](mailto:info@cla-val.co.uk)

### CLA-VAL FRANCE

Porte du Grand Lyon 1  
ZAC du Champ du Périer  
France - 01700 Neyron  
Phone: 33-4-72-25-92-93  
Fax: 33-4-72-25-04-17  
E-mail: [cla-val@cla-val.fr](mailto:cla-val@cla-val.fr)

### CLA-VAL PACIFIC

45 Kennaway Road  
Woolston, Christchurch, 8023  
New Zealand  
Phone: 64-39644860  
[www.cla-valpacific.com](http://www.cla-valpacific.com)  
E-mail: [info@cla-valpacific.com](mailto:info@cla-valpacific.com)



— MODEL — **134-60**

# Seawater Service Solenoid Operated Deluge Valve



134G-60

- Fast Acting Solenoid Control
- Reliable Drip Tight Shut-off
- Simple Design, Proven Reliable
- Easy Installation & Maintenance

The Cla-Val Model 134-60 Seawater Service Solenoid Control Valve is an on-off control valve which either opens or closes upon receiving an electrical signal to the solenoid pilot control. This valve consists of UL Listed 100GS/2100GS Hytrol Main Valve, a three-way solenoid valve and an auxiliary pilot valve. This pilot control system alternately applies pressure to/or relieves pressure from the diaphragm chamber of the main valve. It is furnished either normally open (de-energize solenoid to open) or normally closed (energized solenoid to open).

### Schematic Diagram

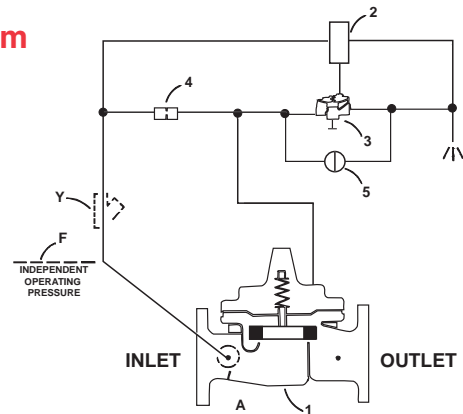

### Item Description

- |   |  |
|---|--|
| 1 | 100GS/2100GS UL Listed Hytrol Main Valve |
| 2 | CS3S Solenoid Control                    |
| 3 | 100-01 Auxiliary Hytrol                  |
| 4 | X58C Restriction Assembly                |
| 5 | CK2 Two-Way Manual Release Valve         |

### Specification

**SIZES** Globe: 3" - 10" flanged  
Angle: 3" - 10" flanged

**END DETAILS** Ductile Iron 150 ANSI B16.42 flanged  
Cast Steel 150 ANSI B16.5 flanged

**PRESSURE RATINGS** 150 class, 250 psi maximum (Ductile Iron)  
150 class, 285 psi maximum (Cast Steel)  
300 class, 400 psi maximum

**TEMPERATURE RANGE** Water: to 180° F. Max

### Functional Data

Valve Size		Inches	3	4	6	8	10
		mm	80	100	150	200	250
Cv Factor	<b>Globe Pattern</b>	Gal./Min. (gpm.)	115	200	440	770	1245
		Litres/Sec. (L/s)	27.6	48	105.6	184.8	299
	<b>Angle Pattern</b>	Gal./Min. (gpm.)	139	240	541	990	1575
		Litres/Sec. (L/s)	33.4	58	130	238	378

### Materials

#### Main valve body & cover

Ductile Iron ASTM A-536\*  
Cast Steel ASTM A216-WCB\*  
Naval Bronze ASTM B61  
Nickel Aluminum Bronze ASTM B148 C95800  
Super Duplex Stainless Steel ASTM A890 GR5A  
Stainless Steel ASTM A743-CF-8M

#### Main valve trim:

Bronze / Monel

#### Tubing & Fittings

316 SST, Monel, or 2507 SDS

#### Pilot control system:

Cast Bronze ASTM B61  
UL Listed 3" - 10"

### Cover Capacity

Valve Size	Displacement
3"	.080 gal
4"	.169 gal
6"	.531 gal
8"	1.26 gal
10"	2.51 gal

100GS (Globe)

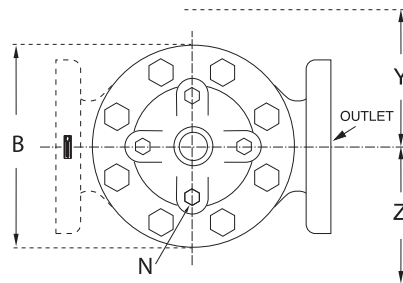
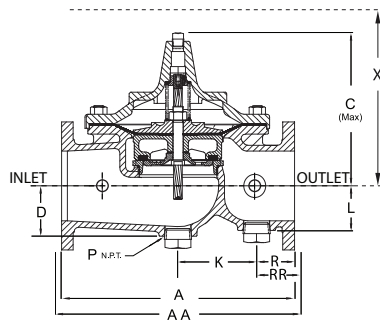

2100GS (Angle)

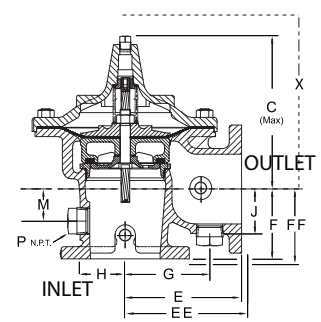

Valve Size (in)	3	4	6	8	10
A 150 ANSI	12.00	15.00	20.00	25.38	29.75
AA 300 ANSI	13.25	15.62	21.00	26.38	31.12
B Dia.	9.12	11.50	15.75	20.00	23.62
C Max.	8.19	10.62	13.28	16.00	17.12
D	2.56	3.19	4.31	5.16	8.50
E 150 ANSI	7.00	8.50	10.00	12.69	14.88
EE 300 ANSI	--	8.81	10.50	13.19	--
F 150 ANSI	4.00	4.97	6.00	8.00	8.62
FF 300 ANSI	--	5.28	6.50	8.50	--
G	4.75	5.94	7.25	8.50	10.50
H	2.69	2.81	3.88	5.31	6.56
J	2.56	2.81	3.81	4.81	5.81
K	7.00	4.03	6.75	17.00	15.50
L	2.56	2.81	3.81	4.81	8.50
M	1.75	2.41	2.75	4.00	4.24
N NPT	1/2"-14	3/4"-14	3/4"-14	1"-11 1/2"	1"-11 1/2"
P NPT	1-1/4"-11	2"-11 1/1/2"			
R 150 ANSI	2.50	3.47	3.25	4.19	7.12
RR 150 ANSI	3.12	3.78	3.75	4.69	7.81
X Pilot System	15.00	17.00	29.00	31.00	33.00
Y Pilot System	11.00	12.00	20.00	22.00	24.00
Z Pilot System	11.00	12.00	20.00	22.00	24.00

Valve Size (mm)	80	100	150	200	250
A 150 ANSI	305	381	508	645	756
AA 300 ANSI	337	397	533	670	791
B Dia.	232	292	400	508	600
C Max.	208	270	340	406	435
D	65	81	110	131	216
E 150 ANSI	178	216	254	322	378
EE 300 ANSI	--	224	267	350	--
F 150 ANSI	102	126	152	203	219
FF 300 ANSI	--	134	165	216	--
G	121	151	184	216	267
H	68	71	99	135	167
J	65	71	97	122	148
K	178	102	171	432	394
L	65	71	97	122	216
M	45	61	70	102	108
N NPT	1/2"-14	3/4"-14	3/4"-14	1"-11 1/2"	1"-11 1/2"
P NPT	1-1/4"-11	2"-11 1/1/2"			
R 150 ANSI	64	88	83	106	181
RR 150 ANSI	79	96	95	119	198
X Pilot System	381	432	737	787	838
Y Pilot System	279	305	508	559	610
Z Pilot System	279	305	508	559	610

**Pilot System Specifications**

**Temperature Range**

Water: to 180°F

**Fluids**

Air, water, light oils

**Rubber Parts**

Buna-N® Synthetic Rubber

**Solenoid Control\***

Body:

316 SS

Enclosure:

NEMA Type 1, 2, 3, 3S, 4, 4X general purpose watertight

NEMA Type 6, 6P, 7, 9 watertight

Explosion Proof available at extra cost

**Voltages:**

110, 220 -50Hz AC

24, 120, 240, 480 -60Hz AC

6, 12, 24, 120, 240 - DC

Others available at extra cost

Max. operating pressure differential: 200 psi

**Coil:**

Insulation molded Class F

Watts AC 6

AC Volt Amps Inrush 30

AC Volt Amps Holding 16

Watts DC 10.6

Manual operator available at extra cost.

UL Listed: 3" - 10"

\*Optional material available for Seawater Service

**When Ordering, Please Specify**

1. Catalog No. 134-60
2. Valve Size
3. Pattern - Globe or Angle
4. Pressure Class
5. Threaded, Flanged or Grooved
6. Material Desired
7. Energized or De-energized to Open Main Valve
8. Solenoid Enclosure, Voltage & Hertz
9. When Vertically Installed



**CLA-VAL**

1701 Placentia Avenue • Costa Mesa CA 92627

800-942-6326 • Fax: 949-548-5441 • Web Site: cla-val.com • E-mail: info@cla-val.com

**CLA-VAL CANADA**

4687 Christie Drive  
Beamsville, Ontario  
Canada L0R 1B4  
Phone: 905-563-4963  
Fax: 905-563-4040  
E-mail sales@cla-val.ca

**CLA-VAL EUROPE**

Chemin des Mésanges 1  
CH-1032 Romanel/  
Lausanne, Switzerland  
Phone: 41-21-643-15-55  
Fax: 41-21-643-15-50  
E-mail: cla-val@cla-val.ch

**CLA-VAL UK**

Dainton House, Goods Station Road  
Tunbridge Wells  
Kent TN1 2 DH England  
Phone: 44-1892-514-400  
Fax: 44-1892-543-423  
E-mail: info@cla-val.co.uk

**CLA-VAL FRANCE**

Porte du Grand Lyon 1  
ZAC du Champ du Périer  
France - 01700 Neyron  
Phone: 33-4-72-25-92-93  
Fax: 33-4-72-25-04-17  
E-mail: cla-val@cla-val.fr

**CLA-VAL PACIFIC**

45 Kennaway Road  
Woolston, Christchurch, 8023  
New Zealand  
Phone: 64-39644860  
www.cla-valpacific.com  
E-mail: info@cla-valpacific.com

# Optional Solenoid Control Arrangements

134-60

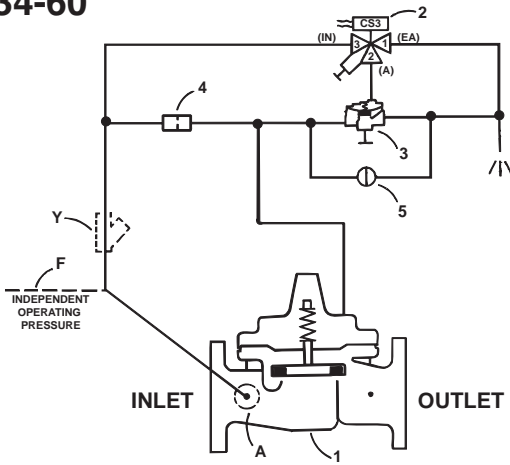

134-30

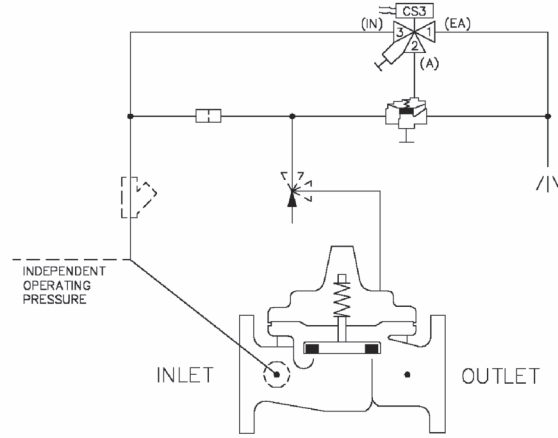

134-47

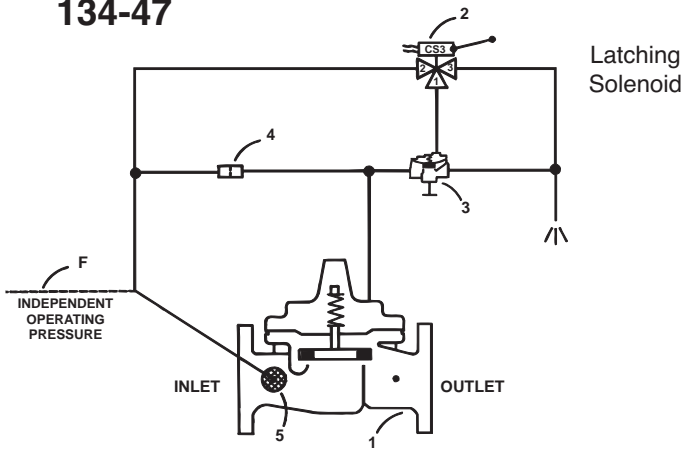

134-61

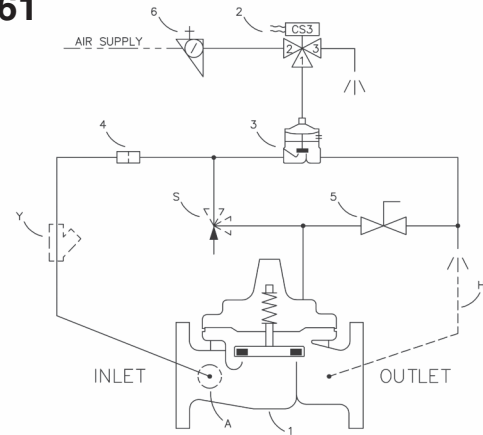

134-50

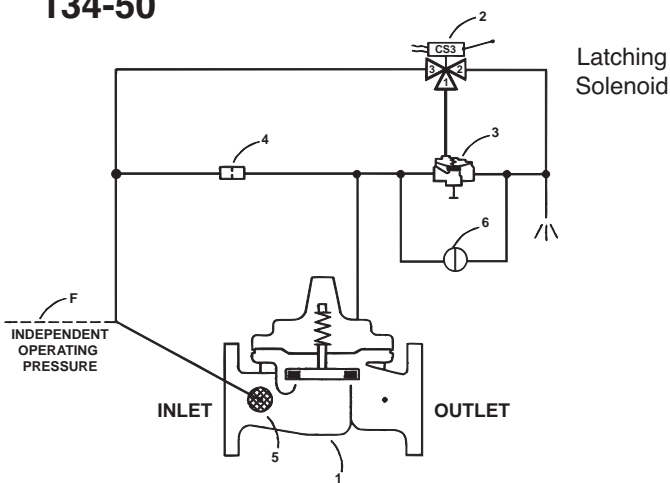

134-81

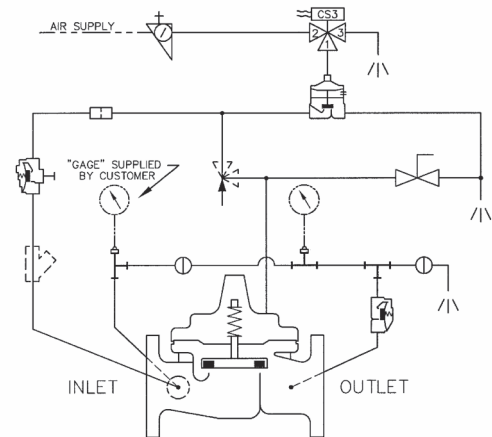

# Optional Solenoid Control Arrangements

134-56

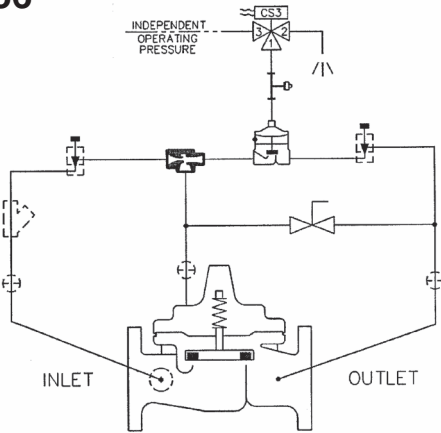

134-82

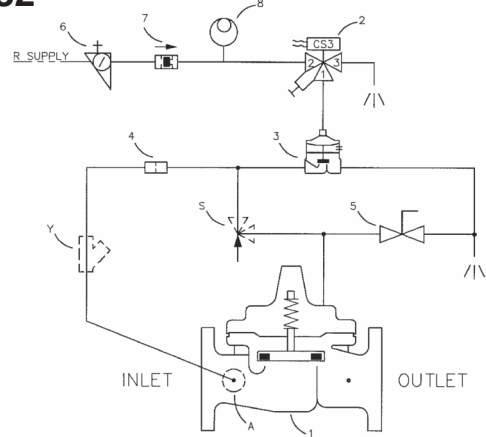

134-57

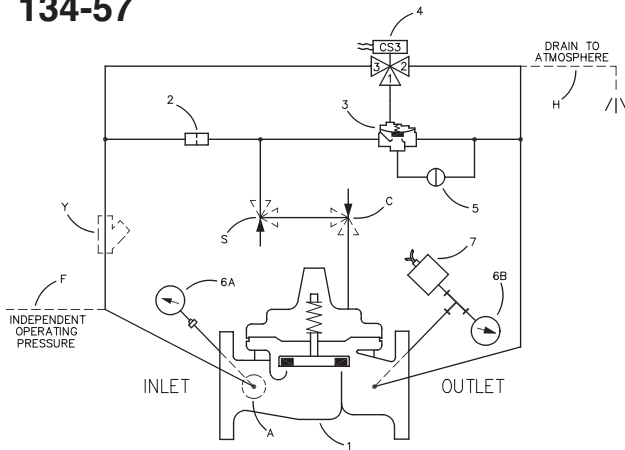

134-83

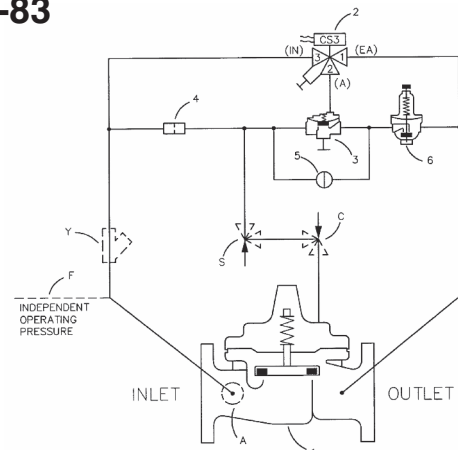

134-05



134G-60



— MODEL — **834-05**  
**800 Series (Tubular Diaphragm Valve)**  
**Fire Deluge Valve**



- Low Head Loss
- Cast Steel Construction
- Stainless Steel Pilot and Tubing
- Stainless Steel Solenoid
- Anti-Cavitation Design
- Fusion Coated Epoxy Inside and Out
- Nickel Aluminum Bronze Construction Option (Alloy C95800)
- Duplex Stainless Steel Construction Option (Alloy 2205)
- Low Maintenance
- Simple and Reliable Operation
- 1-Year Warranty

The Cla-Val 834-05 Deluge Valve is a pressure-operated, in-line axial valve. A tube diaphragm actuates the valve, which is comprised of three major components: 1) Tube 2) Barrier and 3) Body. There is only one moving part in the valve - the tube diaphragm. There are no shafts, packing, stem guides or springs.

The tube diaphragm is a one piece, homogeneous nitrile rubber part which is extremely durable. The ends of the tube are thick solid rubber, designed to fit between mating flanges. This design eliminates the possibility of cutting the tube diaphragm due to over tightening or piping misalignment during installation.

The tube forms a drip tight seal around the barrier when the pressure is equalized between the valve inlet and the control chamber. When pressure is removed from the control chamber, the valve is open. The minimum recommended operating pressure is 40 P.S.I. of inlet pressure.

**Principle of Operation**

- Control Options**
- Electric Operation
  - Pneumatic Operation
  - Hydraulic Operation
  - Manual Operation

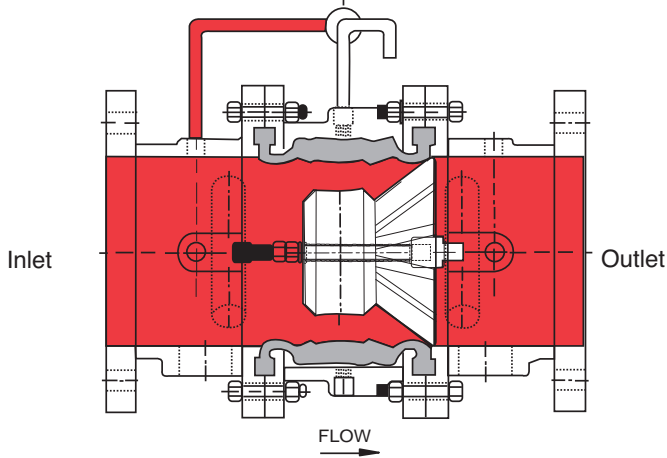

**Full Open Operation**

When pressure in control chamber is relieved, the valve is open.

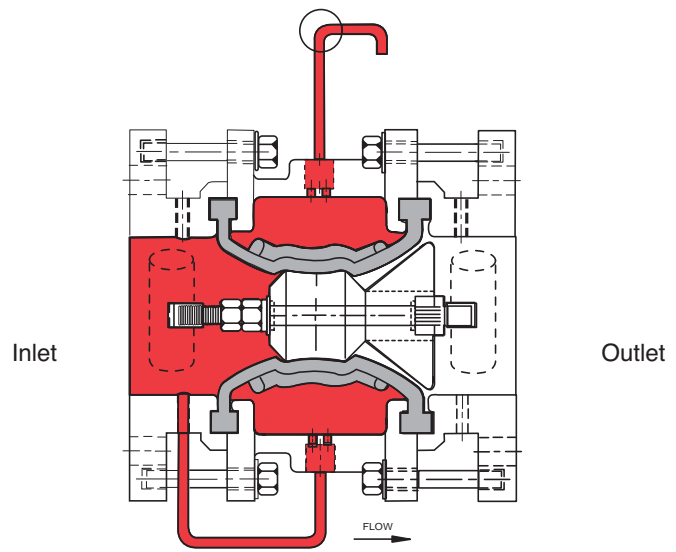

**Tight Closing Operation**

Water pressure from valve inlet is applied to the control chamber. Valve closes bubble tight.

Dimensions

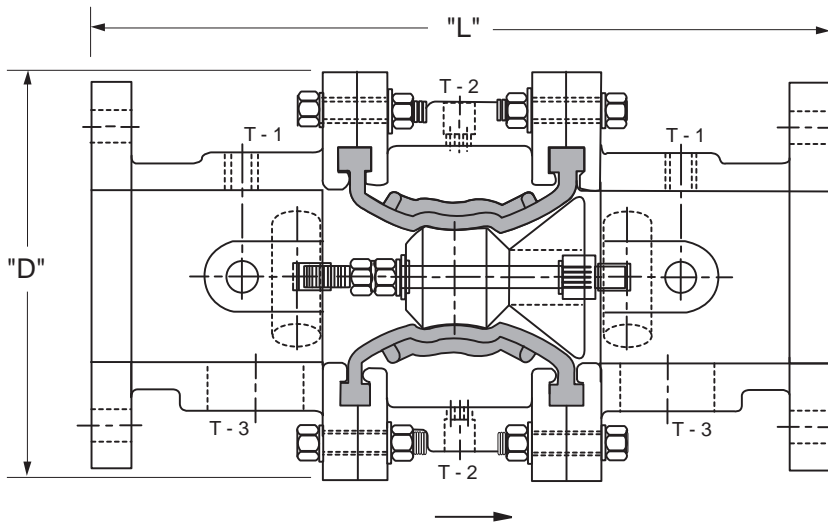

Valve Size (Inches)	4	6	8	10
L	17.25	18.25	20.00	22.00
D	9.5	11.75	14.00	16.00
T-1/T-2 (NPT)	1/2	1/2	1/2	1/2
T-3 (NPT)	2	2	2	2
Approx. Wt. (Lbs.)	151	196	285	330

Valve Size (mm)	100	150	200	250
L	438	464	508	559
D	241	299	356	406
T-1/T-2 (NPT)	1/2	1/2	1/2	1/2
T-3 (NPT)	2	2	2	2
Approx. Wt. (kgs)	68	89	129	150

4", 6", 8"  
Factory Mutual  
Approved  
(with approved  
Pilot  
Components)

FLOW FACTORS		
SIZE (IN)	CV (gpm)	KV
4"	340	77.3
6"	885	201
8"	1667	379
*10"	2424	550

\*Calculated

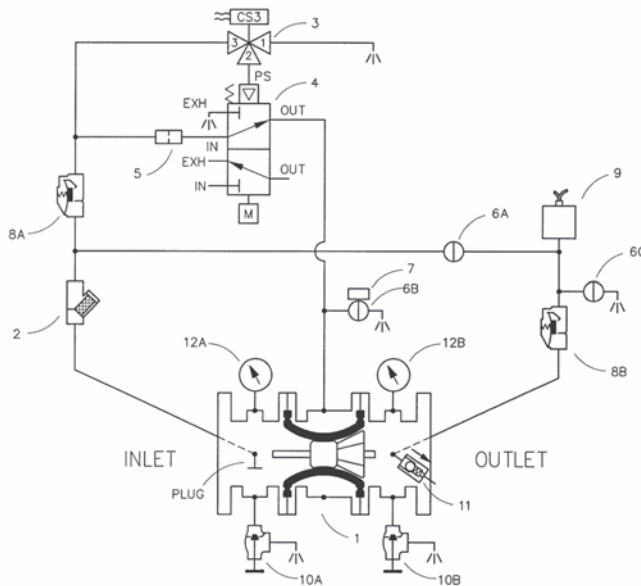

MAIN VALVE

Ends: Flanged ANSI B16.5 (150lb Class)  
 Body: Cast Steel (ASTM A216 WCB)  
 Tube Diaphragm: Nitrile Rubber  
 Barrier: Urethane  
 Bolts: 316 SS  
 Pressure: 250 psig (17.24 BAR)  
 Temp. Range: 32° F to 180° F (0° C to 82.2° C)

MAIN VALVE OPTIONS

Body: Nickel Aluminum Bronze (Alloy C95800) or Duplex SS (Alloy 2205)

PILOT VALVE

All Parts: Bronze / Monel  
 O-Rings: Nitrile Rubber  
 Control Range: 20 to 250 PSIG  
 Pilot Pressure Range: 20 to 250 PSIG  
 Operation: Latches in operated position; manual reset

PILOT VALVE OPTIONS

All Parts: Monel (Alloy 400)  
 Operation: Non-latching

Item Description

- 1 800GS TDV Main Valve
- 2 X43 "Y" Strainer
- 3 CS3 Solenoid Control
- 4 Latching Deluge Pilot
- 5 X58C Restriction Assembly
- 6 CK2 Cock (Isolation Valve)

Item Description

- 9 Pressure Switch
- 10 CGA Angle Valve
- 11 Automatic Drain Valve
- 12 Pressure Gauge

Cla-Val 800 Series Control Valves operate with maximum efficiency when mounted in horizontal or vertical piping. We recommend isolation valves be installed on inlet and outlet for maintenance. Adequate space above and around the valve for service personnel should be considered essential. A regular maintenance program should be established based on the specific application data. However, we recommend a thorough inspection be done at least once a year. Consult factory for specific recommendations.



E-834-05 (R-3/2011)

CLA-VAL

1701 Placentia Avenue • Costa Mesa CA 92627

800-942-6326 • Fax: 949-548-5441 • Web Site: cla-val.com • E-mail: info@cla-val.com

CLA-VAL CANADA

4687 Christie Drive  
 Beamsville, Ontario  
 Canada L0R 1B4  
 Phone: 905-563-4963  
 Fax: 905-563-4040  
 E-mail sales@cla-val.ca

CLA-VAL EUROPE

Chemin des Mésanges 1  
 CH-1032 Romanel/  
 Lausanne, Switzerland  
 Phone: 41-21-643-15-55  
 Fax: 41-21-643-15-50  
 E-mail: cla-val@cla-val.ch

CLA-VAL UK

Dainton House, Goods Station Road  
 Tunbridge Wells  
 Kent TN11 2 DH England  
 Phone: 44-1892-514-400  
 Fax: 44-1892-543-423  
 E-mail: info@cla-val.co.uk

CLA-VAL FRANCE

Porte du Grand Lyon 1  
 ZAC du Champ du Périer  
 France - 01700 Neyron  
 Phone: 33-4-72-25-92-93  
 Fax: 33-4-72-25-04-17  
 E-mail: cla-val@cla-val.fr

CLA-VAL PACIFIC

45 Kennaway Road  
 Woolston, Christchurch, 8023  
 New Zealand  
 Phone: 64-39644860  
 www.cla-valpacific.com  
 E-mail: info@cla-valpacific.com



— MODEL — **834-60**

**800 Series (Tubular Diaphragm Valve)**

**Seawater Fire Deluge Valve**



- Low Head Loss
- Cast Steel Construction
- Stainless Steel Pilot and Tubing
- Stainless Steel Solenoid
- Anti-Cavitation Design
- Fusion Coated Epoxy Inside and Out
- Nickel Aluminum Bronze Construction Option (Alloy C95800)
- Duplex Stainless Steel Construction Option (Alloy 2205)
- Low Maintenance
- Simple and Reliable Operation
- 1-Year Warranty

The Cla-Val Model 834-60 Seawater Deluge Valve is a pressure operated, in-line axial valve. A tube diaphragm actuates the valve, which is comprised of three major components: 1) Tube 2) Barrier and 3) Body. There is only one moving part in the valve - the tube diaphragm. There are no shafts, packing, stem guides or springs. The tube diaphragm is a one piece, homogeneous nitrile rubber part which is extremely durable. The ends of the tube are thick solid rubber, designed to fit between mating flanges. This design eliminates the possibility of cutting the tube diaphragm due to over tightening or piping misalignment during installation.

The tube forms a drip tight seal around the barrier when the pressure is equalized between the valve inlet and the control chamber. When pressure is removed from the control chamber, the valve is open. The minimum recommended operating pressure is 40 P.S.I. of inlet pressure.

**Principle of Operation**

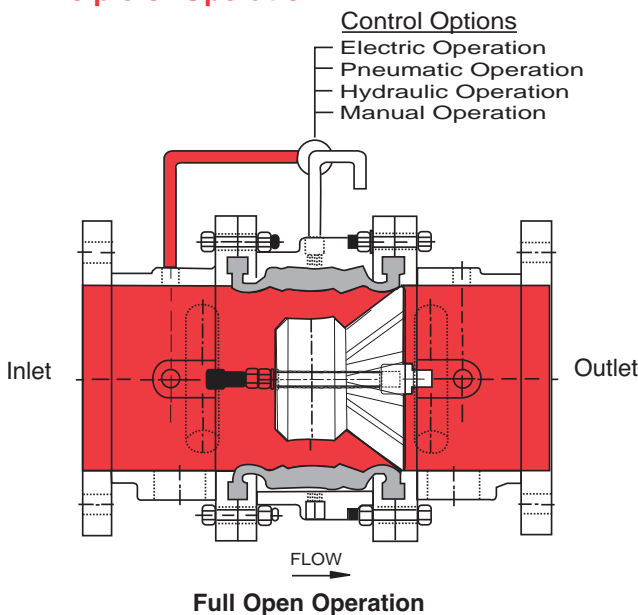

When pressure in control chamber is relieved, the valve is open.

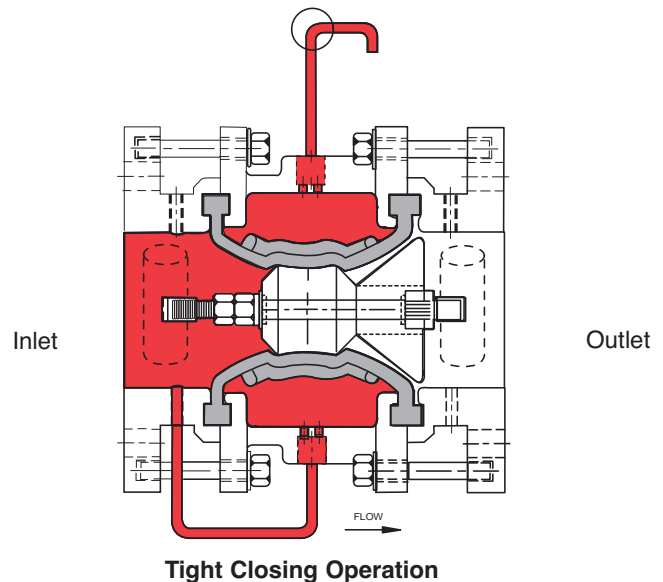

Water pressure from valve inlet is applied to the control chamber. Valve closes bubble tight.

Dimensions

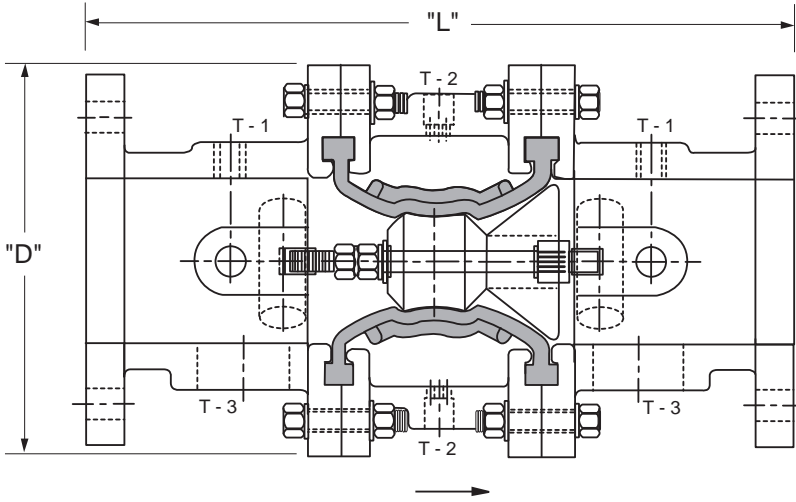

Valve Size (Inches)	4	6	8	10
L	17.25	18.25	20.00	22.00
D	9.5	11.75	14.00	16.00
T-1/T-2 (NPT)	1/2	1/2	1/2	1/2
T-3 (NPT)	2	2	2	2
Approx. Wt. (Lbs.)	151	196	285	330

Valve Size (mm)	100	150	200	250
L	438	464	508	559
D	241	299	356	406
T-1/T-2 (NPT)	1/2	1/2	1/2	1/2
T-3 (NPT)	2	2	2	2
Approx. Wt. (kgs)	68	89	129	150

4", 6", 8" Factory Mutual Approved (with approved Pilot Components)

FLOW FACTORS		
SIZE (IN)	CV (gpm)	KV
4"	340	77.3
6"	885	201
8"	1667	379
*10"	2424	550

\*Calculated

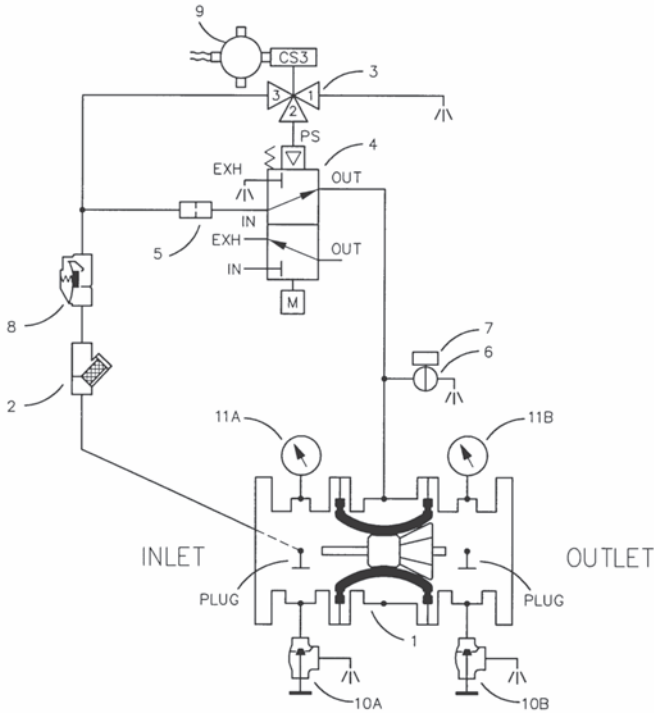

MAIN VALVE

- Ends: Flanged ANSI B16.5 (150lb Class)
- Body: Cast Steel (ASTM A216 WCB)
- Tube Diaphragm: Nitrile Rubber
- Barrier: Urethane
- Bolts: 316 SS
- Pressure: 250 psig (17.24 BAR)
- Temp. Range: 32° F to 180° F (0° C to 82.2° C)

MAIN VALVE OPTIONS

- Body: Nickel Aluminum Bronze (Alloy C95800) or Duplex SS (Alloy 2205)

PILOT VALVE

- All Parts: Bronze / Monel
- O-Rings: Nitrile Rubber
- Control Range: 20 to 250 PSIG
- Pilot Pressure Range: 20 to 250 PSIG
- Operation: Latches in operated position; manual reset

PILOT VALVE OPTIONS

- All Parts: Monel (Alloy 400)
- Operation: Non-latching

Cla-Val 800 Series Control Valves operate with maximum efficiency when mounted in horizontal or vertical piping. We recommend isolation valves be installed on inlet and outlet for maintenance. Adequate space above and around the valve for service personnel should be considered essential. A regular maintenance program should be established based on the specific application data. However, we recommend a thorough inspection be done at least once a year. Consult factory for specific recommendations.



E-834-60 (R-3/2011)

CLA-VAL

1701 Placentia Avenue • Costa Mesa CA 92627  
 800-942-6326 • Fax: 949-548-5441 • Web Site: cla-val.com • E-mail: info@cla-val.com

<p><b>CLA-VAL CANADA</b>                  4687 Christie Drive                  Beamsville, Ontario                  Canada L0R 1B4                  Phone: 905-563-4963                  Fax: 905-563-4040                  E-mail sales@cla-val.ca</p>	<p><b>CLA-VAL EUROPE</b>                  Chemin des Mésanges 1                  CH-1032 Romanel/                  Lausanne, Switzerland                  Phone: 41-21-643-15-55                  Fax: 41-21-643-15-50                  E-mail: cla-val@cla-val.ch</p>	<p><b>CLA-VAL UK</b>                  Dainton House, Goods Station Road                  Tunbridge Wells                  Kent TN11 2 DH England                  Phone: 44-1892-514-400                  Fax: 44-1892-543-423                  E-mail: info@cla-val.co.uk</p>	<p><b>CLA-VAL FRANCE</b>                  Porte du Grand Lyon 1                  ZAC du Champ du Pénier                  France - 01700 Neyron                  Phone: 33-4-72-25-92-93                  Fax: 33-4-72-25-04-17                  E-mail: cla-val@cla-val.fr</p>	<p><b>CLA-VAL PACIFIC</b>                  45 Kennaway Road                  Woolston, Christchurch, 8023                  New Zealand                  Phone: 64-39644860                  www.cla-valpacific.com                  E-mail: info@cla-valpacific.com</p>
---	--	--	--	---

©COPYRIGHT CLA-VAL 2018 Printed in USA. Specifications subject to change without notice.

# Optional Tubular Diaphragm Valve Control Arrangements

803-35

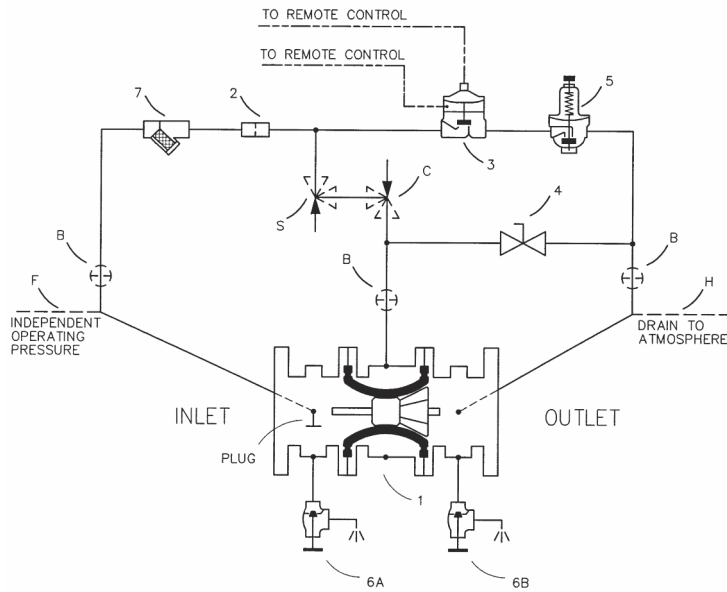

834-60

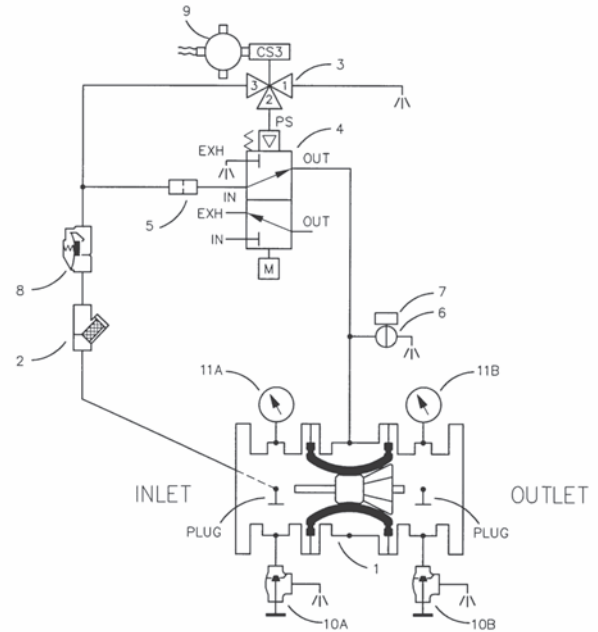

814-01

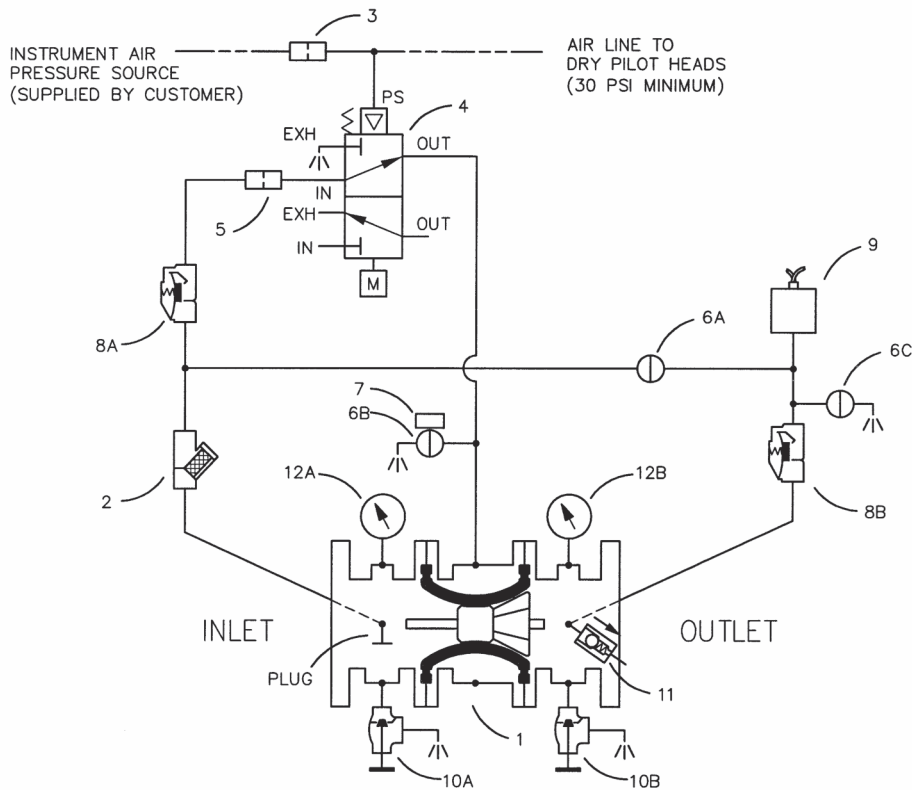

# Optional Tubular Diaphragm Valve Control Arrangements

834-61

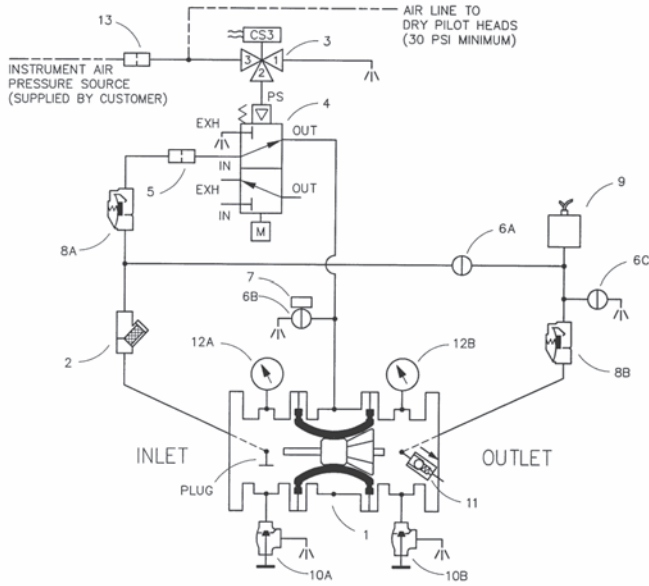

834-62

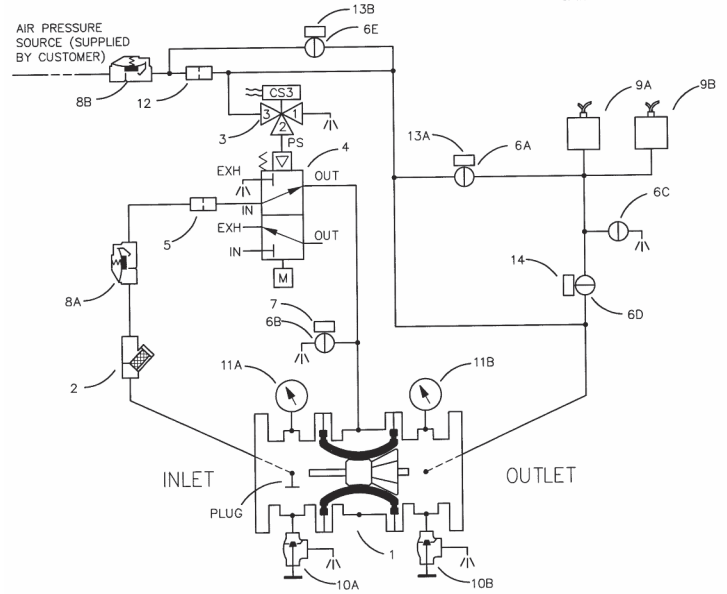

834-05

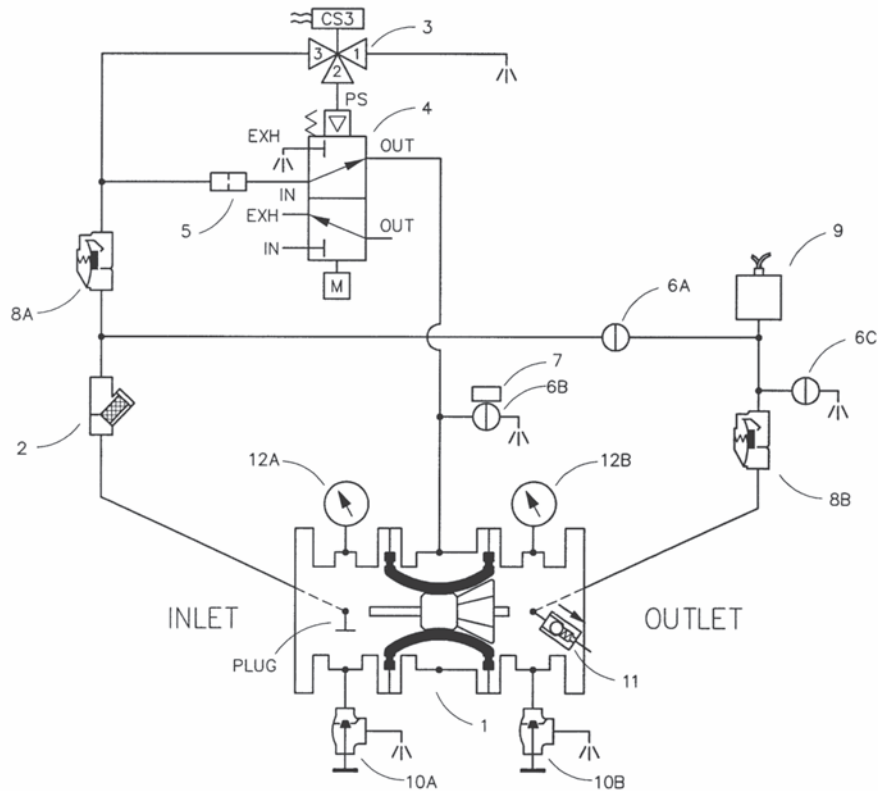

# Series 403

## Pneumatically Operated Remote Control Valve for Freshwater & Seawater Service



403G-11A

- Single Seat with Resilient Disc Insures Tight Seal
- Simply Designed with Few Working Parts
- Quick Response to Remote Control
- Fully Supported Frictionless Diaphragm
- Leak-proof Service Assured – No Packing Glands
- Single Tube Line Required for Control
- Opens Wide for Minimum Flow Resistance

The Cla-Val 403 Series Remote Control Valve is used where “on-off” control is required. Pressure signals from a remote control “open or close” a small auxiliary valve installed on the main valve cover, which in turn opens or closes the main valve. Only the small amount of fluid in the auxiliary valve cover must pass through the remote control pilot in order to fully open or close the larger main valve.

The Model 403 Series consists of a 100-01 Hytrol main valve and a small Hytrol auxiliary valve. Both the main valve and the auxiliary valve are single-seated, diaphragm operated globe type valves. Line pressure applied to the auxiliary valve cover closes the main valve drip tight.

**For Seawater Service use 100S/2100S or 100GS/2100GS Main Valve**

### Specifications

<b>Sizes</b>	Globe: 1 1/2" - 24" flanged Angle: 1 1/2" - 16" flanged
<b>End Details</b>	125 and 250 ANSI B16.1
<b>Pressure Ratings</b>	150 class - 250 psi Max. 300 class - 400 psi Max.
<b>Temperature Range</b>	Water: to 180° F. Max.
<b>Materials</b>	<b>Main valve body &amp; cover:</b> Ductile Iron ASTM A-536* Cast Steel ASTM A216-WCB* Naval Bronze ASTM B-61 Nickel Aluminum Bronze ASTM B148 Super Duplex Stainless Steel Stainless Steel ASTM A743-CF-8M

**Main valve trim:**  
Bronze ASTM B61  
Monel  
Stainless Steel 316

**Pilot control system:**  
Cast bronze ASTM B61 with monel trim  
Stainless Steel 316 Tubing & Fitting

\*Internally & Externally Epoxy Coated

### Schematic Diagram

Item	Description
1	100-01 Hytrol (Main Valve)
2	X47A Ejector
3	100-02 Powertrol
4	CK2 Ball Valve

### Optional Features

Item	Description
A	X46A Flow Clean Strainer
F	Independent Operating Pressure
H	Drain to Atmosphere

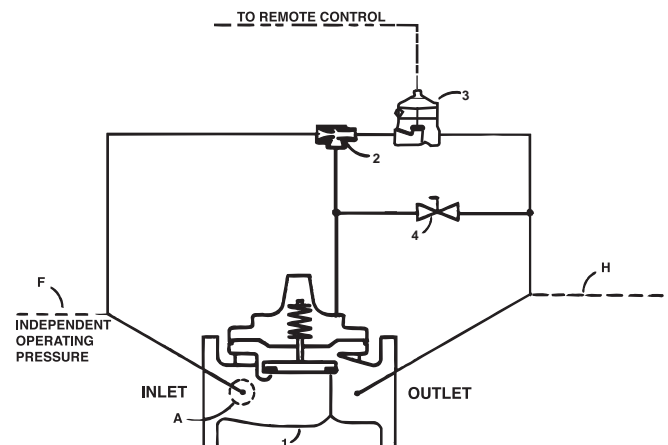

Valve Size (Inches)	1½	2	2½	3	4	6	8	10	12	14	16	24	36
A Threaded	7.25	9.38	11.00	12.50	—	—	—	—	—	—	—	—	—
AA 150 ANSI	8.50*	9.38	11.00	12.00	15.00	20.00	25.38	29.75	34.00	39.00	41.38	61.50	76.00
AAA 300 ANSI	9.00*	10.00	11.62	13.25	15.62	21.00	26.38	31.12	35.50	40.50	43.50	63.24	78.00
B Dia.	5.62	6.62	8.00	9.12	11.50	15.75	20.00	23.62	28.00	32.75	35.50	53.16	66.00
C Max.	5.50	6.50	7.56	8.19	10.62	13.38	16.00	17.12	20.88	24.19	25.00	43.93	61.50
CC Max.	—	5.00	—	6.50	8.80	11.10	—	—	—	—	—	—	—
D Threaded	3.25	4.75	5.50	6.25	—	—	—	—	—	—	—	—	—
DD 150 ANSI	4.00*	4.75	5.50	6.00	7.50	10.00	12.75	14.88	17.00	19.50	20.81	—	—
DDD 300 ANSI	4.25*	5.00	5.88	6.38	7.88	10.50	13.25	15.56	17.75	20.25	21.62	—	—
E	1.12	1.50	1.69	2.56	3.19	4.31	5.31	9.25	10.75	12.62	15.50	17.75	24.56
F 150 ANSI	2.50	3.00	3.50	3.75	4.50	5.50	6.75	8.00	9.50	10.50	11.75	19.25	28.00
FF 300 ANSI	3.06	3.25	3.75	4.13	5.00	6.25	7.50	8.75	10.25	11.50	12.75	—	—
G Threaded	1.88	3.25	4.00	4.50	—	—	—	—	—	—	—	—	—
GG 150 ANSI	4.00*	3.25	4.00	4.00	5.00	6.00	8.00	8.62	13.75	14.88	15.69	—	—
GGG 300 ANSI	4.25*	3.50	4.31	4.38	5.31	6.50	8.50	9.31	14.50	15.62	16.50	—	—
H NPT Body Tapping	¾	¾	½	½	¾	¾	1	1	1	1	1	1	2
J NPT Cover Center Plug	¼	½	½	½	¾	¾	1	1	1¼	1½	2	1½	2
K NPT Cover Tapping	¾	¾	½	½	¾	¾	1	1	1	1	1	1	2
Valve Stem Internal Thread UNF	10-32	10-32	10-32	¼-28	¼-28	¾-24	¾-24	¾-24	¾-24	¾-24	¾-24	½-20	¾-16
Stem Travel	0.4	0.6	0.7	0.8	1.1	1.7	2.3	2.8	3.4	4.0	4.5	6.75	10.12
Approx. Ship Wt. Lbs.	15	35	50	70	140	285	500	780	1165	1600	2265	6200	11470

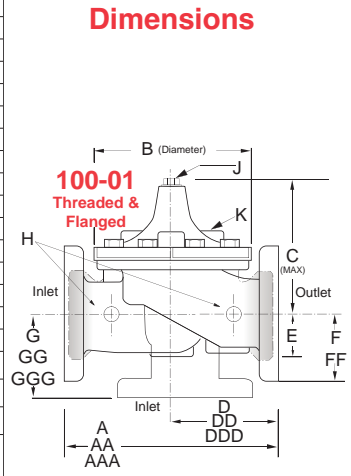

Valve Size (mm)	40	50	65	80	100	150	200	250	300	350	400	600	900
A Threaded	184	238	279	318	—	—	—	—	—	—	—	—	—
AA 150 ANSI	216*	238	279	305	381	508	645	756	864	991	1051	1562	1930
AAA 300 ANSI	229*	254	295	337	397	533	670	790	902	1029	1105	1606	1981
B Dia.	143	168	203	232	292	400	508	600	711	832	902	1350	1676
C Max.	140	165	192	208	270	340	406	435	530	614	635	1116	1562
CC Max.	104	127	—	165	223	281	—	—	—	—	—	—	—
D Threaded	83	121	140	159	—	—	—	—	—	—	—	—	—
DD 150 ANSI	102*	121	140	152	191	254	324	378	432	495	528	—	—
DDD 300 ANSI	108*	127	149	162	200	267	337	395	451	514	549	—	—
E	29	38	43	65	81	110	135	235	273	321	394	451	624
F 150 ANSI	64	76	89	95	114	140	171	203	241	267	298	489	711
FF 300 ANSI	78	83	95	105	127	159	191	222	260	292	324	—	—
G Threaded	48	83	102	114	—	—	—	—	—	—	—	—	—
GG 150 ANSI	102*	83	102	102	127	152	203	219	349	378	399	—	—
GGG 300 ANSI	102*	89	110	111	135	165	216	236	368	397	419	—	—
H NPT Body Tapping	¾	¾	½	¾	¾	1	1	1	1	1	1	2	2
J NPT Cover Center Plug	½	½	½	¾	¾	1	1	1¼	1½	2	1½	2	2
K NPT Cover Tapping	¾	¾	½	¾	¾	1	1	1	1	1	1	2	2
Valve Stem Internal Thread UNF	10-32	10-32	10-32	¼-28	¼-28	¾-24	¾-24	¾-24	¾-24	¾-24	¾-24	½-20	¾-16
Stem Travel	10	15	18	20	28	43	58	71	86	102	114	171	257
Approx. Ship Wt. Kgs.	7	16	23	32	64	129	227	354	528	726	1027	2812	5200

### When Ordering, Please Specify

1. Catalog No. 403 Series
2. Valve Size
3. Pattern - Globe or Angle
4. Pressure Class
5. Threaded, Flanged or Grooved
6. Trim Material
7. Adjustment Range
8. Desired Options
9. When Vertically Installed

### Valve Capacity

Valve Sizes (inches)	1 1/2"	2"	2 1/2"	3"	4"	6"	8"	10"	12"	14"	16"	24"	36"
Max. Continuous (gpm)	125	208	300	460	800	1800	3100	4900	7000	8500	11000	28000	—
Max. Intermittent (gpm)	280	460	650	1000	1800	4000	7000	11000	16000	19000	25000	63000	—

### Functional Data

Valve Size	Inches	1½	2	2½	3	4	6	8	10	12	14	16	24	36	
	mm.	40	50	65	80	100	150	200	250	300	350	400	600	900	
C <sub>v</sub> Factor	Globe Pattern	Gal./Min. (gpm.)	32	54	85	115	200	440	770	1245	1725	2300	2940	7655	13320
		Litres/Sec. (l/s.)	7.7	13	20.4	27.6	48	105.6	184.8	299	414	552	706	1837	3200
	Angle Pattern	Gal./Min. (gpm.)	29	61	101	139	240	541	990	1575	2500*	3060*	4200*	—	—
		Litres/Sec. (l/s.)	7	14.6	24.2	33.4	58	130	238	378	600	734.4	1008	—	—

\*Estimated

### Pilot System Specifications

#### Materials

Standard Pilot System Materials  
 Pilot Control: Bronze ASTM B61  
 Trim: Monel  
 Rubber: Buna-N® Synthetic Rubber

#### Optional Pilot System Materials

Pilot Systems are available with optional Stainless Steel or Monel materials at extra cost.  
 Note: Available with remote sensing control.

#### Temperature Range

Water: to 180°F



### CLA-VAL

1701 Placentia Avenue • Costa Mesa CA 92627  
 800-942-6326 • Fax: 949-548-5441 • Web Site: cla-val.com • E-mail: info@cla-val.com

<b>CLA-VAL CANADA</b> 4687 Christie Drive Beamsville, Ontario Canada L0R 1B4 Phone: 905-563-4963 Fax: 905-563-4040 E-mail sales@cla-val.ca	<b>CLA-VAL EUROPE</b> Chemin des Mésanges 1 CH-1032 Romanel/ Lausanne, Switzerland Phone: 41-21-643-15-55 Fax: 41-21-643-15-50 E-mail: cla-val@cla-val.ch	<b>CLA-VAL UK</b> Dainton House, Goods Station Road Tunbridge Wells Kent TN11 2 DH England Phone: 44-1892-514-400 Fax: 44-1892-543-423 E-mail: info@cla-val.co.uk	<b>CLA-VAL FRANCE</b> Porte du Grand Lyon 1 ZAC du Champ du Périer France - 01700 Neyron Phone: 33-4-72-25-92-93 Fax: 33-4-72-25-04-17 E-mail: cla-val@cla-val.fr	<b>CLA-VAL PACIFIC</b> 45 Kennaway Road Woolston, Christchurch, 8023 New Zealand Phone: 64-39644860 www.cla-valpacific.com E-mail: info@cla-valpacific.com
--	---	---	---	--

# 414-01 — MODEL —



## Pneumatically Operated with Manual Reset Deluge Valve for Freshwater & Seawater Service



414-01

- Single Seat with Resilient Disc Insures Tight Seal
- Simply Designed with Few Working Parts
- Quick Response with Manual Reset
- Fully Supported Frictionless Diaphragm
- Leak-proof Service Assured – No Packing Glands
- Single Tube Line Required for Control
- Opens Wide for Minimum Flow Resistance

The Cla-Val 414-01 Remote Control Valve is used where “on-off” control is required. Pressure signals from a remote control “open or close” a small auxiliary valve installed on the main valve cover, which in turn opens or closes the main valve. Once sensing pressure drops to “set” pressure the snap action pilot opens to relieve main valve cover pressure to open deluge valve. Once open the pilot valve must be “manually reset” in order to close the valve.

The Model 414-01 consists of a 100G/2100G Hytrol main valve and a small Hytrol Auxiliary Valve. Both the main valve and the auxiliary valve are single-seated, diaphragm operated globe type valves. Line pressure applied to the auxiliary valve cover closes the main valve drip tight.

### Specifications

**Sizes** Globe: 3” - 10” flanged  
Angle: 3” - 10” flanged

**End Details** 125 and 250 ANSI B16.1

**Pressure Ratings** 125 class - 175 psi Max.  
250 class - 300 psi Max.

**Temperature Range** Water: to 180° F. Max.

**Materials** *Main valve body & cover:*  
Ductile Iron ASTM A-536\*  
Cast Steel ASTM A216-WCB\*  
Naval Bronze ASTM B-61  
Nickel Aluminum Bronze ASTM B148  
Super Duplex Stainless Steel  
Stainless Steel ASTM A743-CF-8M

**Main valve trim:**

Bronze ASTM B61  
Monel

**Pilot control system:**

Cast bronze ASTM B61 with monel trim  
Stainless Steel 316 Tubing & Fitting

**For Seawater Service use 100GS/2100GS Main Valve**

### Schematic Diagram

Item	Description
1	100G/2100G Hytrol (Main Valve)
2	X46A Flow Clean Strainer
3	CDHS-3C-A2-3 Differential Control
4	X58C Restriction Assembly
5	100-01 Auxiliary Hytrol

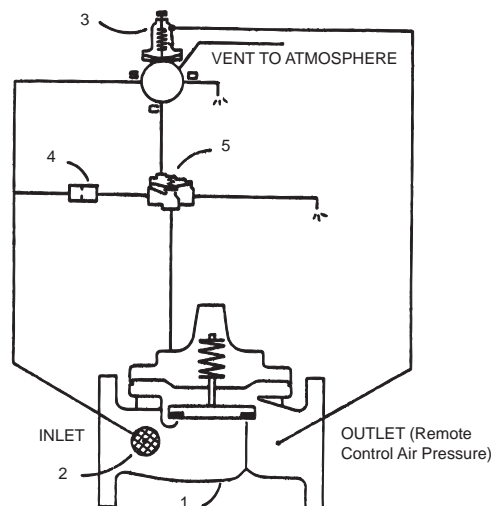

**\*Internally & Externally Epoxy Coated**

## Dimensions

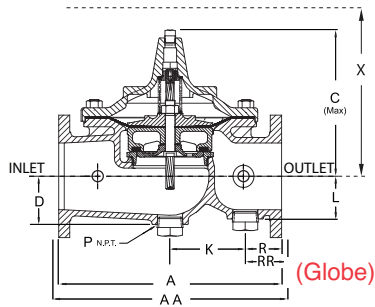

(Globe)

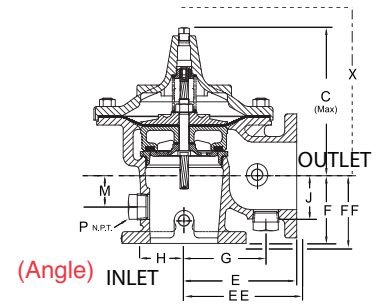
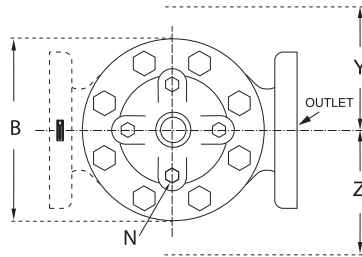

(Angle)

Valve Size (Inches)	3	4	6	8	10
A 150 ANSI	12.00	15.00	20.00	25.38	29.75
AA 300 ANSI	13.25	15.62	21.00	26.38	31.12
B Dia.	9.12	11.50	15.75	20.00	23.62
C Max.	8.19	10.62	13.38	16.00	17.12
D	2.56	3.19	4.31	5.16	8.50
E 150 ANSI	7.00	8.50	10.00	12.69	14.88
EE 300 ANSI	--	8.81	10.50	13.19	--
F 150 ANSI	4.00	4.97	6.00	8.00	8.62
FF 300 ANSI	--	5.28	6.50	8.50	--
G	4.75	5.94	7.25	8.50	10.50
H	2.69	2.81	3.88	5.31	6.56
J	2.56	2.81	3.81	4.81	5.81
K	7.00	4.03	6.75	17.00	15.50
L	2.56	2.81	3.81	4.81	8.50
M	1.75	2.41	2.75	4.00	4.24
N NPT	1/2"-14	3/4"-14	3/4"-14	1"-11 1/2	1"-11 1/2
P NPT	1-1/4"-11 1/2	2"-11 1/2"			
R 150 ANSI	2.50	3.47	3.25	4.19	7.12
RR 300 ANSI	3.12	3.78	3.75	4.69	7.81
X Pilot System	15.00	17.00	29.00	31.00	33.00
Y Pilot System	11.00	12.00	20.00	22.00	24.00
Z Pilot System	11.00	12.00	20.00	22.00	24.00

Valve Size (mm)	80	100	150	200	250
A 150 ANSI	305	381	508	645	756
AA 300 ANSI	337	397	533	670	791
B Dia.	232	292	400	508	600
C Max.	208	270	340	406	435
D	65	81	110	131	216
E 150 ANSI	178	216	254	322	378
EE 300 ANSI	--	224	267	350	--
F 150 ANSI	102	126	152	203	219
FF 300 ANSI	--	134	165	216	--
G	121	151	184	216	267
H	68	71	99	135	167
J	65	71	97	122	148
K	178	102	171	432	394
L	65	71	97	122	216
M	45	61	70	102	108
N NPT	1/2"-14	3/4"-14	3/4"-14	1"-11 1/2	1"-11 1/2
P NPT	1-1/4"-11 1/2	2"-11 1/2"			
R 150 ANSI	64	88	83	106	181
RR 300 ANSI	79	96	95	119	198
X Pilot System	381	432	737	787	838
Y Pilot System	279	305	508	559	610
Z Pilot System	279	305	508	559	610

### Valve Capacity

Valve Sizes (inches)	3"	4"	6"	8"	10"
Max. Continuous (gpm)	460	800	1800	3100	4900
Max. Intermittent (gpm)	1000	1800	4000	7000	11000

### Functional Data

Valve Size		Inches	3	4	6	8	10
		mm.	80	100	150	200	250
C <sub>v</sub> Factor	Globe Pattern	Gal./Min. (gpm.)	115	200	440	770	1245
		Litres/Sec. (l/s.)	27.6	48	105.6	184.8	299
	Angle Pattern	Gal./Min. (gpm.)	139	240	541	990	1575
		Litres/Sec. (l/s.)	33.4	58	130	238	378

## Pilot System Specifications

### Materials

#### Standard Pilot System Materials

Pilot Control: Bronze ASTM B61

Trim: Monel

Rubber: Buna-N® Synthetic Rubber

#### Optional Pilot System Materials

Pilot Systems are available with optional Stainless Steel or Monel materials at extra cost.

Note: Available with remote sensing control.

### Temperature Range

Water: to 180°F

### When Ordering, Please Specify

1. Catalog No. 414-01
2. Valve Size
3. Pattern - Globe or Angle
4. Pressure Class
5. Threaded, Flanged or Grooved
6. Trim Material
7. Adjustment Range
8. Desired Options
9. When Vertically Installed



E-414-01 (R-5/2011)

## CLA-VAL

1701 Placentia Avenue • Costa Mesa CA 92627

800-942-6326 • Fax: 949-548-5441 • Web Site: cla-val.com • E-mail: info@cla-val.com

**CLA-VAL CANADA**  
4687 Christie Drive  
Beamsville, Ontario  
Canada L0R 1B4  
Phone: 905-563-4863  
Fax: 905-563-4040  
E-mail sales@cla-val.ca

**CLA-VAL EUROPE**  
Chemin des Mésanges 1  
CH-1032 Romanel/  
Lausanne, Switzerland  
Phone: 41-21-643-15-55  
Fax: 41-21-643-15-50  
E-mail: cla-val@cla-val.ch

**CLA-VAL UK**  
Dainton House, Goods Station Road  
Tunbridge Wells  
Kent TN1 2 DH England  
Phone: 44-1892-514-400  
Fax: 44-1892-543-423  
E-mail: info@cla-val.co.uk

**CLA-VAL FRANCE**  
Porte du Grand Lyon 1  
ZAC du Champ du Périon  
France - 01700 Neyron  
Phone: 33-4-72-25-92-93  
Fax: 33-4-72-25-04-17  
E-mail: cla-val@cla-val.fr

**CLA-VAL PACIFIC**  
45 Kennaway Road  
Woolston, Christchurch, 8023  
New Zealand  
Phone: 64-39644860  
www.cla-valpacific.com  
E-mail: info@cla-valpacific.com

# Optional Pneumatic Control Arrangements

403-01

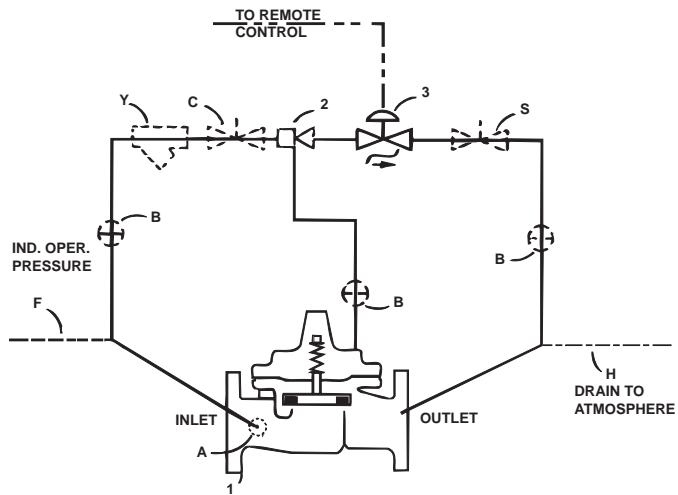

403-26

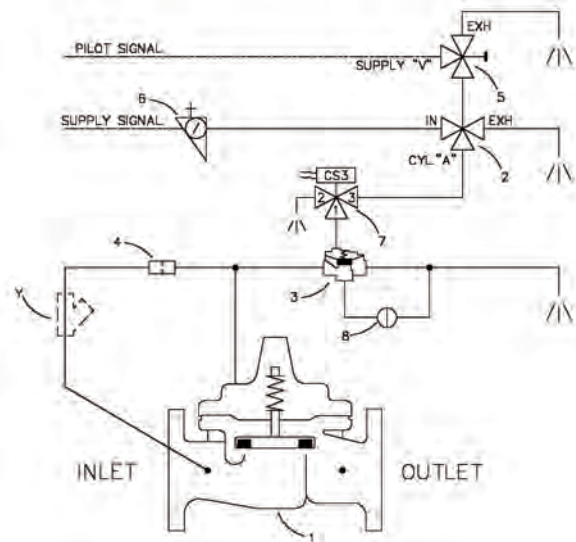

403-07

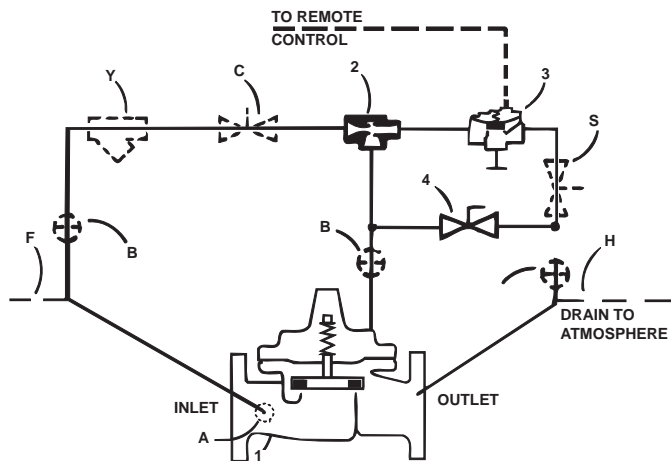

403-27

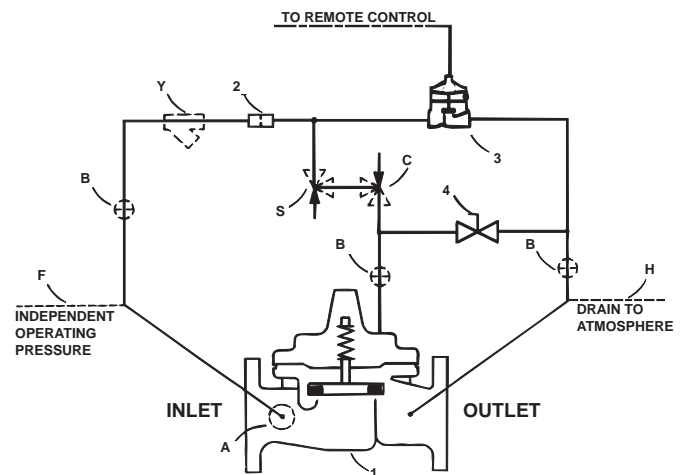

# Optional Pneumatic Control Arrangements

403-11

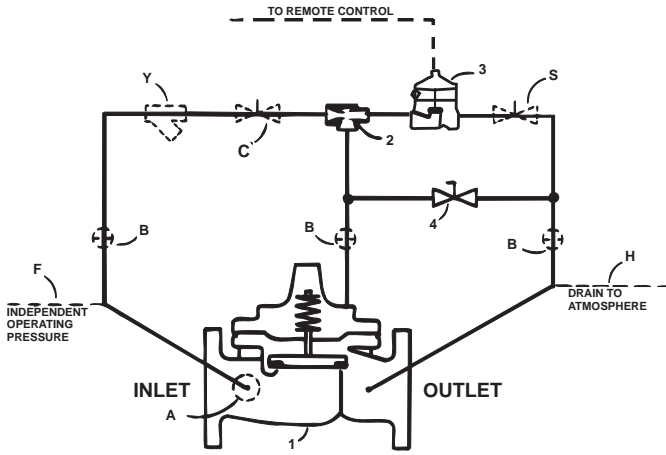

403-35

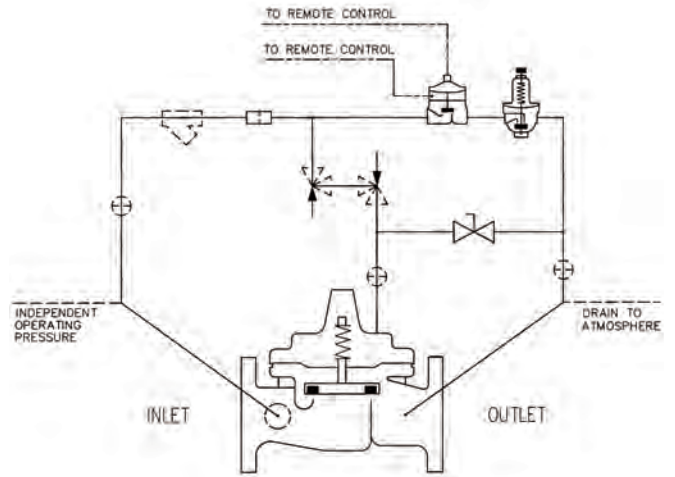

403-20

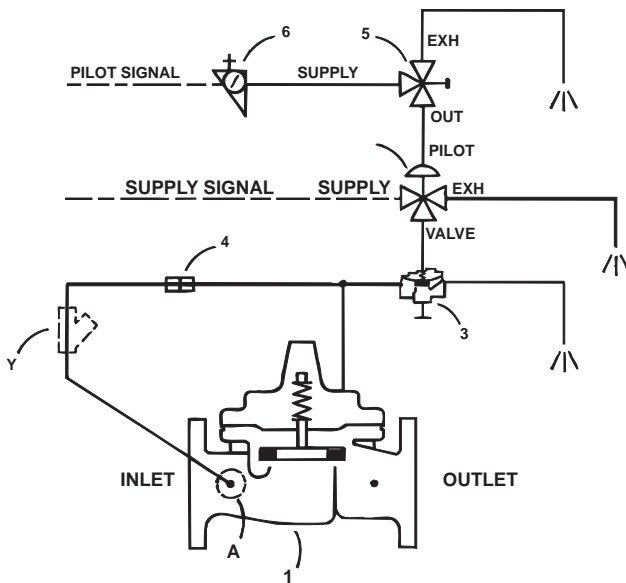

414-01

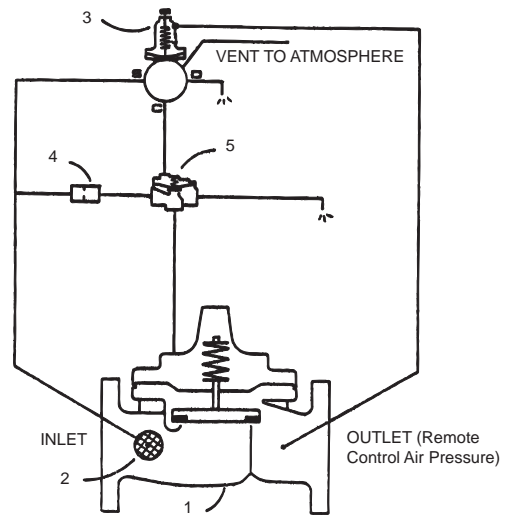



— MODEL — **210-01 (Full Internal Port)**  
**610-01 (Reduced Internal Port)**

## Altitude Valve for One-Way Flow

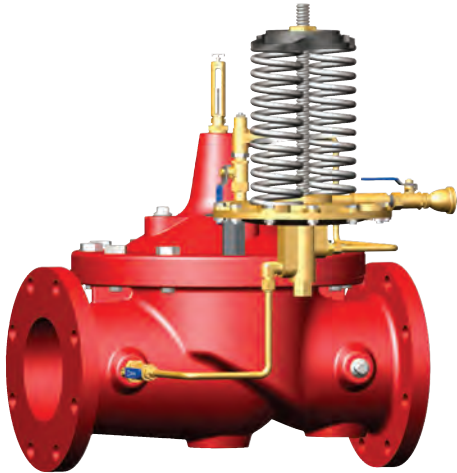

- **Accurate and Repeatable Level Control**
- **Drip-Tight, Positive Shut-Off**
- **Reliable Hydraulic Operation**
- **Easily Adjustable Control**
- **Completely Automatic Operation**

The Cla-Val Model 210-01/610-01 Altitude Valve controls the high water level in reservoirs without the need for floats or other devices. It is a non-throttling valve that remains fully open until the shut-off point is reached. This valve is designed for one-way flow only.

This valve is hydraulically operated and pilot controlled. The pilot control operates on the differential in forces between a spring load and the water level in the reservoir. The desired high water level is set by adjusting the spring force. The pilot control measures the reservoir head through a customer supplied sensing line\* connected directly to the reservoir.

This valve can also be furnished with auxiliary controls to meet the need for multiple functions, such as: pressure sustaining, pressure reduction, rate of flow control, solenoid override, etc.

If the check feature option is added and a pressure reversal occurs, the downstream pressure is admitted into the main valve cover chamber and the valve closes to prevent return flow.

### Schematic Diagram

Item	Description
1	Hytrol (Main Valve)
2	CDS6A Altitude Control
3	X101 Valve Position Indicator
4	Bell Reducer
5	CV Flow Control (Closing)

### Optional Features

Item	Description
A	X46A Flow Clean Strainer
B	CK2 (Isolation Valve)
D	Check Valve with Isolation Valve
F	Independent Operating Pressure
H	Dry Drain
P	X141 Pressure Gauge
R	Reservoir Gauge with Tester
S	CV Flow Control (Opening)
Y	X43 "Y" Strainer

\*3"-10" UL listed Main Valve available upon request.

Note: When "D" check feature is ordered, the "H" feature is required.

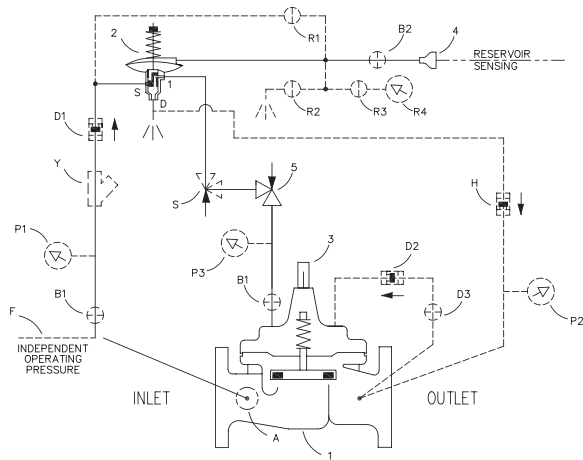

### Typical Applications

Used on reservoirs where the water is withdrawn through a separate line or through a bypass equipped with a check valve. The valve opens to refill the reservoir when the water lowers below the shut-off level. For more information see data sheet E-CDS6.

\*Note: The reservoir pressure sensing line should be 3/4" minimum I.D. installed with a 2° slope from the valve to the reservoir to avoid air pockets.

Note: We recommend protecting tubing and valve from freezing temperatures.

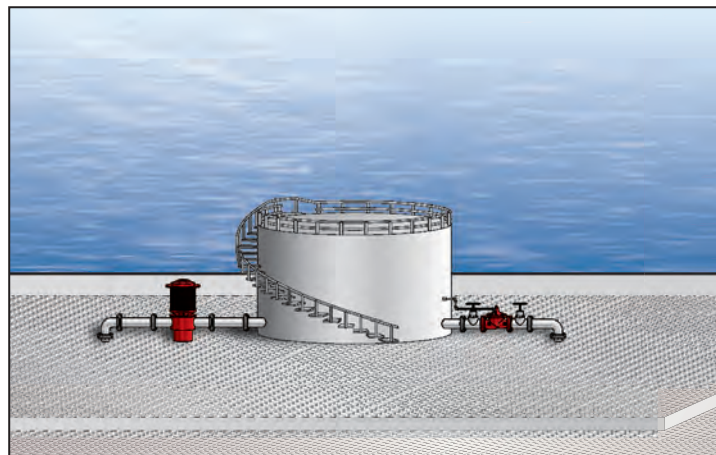

**Model 210-01** (Uses Basic Valve Model 100-01)

**Pressure Ratings** (Recommended Maximum Pressure - psi)

Valve Body & Cover		Pressure Class				
		Flanged			Grooved	Threaded
Grade	Material	ANSI Standards*	150 Class	300 Class	300 Class	End‡ Details
ASTM A536	Ductile Iron	B16.42	250	400	400	400
ASTM A216-WCB	Cast Steel	B16.5	285	400	400	400
ASTM B62	Bronze	B16.24	225	400	400	400

Note: \* ANSI standards are for flange dimensions only.  
 Flanged valves are available faced but not drilled.  
 ‡ End Details machined to ANSI B2.1 specifications.  
**Valves for higher pressure are available; consult factory for details**

**Materials**

Component	Standard Material Combinations		
Body & Cover	Ductile Iron	Cast Steel	Bronze
Available Sizes	2" - 36"	2" - 16"	2" - 16"
Disc Retainer & Diaphragm Washer	Cast Iron	Cast Steel	Bronze
Trim: Disc Guide, Seat & Cover Bearing	Bronze is Standard Stainless Steel is Optional		
Disc	Buna-N® Rubber		
Diaphragm	Nylon Reinforced Buna-N® Rubber		
Stem, Nut & Spring	Stainless Steel		
For material options not listed, consult factory. Cla-Val manufactures valves in more than 50 different alloys.			

**Dimensions**  
(In inches)

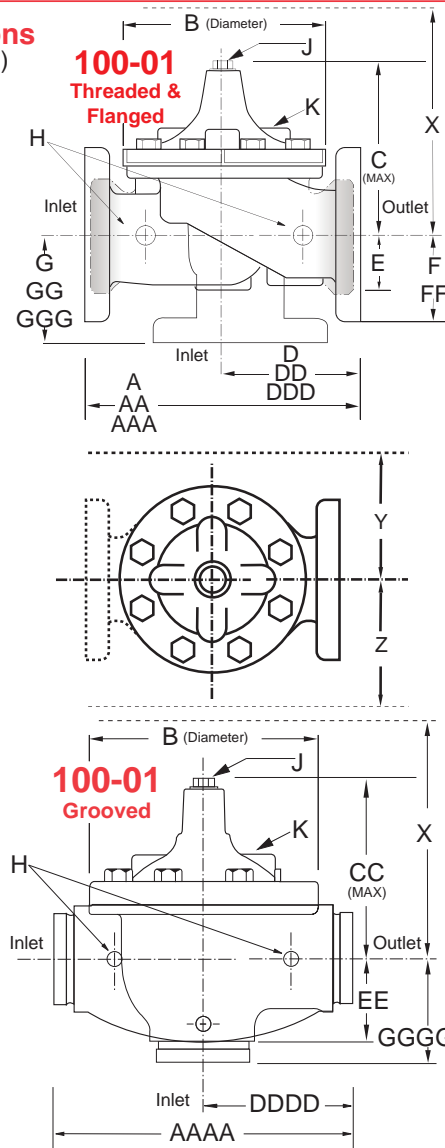

**Cover Capacity**

Liquid Volume Displaced from Diaphragm Chamber When Valve Opens or Closes

Valve Size	Displacement
2"	.032 gal
2 1/2"	.043 gal
3"	.080 gal
4"	.169 gal
6"	.531 gal
8"	1.26 gal
10"	2.51 gal
12"	4.00 gal
14"	6.50 gal
16"	9.57 gal
18"	9.57 gal
20"	12.00 gal
24"	29.00 gal
36"	42.00 gal

**Model 210-01 Dimensions** (In Inches)

Valve Size (Inches)	2	2 1/2	3	4	6	8	10	12	14	16	18	20	24	30	36
<b>A</b> Threaded	9.38	11.00	12.50	—	—	—	—	—	—	—	—	—	—	—	—
<b>AA</b> 150 ANSI	9.38	11.00	12.00	15.00	20.00	25.38	29.75	34.00	39.00	41.38	46.00	52.00	61.50	63.00	76.00
<b>AAA</b> 300 ANSI	10.00	11.62	13.25	15.62	21.00	26.38	31.12	35.50	40.50	43.50	47.64	53.62	63.24	64.50	76.00
<b>AAAA</b> Grooved End	9.00	11.00	12.50	15.00	20.00	25.38	—	—	—	—	—	—	—	—	—
<b>B</b> Dia.	6.62	8.00	9.12	11.50	15.75	20.00	23.62	28.00	32.75	35.50	41.50	45.00	53.16	56.00	66.00
<b>C</b> Max.	6.50	7.56	8.19	10.62	13.38	16.00	17.12	20.88	24.19	25.00	39.06	41.90	43.93	54.60	61.50
<b>CC</b> Max. Grooved End	5.75	6.88	7.25	9.31	12.12	14.62	—	—	—	—	—	—	—	—	—
<b>D</b> Threaded	4.75	5.50	6.25	—	—	—	—	—	—	—	—	—	—	—	—
<b>DD</b> 150 ANSI	4.75	5.50	6.00	7.50	10.00	12.69	14.88	17.00	19.50	20.81	—	—	30.75	—	—
<b>DDD</b> 300 ANSI	5.00	5.88	6.38	7.88	10.50	13.25	15.56	17.75	20.25	21.62	—	—	31.62	—	—
<b>DDDD</b> Grooved End	4.75	—	6.00	7.50	—	—	—	—	—	—	—	—	—	—	—
<b>E</b>	1.50	1.69	2.06	3.19	4.31	5.31	9.25	10.75	12.62	15.50	12.95	15.00	17.75	21.31	24.56
<b>EE</b> Grooved End	2.50	2.88	3.12	4.25	6.00	7.56	—	—	—	—	—	—	—	—	—
<b>F</b> 150 ANSI	3.00	3.50	3.75	4.50	5.50	6.75	8.00	9.50	10.50	11.75	15.00	16.50	19.25	22.50	25.60
<b>FF</b> 300 ANSI	3.25	3.75	4.13	5.00	6.25	7.50	8.75	10.25	11.50	12.75	15.00	16.50	19.25	24.00	25.60
<b>G</b> Threaded	3.25	4.00	4.50	—	—	—	—	—	—	—	—	—	—	—	—
<b>GG</b> 150 ANSI	3.25	4.00	4.00	5.00	6.00	8.00	8.62	13.75	14.88	15.69	—	—	22.06	—	—
<b>GGG</b> 300 ANSI	3.50	4.31	4.38	5.31	6.50	8.50	9.31	14.50	15.62	16.50	—	—	22.90	—	—
<b>GGGG</b> Grooved End	3.25	—	4.25	5.00	—	—	—	—	—	—	—	—	—	—	—
<b>H</b> NPT Body Tapping	.375	.50	.50	.75	.75	1	1	1	1	1	1	1	1	2	2
<b>J</b> NPT Cover Center Plug	.50	.50	.50	.75	.75	1	1	1.25	1.5	2	1.5	1.5	1.5	2	2
<b>K</b> NPT Cover Tapping	.375	.50	.50	.75	.75	1	1	1	1	1	1	1	1	2	2
Stem Travel	0.6	0.7	0.8	1.1	1.7	2.3	2.8	3.4	4.0	4.5	5.1	5.63	6.75	7.5	8.5
Approx. Ship Wt. Lbs.	35	50	70	140	285	500	780	1165	1600	2265	2982	3900	6200	7703	11720
<b>X</b> Pilot System	13	14	15	17	29	31	33	36	40	40	43	47	68	79	85
<b>Y</b> Pilot System	9	10	11	12	20	22	24	26	29	30	32	34	39	40	45
<b>Z</b> Pilot System	9	10	11	12	20	22	24	26	29	30	32	34	39	42	47

Note: The top two flange holes on valve size 36 are threaded to 1 1/2"-6 UNC.

**Model 610-01** (Uses Basic Valve Model 100-20)

**Dimensions**  
(In inches)

**Pressure Ratings** (Recommended Maximum Pressure - psi)

Valve Body & Cover		Pressure Class		
		Flanged		
Grade	Material	ANSI Standards*	150 Class	300 Class
ASTM A536	Ductile Iron	B16.42	250	400
ASTM A216-WCB	Cast Steel	B16.5	285	400
ASTM B62	Bronze	B16.24	225	400

Note: \* ANSI standards are for flange dimensions only.  
Flanged valves are available faced but not drilled.  
**Valves for higher pressure are available; consult factory for details**

**Cover Capacity**  
Liquid Volume Displaced from Diaphragm Chamber When Valve Opens or Closes

Valve Size	Displacement
3"	.032 gal
4"	.080 gal
6"	.169 gal
8"	.531 gal
10"	1.26 gal
12"	2.51 gal
14"	2.51 gal
16"	4.00 gal
18"	4.00 gal
20"	9.57 gal
24"	9.57 gal
30"	29.00 gal

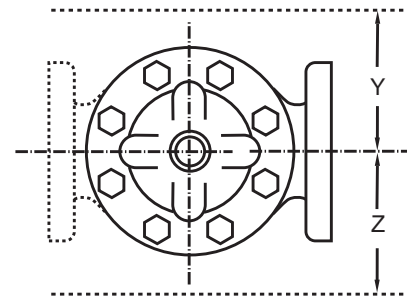
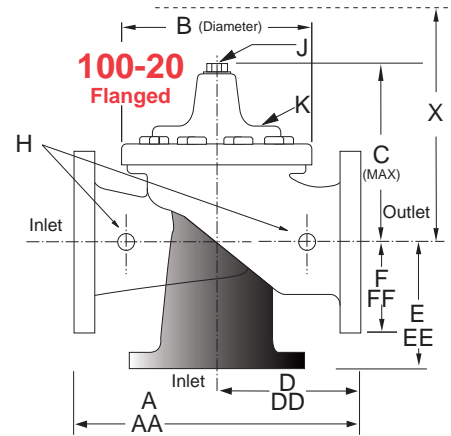

**Materials**

Component	Standard Material Combinations		
Body & Cover	Ductile Iron	Cast Steel	Bronze
Available Sizes	3" - 48"	3" - 16"	3" - 16"
Disc Retainer & Diaphragm Washer	Cast Iron	Cast Steel	Bronze
Trim: Disc Guide, Seat & Cover Bearing	Bronze is Standard Stainless Steel is Optional		
Disc	Buna-N® Rubber		
Diaphragm	Nylon Reinforced Buna-N® Rubber		
Stem, Nut & Spring	Stainless Steel		

For material options not listed, consult factory.  
Cla-Val manufactures valves in more than 50 different alloys.

**Model 610-01 Dimensions** (In Inches)

Valve Size (Inches)	3	4	6	8	10	12	14	16	18	20	24	30	36	42	48
A 150 ANSI	10.25	13.88	17.75	21.38	26.00	30.00	34.25	35.00	42.12	48.00	48.00	63.25	65.00	76.00	94.50
AA 300 ANSI	11.00	14.50	18.62	22.38	27.38	31.50	35.75	36.62	43.63	49.62	49.75	63.75	67.00	76.00	94.50
B Dia.	6.62	9.12	11.50	15.75	20.00	23.62	27.47	28.00	35.44	35.44	35.44	53.19	56.00	66.00	66.00
C Max.	7.00	8.62	11.62	15.00	17.88	21.00	20.88	25.75	25.00	31.00	31.00	43.94	54.60	61.50	61.50
D 150 ANSI	—	6.94	8.88	10.69	CF*	CF*	CF*	CF*	CF*	CF*	CF*	—	—	—	—
DD 300 ANSI	—	7.25	9.38	11.19	CF*	CF*	CF*	CF*	CF*	CF*	CF*	—	—	—	—
E 150 ANSI	—	5.50	6.75	7.25	CF*	CF*	CF*	CF*	CF*	CF*	CF*	—	—	—	—
EE 300 ANSI	—	5.81	7.25	7.75	CF*	CF*	CF*	CF*	CF*	CF*	CF*	—	—	—	—
F 150 ANSI	3.75	4.50	5.50	6.75	8.00	9.50	11.00	11.75	15.88	14.56	17.00	19.88	25.50	28.00	31.50
FF 300 ANSI	4.12	5.00	6.25	7.50	8.75	10.25	11.50	12.75	15.88	16.06	19.00	22.00	27.50	28.00	31.50
H NPT Body Tapping	.375	.50	.75	.75	1	1	1	1	1	1	1	1	2	2	2
J NPT Cover Center Plug	.50	.50	.75	.75	1	1	1.25	1.25	2	2	2	2	2	2	2
K NPT Cover Tapping	.375	.50	.75	.75	1	1	1	1	1	1	1	1	2	2	2
Stem Travel	0.6	0.8	1.1	1.7	2.3	2.8	3.4	3.4	4.5	4.5	4.5	6.5	7.5	8.5	8.5
Approx. Ship Wt. Lbs.	45	85	195	330	625	900	1250	1380	1500	2551	2733	6500	8545	12450	13100
X Pilot System	13	15	27	30	33	36	36	41	40	46	55	68	79	85	86
Y Pilot System	10	11	18	20	22	24	26	26	30	30	30	39	40	45	47
Z Pilot System	10	11	18	20	22	24	26	26	30	30	30	39	42	47	49

\*Consult Factory

Note: The top two flange holes on valve sizes 36 thru 48 are threaded to 1 1/2"-6 UNC.

<b>210-01</b> <b>Valve Selection</b>	<b>100-01 Pattern:</b> Globe (G), Angle (A), <b>End Connections:</b> Threaded (T), Grooved (GR), Flanged (F) Indicate Available Sizes															
	Inches	2	2½	3	4	6	8	10	12	14	16	18	20	24	30	36
	mm	50	65	80	100	150	200	250	300	350	400	450	500	600	750	900
Basic Valve 100-01	Pattern	G, A	G, A	G, A	G, A	G, A	G, A	G, A	G, A	G, A	G, A	G	G	G, A	G	G
	End Detail	T, F, Gr	T, F, Gr*	T, F, Gr	F, Gr	F, Gr*	F, Gr*	F	F	F	F	F	F	F	F	F
Suggested Flow (gpm)	Maximum	210	300	460	800	1800	3100	4900	7000	8400	11000	14000	17000	25000	42000	50000
	Maximum Intermittent	260	370	580	990	2250	3900	6150	8720	10540	13700	17500	21700	31300	48000	62500
Suggested Flow (Liters/Sec)	Maximum	13	19	29	50	113	195	309	442	530	694	883	1073	1577	2650	3150
	Maximum Intermittent	16	23	37	62	142	246	387	549	664	863	1104	1369	1972	3028	3940
<b>100-01 Series is the full internal port Hytrol.</b>																
*Globe																

<b>610-01</b> <b>Valve Selection</b>	<b>100-20 Pattern:</b> Globe (G), Angle (A), <b>End Connections:</b> Flanged (F) Indicate Available Sizes															
	Inches	3	4	6	8	10	12	14	16	18	20	24	30	36	42	48
	mm	80	100	150	200	250	300	350	400	450	500	600	750	900	1000	1200
Basic Valve 100-20	Pattern	G	G, A	G, A	G, A	G	G	G	G	G	G	G	G	G	G	G
	End Detail	F	F	F	F	F	F	F	F	F	F	F	F	F	F	F
Suggested Flow (gpm)	Maximum	260	580	1025	2300	4100	6400	9230	9230	16500	16500	16500	28000	33500	33500	33500
Suggested Flow (Liters/Sec)	Maximum	16	37	65	145	258	403	581	581	1040	1040	1040	1764	2115	2115	2115
<b>100-20 Series is the reduced internal port size version of the 100-01 Series.</b>																

## Pilot System Specifications

### Adjustment Ranges

- 5 - 40 ft.
- 30 - 80 ft.
- 70 - 120 ft.
- 110 - 160 ft.
- 150 - 200 ft.

### Temperature Range

Water: to 180°F

If flowing line pressure is less than 10 psi, consult factory for full details.

If inlet pressure is above 150 psi, consult factory for recommendations.

### Materials

#### Standard Pilot System Materials

- Pilot Control: Bronze ASTM B62
- Trim: Stainless Steel Type 303
- Rubber: Buna-N® Synthetic Rubber

#### Optional Pilot System Materials

Pilot Systems are available with optional Aluminum, Stainless Steel, or Monel materials.

Valve position indicator is standard.

## When Ordering, Please Specify

1. Catalog No. 210-01 or No. 610-01
2. Valve Size
3. Pattern - Globe or Angle
4. Pressure Class
5. Threaded or Flanged
6. Materials Desired
7. Adjustment Range
8. Desired Options
9. When Vertically Installed
10. When "D" feature is ordered, the "H" feature is required.



E-210-01/610-01 (R-5/2015)

## CLA-VAL

1701 Placentia Avenue • Costa Mesa CA 92627  
800-942-6326 • Fax: 949-548-5441 • Web Site: [cla-val.com](http://cla-val.com) • E-mail: [info@cla-val.com](mailto:info@cla-val.com)

#### CLA-VAL CANADA

4687 Christie Drive  
Beamsville, Ontario  
Canada L0R 1B4  
Phone: 905-563-4963  
Fax: 905-563-4040  
E-mail: [sales@cla-val.ca](mailto:sales@cla-val.ca)

#### CLA-VAL EUROPE

Chemin des Mésanges 1  
CH-1032 Romanel/  
Lausanne, Switzerland  
Phone: 41-21-643-15-55  
Fax: 41-21-643-15-50  
E-mail: [cla-val@cla-val.ch](mailto:cla-val@cla-val.ch)

#### CLA-VAL UK

Dainton House, Goods Station Road  
Tunbridge Wells  
Kent TN11 2 DH England  
Phone: 44-1892-514-400  
Fax: 44-1892-543-423  
E-mail: [info@cla-val.co.uk](mailto:info@cla-val.co.uk)

#### CLA-VAL FRANCE

Porte du Grand Lyon 1  
ZAC du Champ du Périer  
France - 01700 Neyron  
Phone: 33-4-72-25-92-93  
Fax: 33-4-72-25-04-17  
E-mail: [cla-val@cla-val.fr](mailto:cla-val@cla-val.fr)

#### CLA-VAL PACIFIC

45 Kennaway Road  
Woolston, Christchurch, 8023  
New Zealand  
Phone: 64-39644860  
[www.cla-valpacific.com](http://www.cla-valpacific.com)  
E-mail: [info@cla-valpacific.com](mailto:info@cla-valpacific.com)

©COPYRIGHT CLA-VAL 2018 Printed in USA Specifications subject to change without notice.



# Series 33A

Sizes 1" - 2" - 3" - 4" - 6"

## High Performance Combination Air Release & Vacuum Breaker Valve



Threaded



Flanged

- Automatically Eliminates Air Pockets
- Easily Serviced Without Removal from Pipeline
- Simple, Effective Patented Design
- Corrosion Resistant Materials of Construction
- Engineered For Lasting Service

Designed to protect pipelines and vertical turbine pump applications on offshore platforms from air lock and vacuum collapse, the Cla-Val Model 33A Combination Air Release and Vacuum Breaker Valve eliminates air and prevents vacuum formations in pipelines. A large venting orifice and large float clearances freely exhaust or admits air during pipeline filling or draining.

During normal pipeline operation, air accumulation and buoyancy cause the float ball to lower or lift. As the water level lowers inside the valve, small amounts of accumulated air are released through the small orifice. Once air is released, the patented float poppet system closes drip tight.

Valve servicing is simple because the entire float poppet system, can be replaced without removal of the valve body from the pipeline.

### Typical Applications

- Standard Max. D.W.P. 300 psi (For Higher Operating Pressures Consult Factory)
- Transmission Pipeline High Points
- Water Treatment Plant Piping High Points
- Offshore Platforms
- Vertical Turbine Pump Discharge

### Installation

Series 33A Combination Air Release and Vacuum Breaker Valves are typically installed at high points in pipelines for air release, or at anticipated pipeline vacuum occurrence locations. Install Series 33A at regular intervals (approximately 1/2 mile) along uniform grade line pipe. Mount the unit in the vertical position on top of the pipeline, and include an isolation/shutoff valve.

Series 33A is often installed upstream of check valves in pump discharges to vent air during start-up and to allow air reentry when the pump stops.

### Operation

#### Air Release Mode—Valve is normally open.

When line is filled or pump started, air is exhausted through the normally open 33A valve. As liquid fills the valve, float ball rises to form a drip-tight closure and remaining air is exhausted through small orifice.

**Vacuum Prevent Mode** When line pressure drops below positive pressure and the liquid level lowers, the float drops, unseating the valve and allowing air into the line, thus preventing a vacuum.

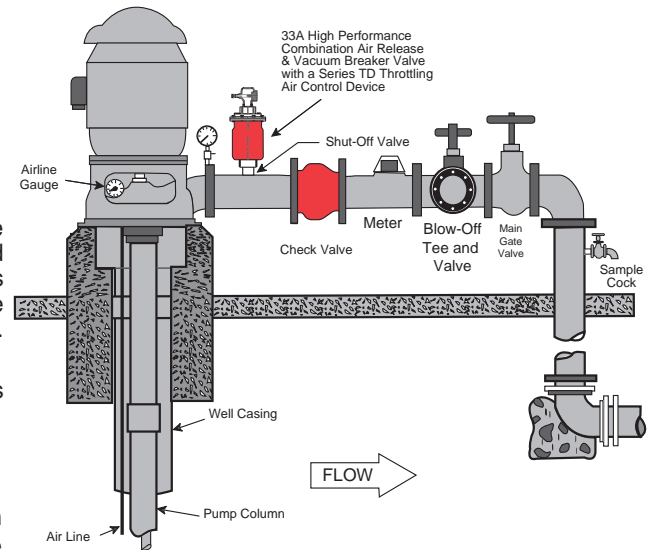

**Note:** Available for Sea Water Service See Material Specifications

## Dimensions (In Inches)

## MODEL 33A - 1", 2", 3", 4" and 6" Sizes

Valve Size	33A Pressure Class 300 Lb Threaded				33A Pressure Class 150 Lb Flanged (INLET)			
	1"	2"	3"	4"	2"	3"	4"	6"
A	9.10	12.44	12.75	12.75	13.88	15.56	15.75	16.38
B	6.25	7.50	9.00	9.00	7.50	9.25	9.25	11.00
E	—	—	—	—	.62	.75	.94	1.00
Inlet (ANSI)	1" NPT	2" NPT	3" NPT	4" NPT	2"	3"	4"	6"
Outlet (NPT)	1" NPT	2" NPT	3" NPT	4" NPT	2"	3"	4"	6"
Number of Holes	—	—	—	—	4	4	8	8
Diameter of Bolts	—	—	—	—	.63	.63	.75	.75
Shipping Wt. (Lb.)	25	29	38	40	39	48	50	70

### Pressure Ratings

Valve Size	Orifice Dia.	Standard Maximum Pressure	Materials of Construction
1"	.076"	300 psi	<ul style="list-style-type: none"> <li>Ductile Iron ASTM A536 65-45-12</li> <li>Epoxy Coated Cast Steel ASTM A 216WCB</li> </ul>
2"	.076"	500 psi	
3" & 4"	.125"	300 psi	<ul style="list-style-type: none"> <li>ASTM B61 Naval Bronze</li> <li>ASTM B 148 NI Aluminum Bronze</li> <li>316 Stainless Steel</li> </ul>
3" & 4"	.076"	300 psi	
6"	.076"	300 psi	<ul style="list-style-type: none"> <li>Duplex Stainless Steel</li> <li>Super Duplex Stainless Steel</li> </ul>

**Note:** Higher Pressures Available upon Request

### Specifications

#### Standard Internals

Float: Stainless Steel 304SS Standard, T316 or Monel optional (extra cost)

Balance internals parts Stainless Steel and Delrin

Seals Nitrile Rubber or Viton® (extra cost)

#### Temperature Range

Water to 180° F

#### Optional:

1. Fusion epoxy lined and coated
2. For Well Service Throttling Device on the Outlet Specify Model TD

### When Ordering, Please Specify

1. Catalog No.
2. Valve Size
3. Pressure Rating
4. Materials

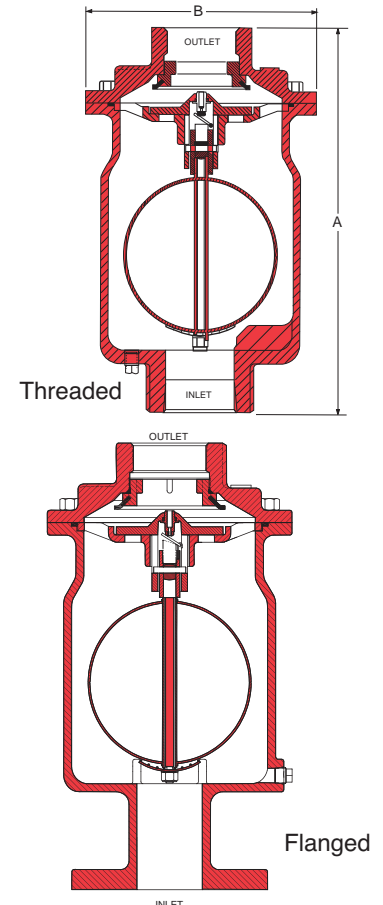

### Valve Sizing Selection

#### Large Orifice Air-Vacuum Capacity

Determine anticipated water flow and allowable pressure differential for the pipeline application. Select valve from chart to exhaust or admit air at the same rate as water filling or draining (in CFS). For larger flows, two or more Model 33A's may be installed in parallel

#### Large Orifice

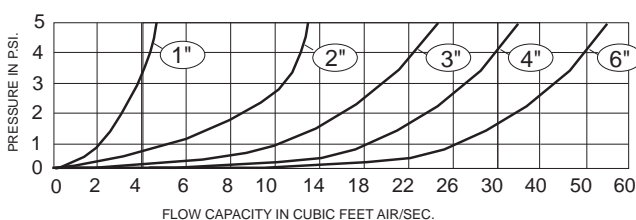

Note: For sizing made easy request:  
Cla-Val Selector Slide Rule

#### Small Orifice Capacity

During pressurized pipeline operation, small pockets of entrapped air will be released through the float actuated 0.076 or .125 inch orifice. Use chart to determine discharge capacity.

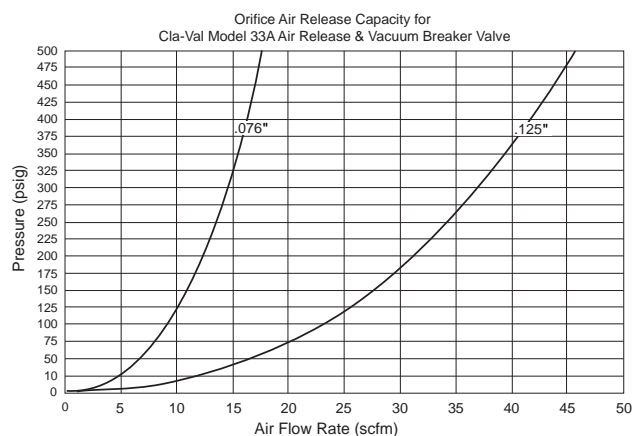



# Series 33B

Sizes 1" - 2"

## High Performance Combination Air Release & Vacuum Breaker Valve with Non-Surge Orifice



Flanged Inlet Available

- Sizes 1" - 2"
- Automatically Protects Pipelines
- Easily Serviced Without Removal from Pipeline
- Pressure Sensitive Closing Orifice
- Corrosion Resistant Internal Parts
- Engineered For Lasting Service

Designed to protect pipelines from air lock and vacuum collapse, the Cla-Val Model 33B Air Release and Vacuum Breaker Valve eliminates air and prevents vacuum formations in pipelines. A large venting orifice and large float clearances freely exhaust or admits air during pipeline filling or draining.

During normal pipeline operation, air accumulation and buoyancy cause the float ball to lower or lift. As the water level lowers inside the valve, small amounts of accumulated air are released through the small orifice. Once air is released, the patented float poppet system closes drip tight.

Valve servicing is simple because the entire float poppet system, can be replaced without removal of the valve body from the pipeline.

### Typical Applications

- Water Transmission Pipeline High Points
- Water Treatment Plant Piping High Points
- Vertical Turbine Pump Discharge

### Installation

Series 33B Air Release and Vacuum Breaker Valves are typically installed at high points in pipelines for air release, or at anticipated pipeline vacuum occurrence locations. Install Series 33B at regular intervals (approximately 1/2 mile) along uniform grade line pipe. Mount the unit in the vertical position on top of the pipeline, and include an isolation/shutoff valve.

Series 33B is often installed upstream of check valves in pump discharges to vent air during start-up and to allow air reentry when the pump stops.

### Operation

#### Air Release Mode—Valve is normally open.

When line is filled or pump started, air is exhausted through the normally open 33B valve. With excessive air exhaust, the non-surge orifice closes. Air will continue to be exhausted through the non-surge orifice disc. The non-surge float prevents the slam effect and therefore suppresses water hammer.

As liquid fills the valve, float ball rises to form a drip-tight closure and remaining air is exhausted through small orifice.

**Vacuum Prevent Mode** When line pressure drops below positive pressure and the liquid level lowers, the float drops, unseating the valve and allowing air into the line, thus preventing a vacuum.

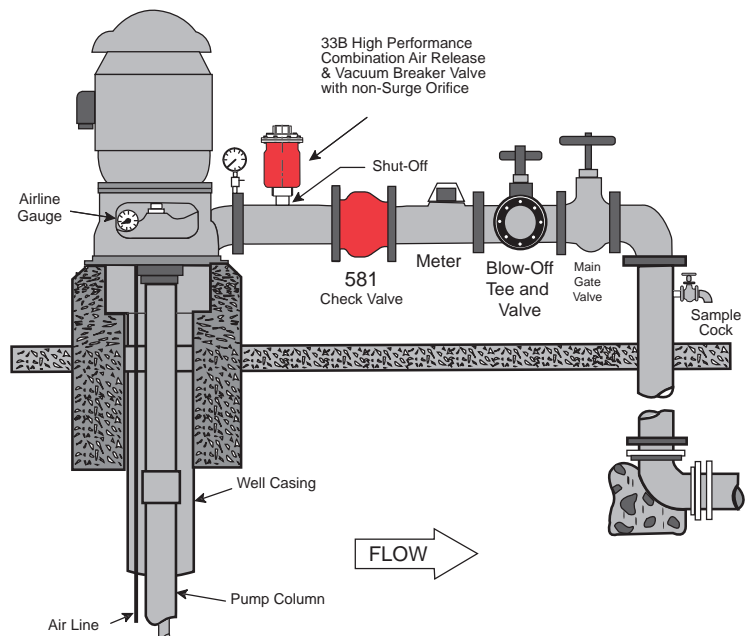

## Specifications

### MODEL 33B - 1", 2" SIZES

### Single Body Combination Air Vacuum and Air Release Valve

#### Pressure Ratings

500 psi

500 psi

600 psi

#### Materials

Body and Cover: Ductile Iron ASTM A536 65-45-12

Body and Cover: Stainless Steel T316

Body and Cover: Cast Steel ASTM A 216 WCB

#### Seawater Service Materials:

Bronze readily available for seawater service and other corrosive fluids applications Made of:

Monel - Bronzes (ASTM B61 or ASTM B148) - 316 Stainless Steel

#### Standard Internals:

Bronzes ASTM B61 or ASTM B148

Monel / 316 Stainless Steel

Duplex Stainless Steel UNS S31803

Super Duplex Stainless Steel ASTM A890-5A UNS J93404

Super Austenitic Stainless Steel 6MO UNS S31254

Titanium ASTM B367 Gr 2

#### Standard Internals:

Float: Delrin

Seals Nitrile Rubber or Viton (extra cost)

#### Temperature Range

Water to 180° F

#### Optional:

1. For Well Service use 33C Type

## Dimensions (In Inches)

Valve Size	1"	2"
A	9.10	12.44
B	6.25	7.50
Inlet (NPT)	1" NPT	2" NPT
Outlet (NPT)	1" NPT	2" NPT
Shipping Wt. (Lbs.)*	25	29
Max. Operating PSI (Std. Orifice)	300	500
Max. Operating PSI (with .076 Orifice)	300	500

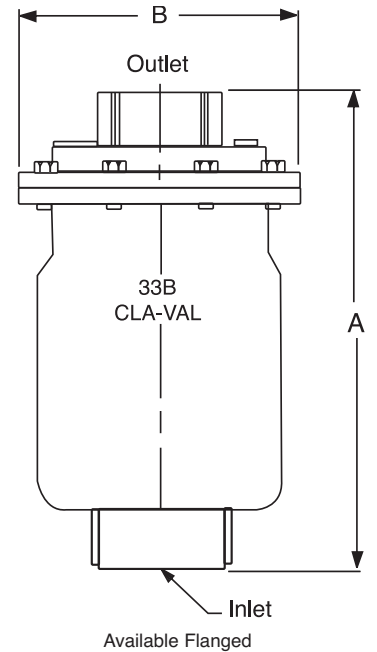

### When Ordering, Please Specify

1. Catalog No.
2. Valve Size
3. Pressure Rating
4. Materials

## Valve Sizing Selection

### Air-Vacuum Capacity

Determine anticipated water flow and allowable pressure differential for the pipeline application. Select valve from chart to exhaust or admit air at the same rate as water filling or draining (in CFS). For larger flows, two or more Model 33B's may be installed in parallel

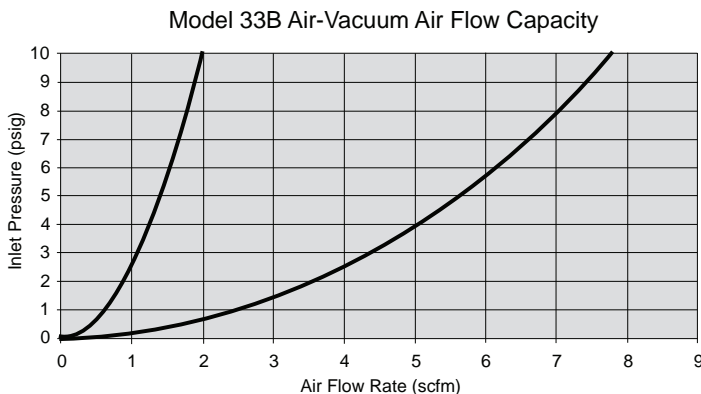

### Small Orifice Capacity

During pressurized pipeline operation, small pockets of entrapped air will be released through the float actuated 0.076 or .125 inch orifice. Use chart to determine discharge capacity.

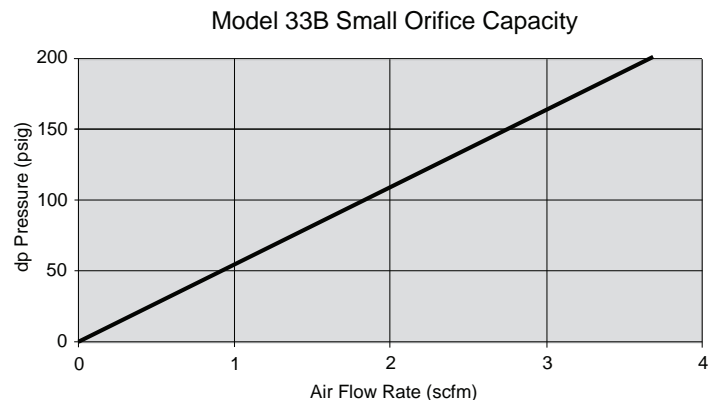



— MODEL — **33ATD**  
 Sizes 2" - 3" - 4"

## Air Release & Vacuum Breaker Valve (Threaded & Flanged) with Throttling Air Control Device



Flanged Inlet shown  
 Threaded Inlet also available

- Automatically eliminates air pockets
- Easily serviced without removal from pipeline
- Simple, effective patented design
- Corrosion resistant internal parts
- Engineered for lasting service
- Sizes 2", 3" and 4" UL Listed

Designed to protect pipelines from air lock and vacuum collapse, the CLA-VAL Model 33ATD Air Release and Vacuum Breaker Valve eliminates air and prevents vacuum formation in pipelines. A large venting orifice and large float clearances freely exhaust or admits air during pipeline filling or draining.

During normal pipeline operation, air accumulation and buoyancy cause the floats to lower or lift. As the water level lowers inside the valve, small amounts of accumulated air are released through the small orifice. Once air is released, the patented float poppet system closes drip tight.

Valve servicing is simple because the entire float poppet system, can be replaced without removal of the valve body from the pipeline.

### Installation

Series 33ATD is often installed upstream of check valves in vertical pump discharges to throttle air out during start-up and to allow full air reentry when the pump stops.

### Operation

#### Air Release Mode - Valve is normally open:

When line is filled or pump started, air is throttled through the air control device TD. As liquid fills the valve, float ball rises to form a drip-tight closure and remaining air is exhausted through small orifice. Air throttling can be adjusted by means of adjusting the screw.

#### Vacuum Prevent Mode:

When line pressure drops below positive pressure and the liquid level lowers, the float drops, unseating the valve and allowing air into the line, thus preventing a vacuum. The spring loaded disc in the TD throttling air control device is moved to the air intake position due to the negative pressure.

### Typical Applications

- Standard Max. D.W.P. 300 psi for UL Listed assemblies (for Higher Operating Pressure Consult Factory)
- Transmission pipeline high points
- Water treatment plant piping high points
- Offshore platforms
- Vertical turbine pump discharge

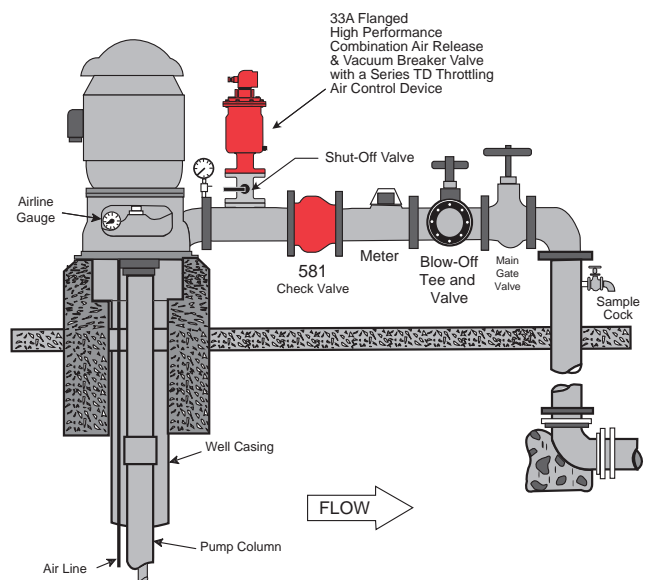

**Note:** Available for Sea Water Service (see material specifications)

visit [www.cla-val.com](http://www.cla-val.com) to learn  
 about our complete line of  
 fire protection products.

## Dimensions (In Inches)

## MODEL 33ATD - 2", 3", and 4" Sizes

Valve Size	33A Pressure Class 300 Lb Threaded				33A Pressure Class 150 Lb Flanged (INLET)			33A Pressure Class 300 Lb Flanged (INLET)		
	1"*	2"	3"	4"	2"	3"	4"	2"	3"	4"
A	11.81	16.50	18.50	20.00	17.75	21.75	23.50	18.00	22.00	23.75
B	4.13	7.50	9.25	9.25	7.50	9.25	9.25	7.50	9.25	9.25
Inlet (ANSI)	1" NPT	2" NPT	3" NPT	4" NPT	2"	3"	4"	2"	3"	4"
Outlet (NPT)	1" NPT	2" NPT	3" NPT	4" NPT	2" NPT	3" NPT	4" NPT	4" NPT	3" NPT	4" NPT
Number of Holes	—	—	—	—	4	4	8	8	8	8
Diameter of Bolts	—	—	—	—	.625	.625	.625	0.75	0.75	0.75
Approximate calculated shipping weight (lb.)	25	29	38	40	39	48	50	41	55	58

\* 1" size is not UL Listed. Consult Factory for other available end options.

### Pressure Ratings

Valve Size	Orifice Dia.	Standard Maximum Pressure
1"	.076"	300 psi
2"	.076"	500 psi
3" & 4"	.125"	300 psi
3" & 4"	.076"	450 psi

**Note:** Maximum Pressure Rating for UL Listed 33ATD = 300 psi

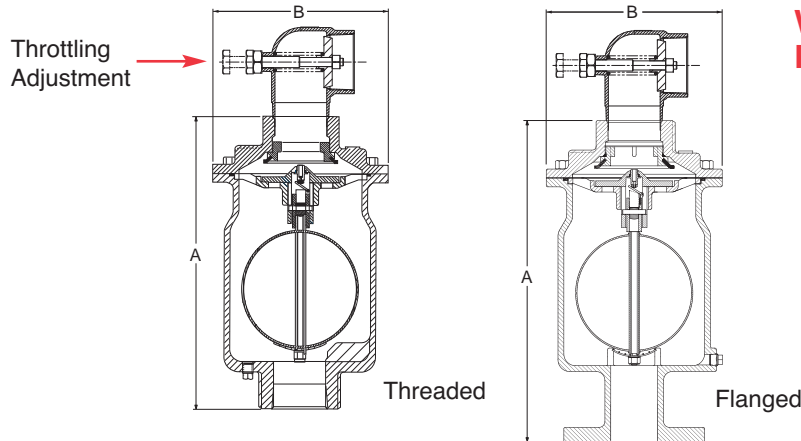

### When Ordering, Please Specify

1. Catalog No.
2. Valve Size
3. Pressure Rating
4. Materials

## Specifications

### Standard Internals

**Float:** Stainless Steel 304SS Standard, T316 or Monel optional (extra cost)

Balance internal parts Stainless Steel and Delrin

Seals Nitrile Rubber or Viton® (extra cost)

**Note:** Fluorocarbon is not a UL Listed Seal Material

**Temperature Range:** Water to 180° F

### Optional:

Fusion epoxy lined and coated

For well service throttling device on the outlet specify model TD

### Materials of Construction

- Nickel Aluminum Bronze (NAB) - ASTM B148 Alloy C95800
- Monel - QQ-N-288 Comp B - ASTM A494 Grade M30H
- Cast Steel - ASTM A216 Grade WCB
- 316 Stainless Steel - ASTM A743 Grades CF3M and CFM8
- Super Austenitic Stainless Steel - ASTM A351 Grade CK3MCuN (SMO 254)
- Super Duplex Stainless Steel - ASTM A890 Grade 5A (CE3MN)

## Valve Sizing Selection

### Air-Vacuum Flow Capacity

Determine anticipated water flow and allowable pressure differential for the pipeline application. Select valve from chart to exhaust or admit air at the same rate as water filling or draining (in CFS). For larger flows, two or more Model 33ATD's may be installed in parallel

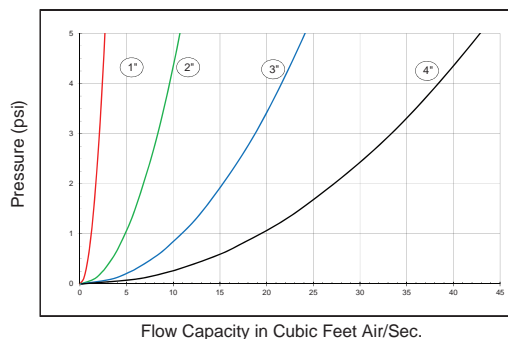

### Air Release Capacity

During pressurized pipeline operation, small pockets of entrapped air will be released through the float actuated 0.076 or .125 inch orifice. Use chart to determine discharge capacity.

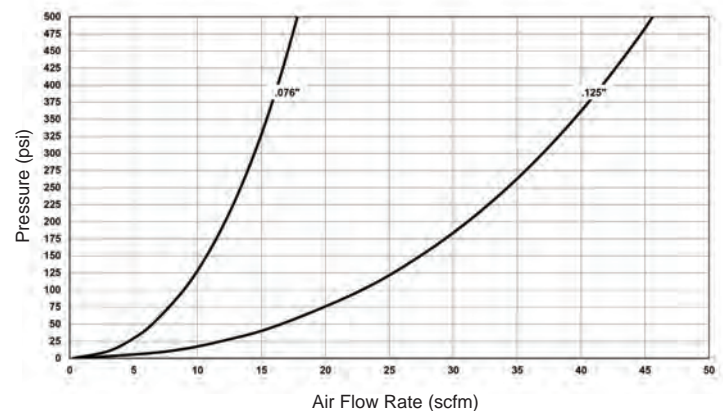



# Series 580

## Silent Wafer Check Valve



### Product Advantages

- Operates Horizontally or Vertically
- Watertight Metal-to-Metal Seating
- Field Replaceable Parts
- Factory Mutual Approved – 4 through 10-inches
- Optional Resilient Seat

The Cla-Val Series 580 Silent Wafer Check Valve has a spring-loaded poppet that allows the valve to close before flow reversal occurs, resulting in a silent, non-slam closure. It is a truly silent check valve. For ease of installation, the valve can be installed in vertical or horizontal positions with flow up or flow down. The short lay length of the valve allows for a space-saving design. Silent Wafer Check Valves are available in sizes 1" to 10", with either a 125/150# or 250/300# pressure class rating.

Constructed of an epoxy coated ductile iron body with stainless steel trim, the Cla-Val Silent Wafer Check Valve offers watertight shutoff with metal-to-metal seating. For special applications, Buna-N® resilient seats are available as options. All materials conform to ASTM specifications, ensuring long lasting reliable performance. As a confirmation of Cla-Val's commitment to quality, all Series 580 125/250# class valves are Factory Mutual approved except those supplied with Buna-N® resilient seats.



### Approvals & Certifications

- 125/150 Class Valves 4 - 10-inches - FM Approved
- 125/150 & 250/300 Class Valves 1 - 10-inches meet Federal Mandate for Lead Content Limits

### Pressure Ratings

- 125/150 (Rated to 250 psi)
- 250/300 (Rated to 640 psi)

Head Loss Characteristics for 580 Series Wafer Style Silent Check Valves

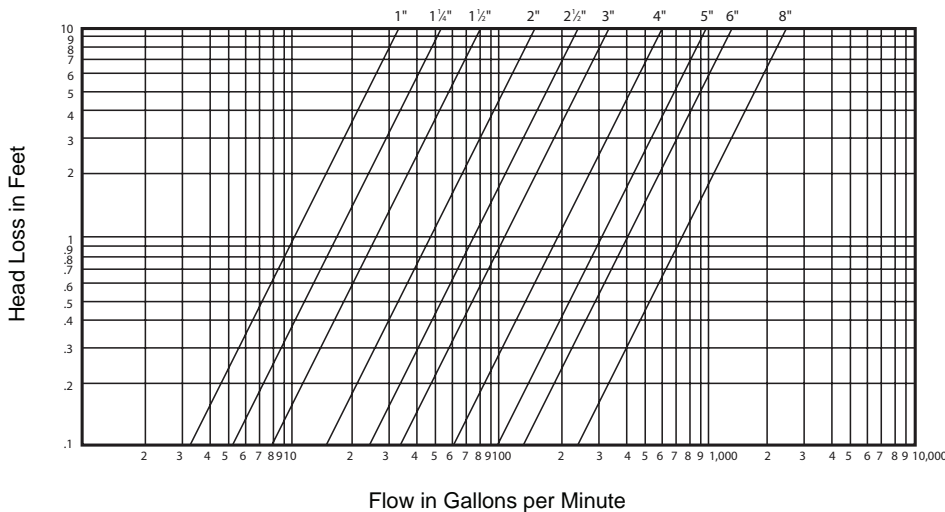

### Materials

#### Valve Body:

Ductile Iron - ASTM 536 65-45-12

#### Disc & Seat:

304 Stainless Steel -  
SS ASTM A276 T304



#### Spring:

316 Stainless Steel; Stone  
Tumbled and Stress Relieved - SS  
ASTM A276 T16

#### Note:

Standard offering is two-part epoxy coating interior and exterior

# 125/150 & 250/300 Class Silent Wafer Check Valve: 1 thru 6-inches

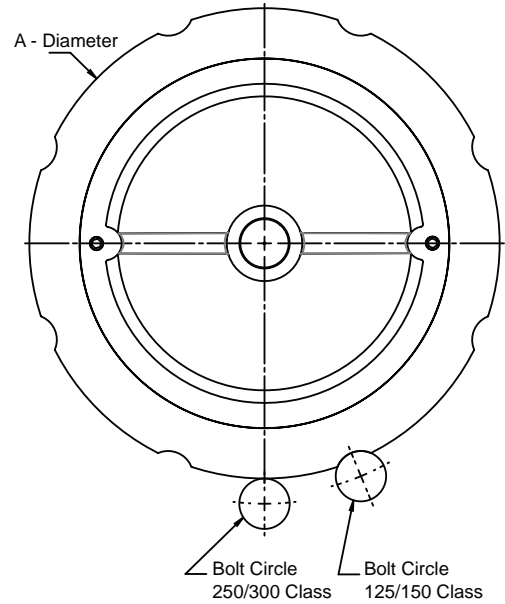
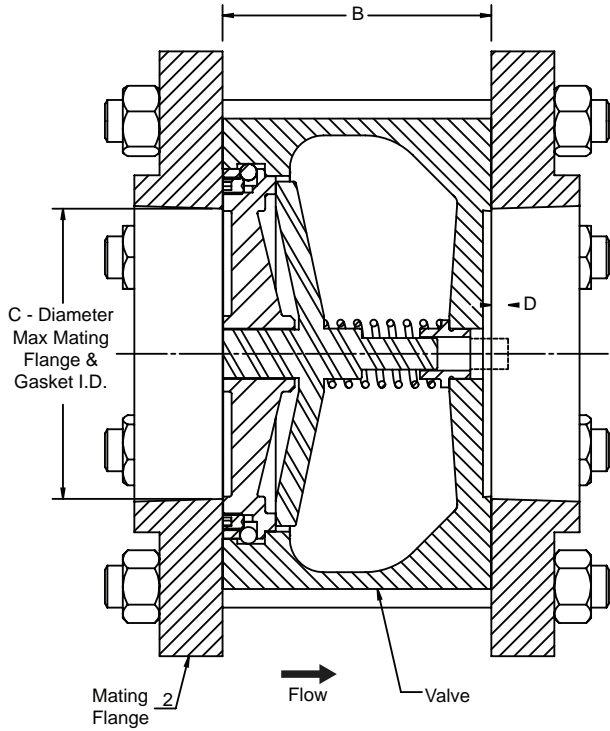

Valve Size (inches)	A	B	C	D
1	2.75	2.06	1.25	0.06
1.25	3.13	2.06	1.50	0
1.50	3.63	2.38	1.81	0.09
2	4.25	2.63	2.38	0
2.50	5.00	2.88	2.88	0
3	5.75	3.13	3.38	0.06
4	7.00	4.00	4.75	0.06
5	8.38	4.63	5.50	0.50
6	9.75	5.50	6.50	0.88

Valve Size (mm)	A	B	C	D
25	69.9	52.4	31.8	1.6
32	79.4	52.4	38.1	0
40	92.1	60.3	46.0	2.4
50	108.0	66.7	60.3	0
65	127.0	73.0	73.0	0
80	146.1	79.4	85.7	1.6
100	177.8	101.6	120.7	1.6
125	212.7	117.5	139.7	12.7
150	247.7	139.7	165.1	22.2

**Note:** Dimensions are the same for both 125/150 and 250/300 Class Valves.

## Specifications

The silent wafer check valve shall consist of a heavy ductile iron body, stainless steel seat, disc, and steel spring. The valve disc shall be center guided at both ends with an integral shaft and shall be spring loaded for silent operation. The spring shall be helical or conical and stone tumbled to achieve a micro-finish to resist mineral deposits. For ease of maintenance, the seat and disc shall be replaceable in the field.

Check valve shall be capable of silent operation when installed in vertical or horizontal positions with either flow up or flow down. The flow area through the body shall be equal to or greater than the cross-section area of the equivalent pipe size.

## 125/150 Class Silent Wafer Check Valve: 8 & 10-inches

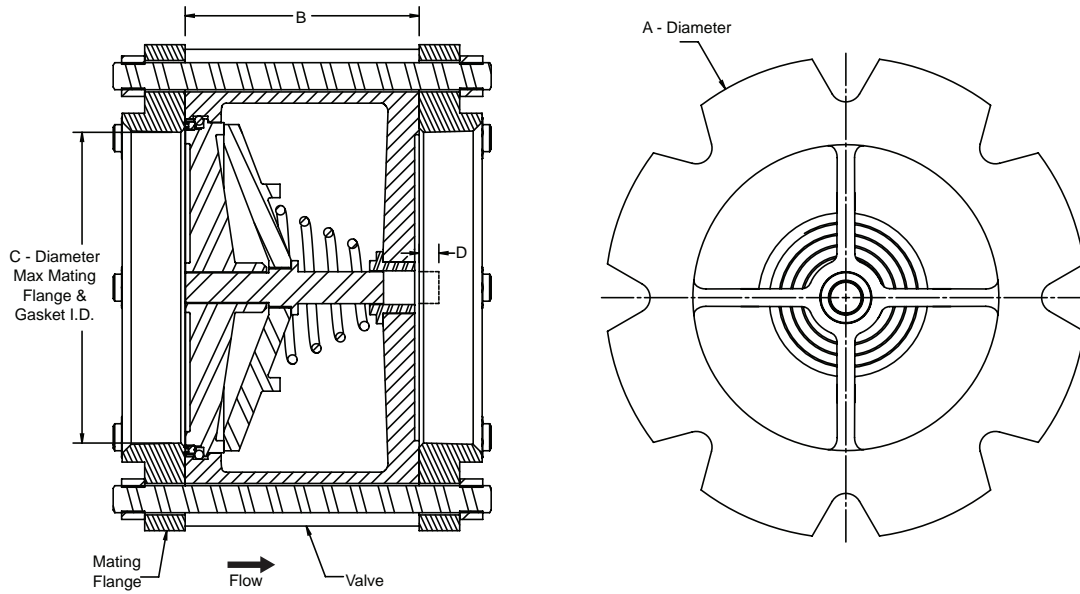

## 250/300 Class Silent Wafer Check Valve: 8 & 10-inches

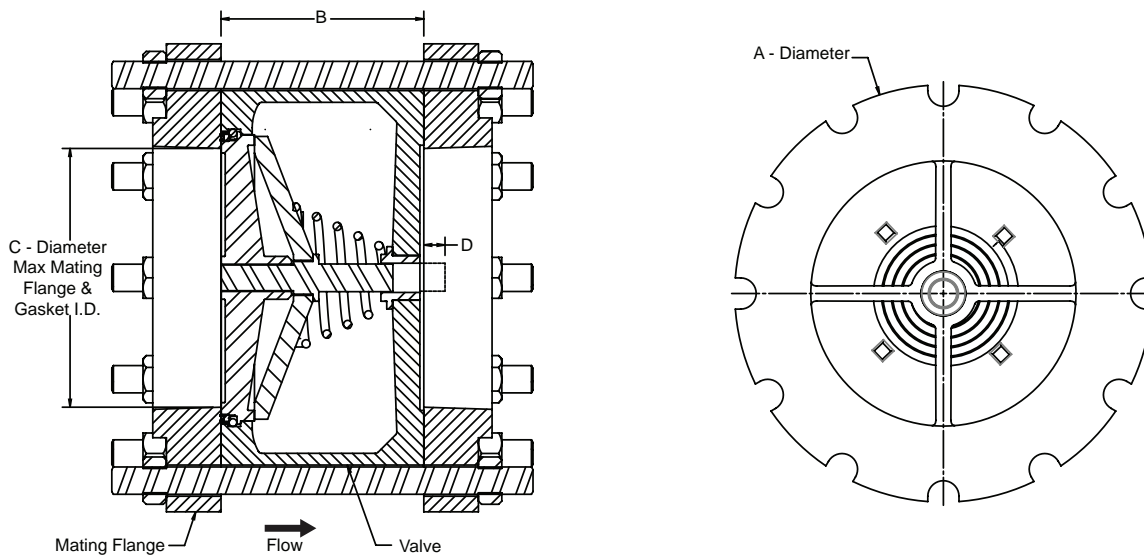

Valve Size (inches)	A	B	C	D
8	13.38	6.50	8.50	1.88
10	16.00	8.25	10.50	1.19

Valve Size (mm)	A	B	C	D
200	339.7	165.1	215.9	47.6
250	406.4	209.6	266.7	30.2

**Note:** Dimensions are the same for both 125/150 and 250/300 Class Valves.

# 580 Series Silent Wafer Check Valve Technical Data

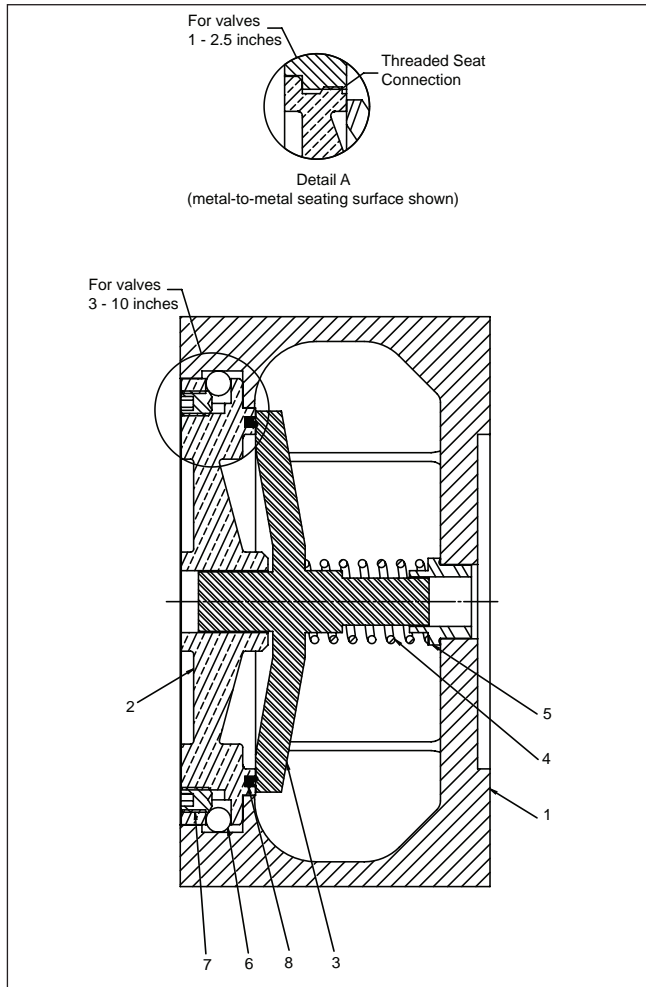

Item	Description	Qty	Material Description
1	Body	1	Ductile Iron 536 65-45-12
2	Seat	1	SS ASTM A276 T304
3	Plug	1	SS ASTM A276 T304
4	Spring	1	SS ASTM A276 T316
5	Bushing	1	SS ASTM A276 T304
6	Seat Retaining Ball (3"-10")	2	SS ASTM A276 T304
7	Seat Retaining Screw (3"-10")	2	SS ASTM A276 T304
8	Optional Resilient Seat	1	Buna-N®

## Typical Applications

Cla-Val 580 Series Silent Wafer Check Valves are used anywhere a quick, quiet closure is desired and in the majority of pump applications, including the following;

- Fire Pump Applications
- Vertical Turbine Pumps
- Booster Pump Stations in High Rise Buildings
- House Pump Applications

Maximum Non-Shock Service Pressure, PSI/kPa																		
Temp °F °C	Cast Iron ASTM A126 GR.B						Ductile Iron ASTM A536		Bronze ASTM B62		Carbon Steel ASTM A216 GR WCB				Stainless Steel ASTM A351 CF 8M			
	Class 125#			Class 250#			Pressure Class		Pressure Class		Pressure Class				Pressure Class			
	1-12" 25-300	14-24" 350-600	30" ≥ 750 ≥	1-12" 25-300	14-24" 350-600	30" ≥ 750 ≥	150	300	150	300	150	300	400	600	150	300	400	600
0-150 -18-66	—	—	—	—	—	—	—	225 1551	500 3447	—	—	—	—	—	—	—	—	
-20-100 -29-38	—	—	—	—	—	—	250 1724	640 4413	—	—	285 1965	740 5102	990 6826	1480 10204	275 1896	720 4964	960 6619	1440 9928
-20-150 -29-66	200 1379	150 1034	150 1034	500 3447	300 2068	300 2068	242 1669	620 4275	—	—	272 1875	707 4875	945 6516	1415 9756	257 1772	670 4619	892 6150	1340 9239
200 93	190 1310	135 931	115 793	460 3172	280 1931	250 1724	235 1620	600 4137	210 1448	465 3206	260 1793	675 4654	900 6205	1350 9308	240 1655	620 4275	825 5688	1240 8549
250 121	175 1207	125 862	85 586	415 2861	260 1793	200 1379	235 1620	582 4013	195 1344	425 2930	245 1689	665 4585	887 6116	1332 9184	227 1565	590 4068	785 5412	1180 8136
300 149	165 1138	110 758	50 345	375 2586	240 1655	150 1034	215 1482	565 3896	180 1241	390 2689	230 1586	655 4516	875 6033	1315 9067	215 1482	560 3861	745 5137	1120 7722
Seal Test PSI kPa	200 1379	150 1034	150 1034	500 3447	300 2068	300 2068	275 1896	720 4964	300 2068	1000 6895	315 2172	815 5619	1090 7515	1630 11238	305 2103	795 5481	1060 7308	1585 10928
Shell Test PSI kPa	300 2068	230 1586	230 1586	750 5171	450 3103	450 3103	400 2758	975 6722	450 3103	1500 10342	450 3103	1125 7757	1500 10342	2225 15341	425 2930	1100 7584	1450 9997	2175 14996

F<sup>in</sup> PSI Inch  
C<sup>o</sup> kPa Millimeter



# Series 581

## Silent Globe Check Valve



### Product Advantages

- Operates Horizontally or Vertically
- Watertight Metal-to-Metal Seating
- Field Replaceable Parts
- Factory Mutual Approved – 4 through 12-inches
- Optional Resilient Seat

The Cla-Val Series 581 Silent Globe Check Valve has a spring-loaded poppet that allows the valve to close at 1/4 psi before flow reversal occurs, resulting in a silent, non-slam closure.

Constructed of a ductile iron body with stainless steel trim, the Cla-Val Silent Globe Check Valve offers watertight shutoff with metal-to-metal seating. Buna-N<sup>®</sup> resilient seats are available as an option for special applications,

### Specifications

The silent globe check valve shall consist of an epoxy-coated ductile iron body, stainless steel seat, disc and spring. The valve disc shall be center guided at both ends with an integral shaft and shall be spring loaded for silent operation. The spring shall be helical or conical and stone tumbled to achieve a micro-finish to resist mineral deposits. For ease of maintenance, the seat and disc shall be replaceable in the field.

Check valve shall be capable of silent operation when installed in vertical or horizontal positions with either flow up or flow down. The flow area through the body shall be equal to or greater than the cross-section area of the equivalent pipe size. Sizes 2 1/2" to 10" shall allow bolting a wafer style butterfly valve directly to the outlet flange without a spool piece.

### Approvals & Certifications

- 125/150 and 250/300 Class Valves 4 through 12-inches - FM Approved
- 125/250 & 250/300 Class valves 3 through 42-inches meet Federal Mandate for Lead Content Limits



4 through 12-inches

### Pressure Ratings

- 125/150 (Rated to 250 psi)
- 250/300 (Rated to 640 psi)

Series 581 Pressure Loss Curve  
(Typical)

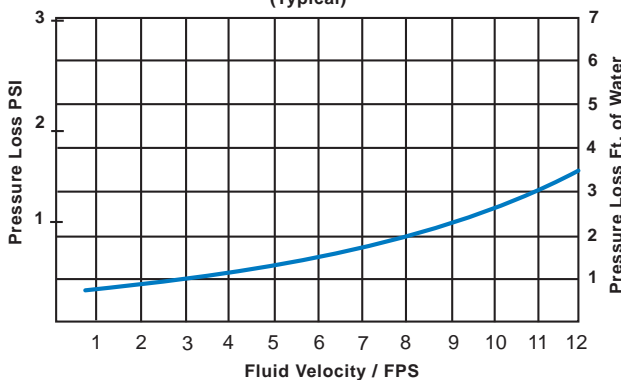

### Materials

#### Valve Body:

Ductile Iron - ASTM 536 65-45-12

#### Disc & Seat:

304 Stainless Steel - SS ASTM A276 T304

#### Spring:

316 Stainless Steel; Stone Tumbled and Stress Relieved - SS ASTM A276 T16



#### Note:

Standard offering is two-part epoxy coating interior and exterior

# 581 Series - 125/150 Class Silent Globe Check Valve

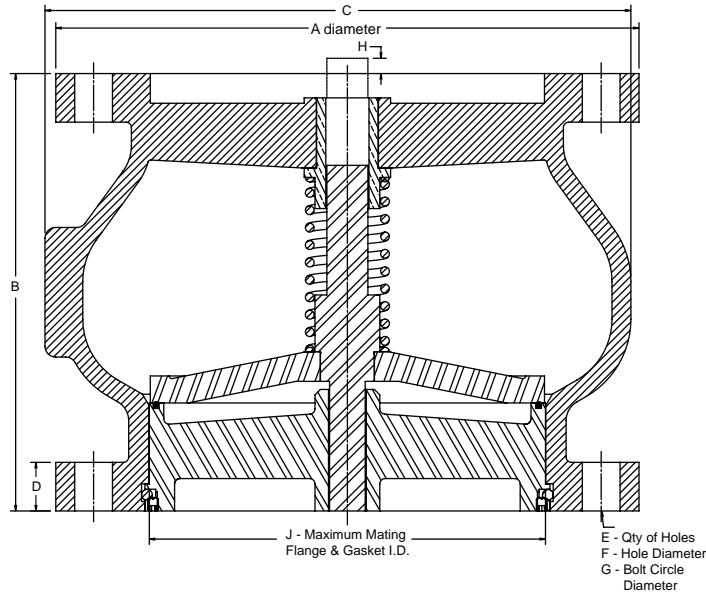

Valve Size (inches)	A	B	C	D	E	F	G	H	J
3	7.50	6.00	6.06	0.94	4	0.75	6.00	0	3.38
4	9.00	7.25	7.63	0.94	8	0.75	7.50	0	4.75
5	10.00	8.50	9.38	0.94	8	0.88	8.50	0	5.50
6	11.00	9.00	10.88	1.00	8	0.88	9.50	0	6.50
8	13.50	10.13	13.69	1.13	8	0.88	11.75	0	8.50
10	16.00	12.00	17.50	1.19	12	1.00	14.25	0.16	10.75
12	19.00	14.38	20.56	1.25	12	1.00	17.00	0.31	12.88
14	21.00	15.7	22.56	1.38	12	1.13	18.75	0	14.75
16	23.50	17.63	25.50	1.44	16	1.13	21.25	0.69	16.50
18	25.00	18.75	27.25	1.56	16	1.25	22.75	1.38	18.75
20	27.50	20.63	31.25	1.69	20	1.25	25.00	1.13	20.63
24	32.00	24.00	37.19	1.88	20	1.38	29.50	2.25	24.75
30	38.75	29.5	45.13	2.13	28	1.38	36.00	3.56	29.50
36	46.00	45.00	53.38	2.38	32	1.63	42.75	0	36.00
42	53.00	50.00	60.00	2.63	36	1.63	49.50	0	42.00

Valve Size (mm)	A	B	C	D	E	F	G	H	J
80	190.5	152.4	154.0	23.8	4	19.1	152.4	0	85.7
100	228.6	184.2	193.7	23.8	8	19.1	190.5	0	120.7
125	254.0	215.9	238.1	23.8	8	22.2	215.9	0	139.7
150	279.4	228.6	276.2	25.4	8	22.2	241.3	0	165.1
200	342.9	257.2	347.7	28.6	8	22.2	298.5	0	215.9
250	406.4	304.8	444.5	30.2	12	25.4	362.0	4.0	273.1
300	482.6	365.1	522.3	31.8	12	25.4	431.8	7.9	327.0
350	533.4	400.1	573.1	34.9	12	28.6	476.3	0	374.7
400	596.9	447.7	647.7	36.5	16	28.6	539.8	17.5	419.1
450	635.0	476.3	692.2	39.7	16	31.8	577.9	34.9	476.3
500	698.5	523.9	793.8	42.9	20	31.8	635.0	28.6	523.9
600	812.8	609.6	944.6	47.6	20	34.9	749.3	57.2	628.7
750	984.3	743.0	1146.2	54.0	28	34.9	914.9	90.5	749.3
900	1168.4	1143.0	1355.7	60.3	32	41.3	1085.9	0	914.4
1000	1346.2	1270.	1524.0	66.7	36	41.3	1257.3	0	1066.8

# 581 Series - 250/300 Class Silent Globe Check Valve

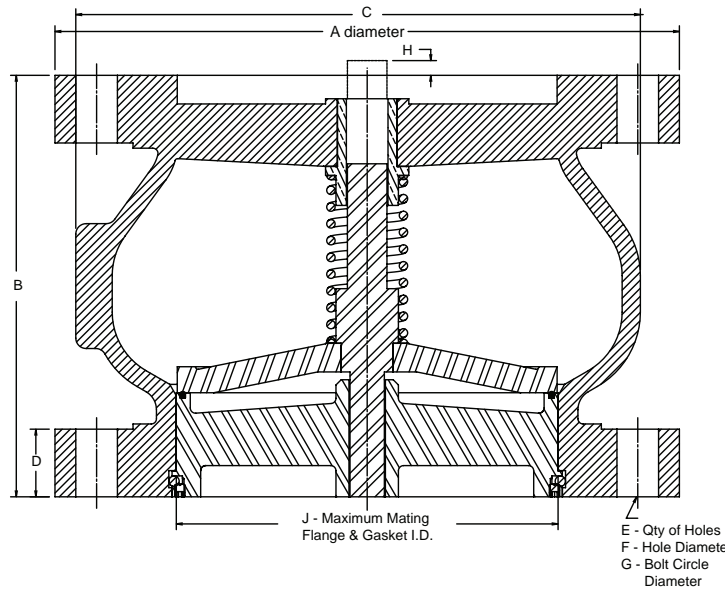

Valve Size (inches)	A	B	C	D	E	F	G	H	J
3	8.25	6.00	6.06	1.13	8	0.88	6.63	0	3.38
4	10.00	7.25	7.63	1.25	8	0.88	8.25	0	4.75
5	11.00	8.50	9.38	1.38	8	0.88	9.25	0	5.50
6	12.50	9.00	10.88	1.44	12	1.00	10.56	0	6.50
8	15.00	10.13	13.69	1.63	12	1.00	13.00	0	8.50
10	17.50	12.00	17.50	1.88	16	1.13	15.25	0.16	10.75
12	20.50	14.38	20.56	2.00	16	1.25	17.75	0.31	12.88
14	23.00	15.75	22.56	2.13	20	1.25	20.25	0	14.75
16	25.50	17.63	25.50	2.25	20	1.38	22.50	0.69	16.50
18	28.00	18.75	27.25	2.38	24	1.38	24.75	1.38	18.75
20	30.50	20.63	31.25	2.50	24	1.38	27.00	1.13	20.63
24	36.00	24.00	37.19	2.75	24	1.63	32.00	2.25	24.75
30	43.00	29.25	45.13	3.00	28	1.88	39.25	3.56	29.50
36	50.00	45.00	53.38	3.38	32	2.25	46.00	0	36.00
42	57.00	50.00	60.00	3.69	36	2.25	52.75	0	42.00

Valve Size (mm)	A	B	C	D	E	F	G	H	J
80	209.6	152.4	154.0	28.6	8	0.88	6.63	0	3.38
100	254.0	184.2	193.7	31.8	8	22.2	200.0	0	120.7
125	254.0	215.9	238.1	34.9	8	22.2	235.0	0	139.7
150	317.5	228.6	276.2	36.5	12	22.2	268.1	0	165.1
200	381.0	257.2	347.7	41.3	12	25.4	330.2	0	215.9
250	444.5	304.8	444.5	47.6	16	28.6	387.4	4.0	273.1
300	520.7	365.1	522.3	50.8	16	31.8	450.9	7.9	327.0
350	584.2	400.1	573.1	54.0	20	31.8	514.4	0	374.7
400	647.7	447.7	647.7	57.2	20	34.9	571.5	17.5	419.1
450	711.2	476.3	692.2	60.3	24	34.9	628.7	34.9	476.3
500	774.7	523.9	793.8	63.5	24	34.9	685.8	28.6	523.9
600	914.4	609.6	944.6	69.9	24	41.3	812.8	57.2	628.7
750	1092.2	743.0	1146.2	76.2	28	47.6	997.0	90.5	749.3
900	1270.0	1143.0	1355.7	85.7	32	57.2	1168.4	0	914.4
1000	1447.8	1270.0	1524.0	93.7	36	57.2	1339.9	0	1066.8

# 581 Series Silent Globe Check Valve Technical Data

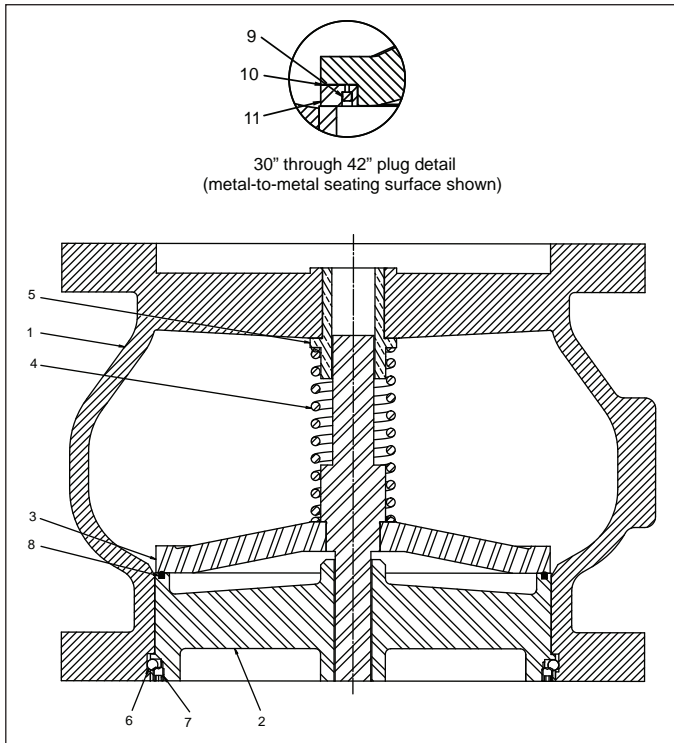

Item	Description	Qty	Material Description
1	Body	1	Ductile Iron 536 65-45-12
2	Seat	1	SS ASTM A276 T304
3	Plug	1	SS ASTM A276 T304
4	Spring	1	SS ASTM A276 T316
5	Bushing	1	SS ASTM A276 T304
6	Seat Retaining Ball	2	SS ASTM A276 T304
7	Seat Retaining Screw	2	SS ASTM A276 T304
8	Optional Resilient Seat	1	Buna-N <sup>®</sup>
9	Plug Ring (30"- 42")	1	Buna-N <sup>®</sup>
10	Gasket (30"- 42")	1	Buna-N <sup>®</sup>
11	Plug Ring Screw (30"- 42")	1	SS ASTM A276 T304

## Typical Applications

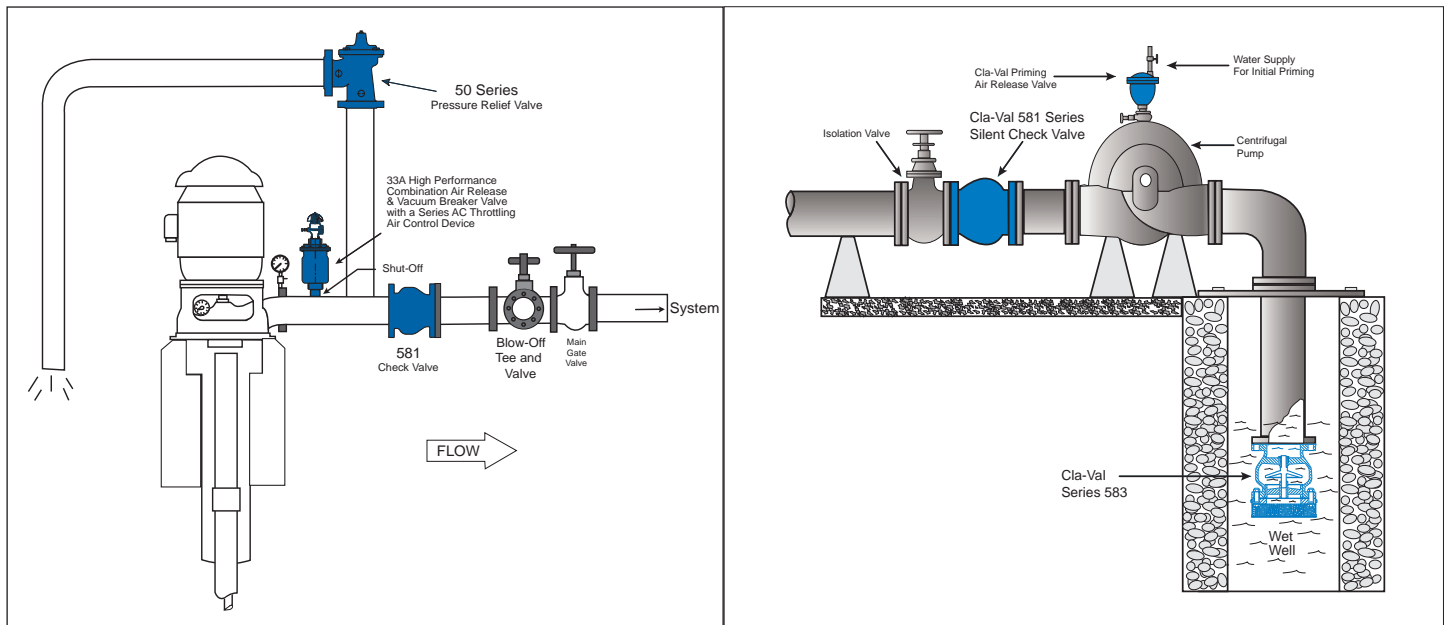

Cla-Val 581 Series Silent Globe Check Valves are used anywhere a quick, quiet closure is desired and in the majority of pump applications, including the following;

- Fire Pump Applications
- Vertical Turbine Pumps
- Booster Pump Stations in High Rise Buildings
- House Pump Applications



# Series 582SWS

For Seawater Service

## Two-Door Wafer Check Valve



582SWS Sizes 6" thru 24"

### SPECIFICATIONS

The two-door wafer check valve shall be compact wafer design, to fit between ANSI flanges. The check valve doors shall be spring-loaded closed, by means of one or more heavy-duty stainless steel torsion springs. Flow shall cause the doors to open and upon pump shut down, the torsion spring will shut the doors, before reverse flow starts, for non-slam closure.

Seating shall be resilient and watertight. The sealing element shall be Nitrile rubber molded to the body. Valves 6" and larger shall be fitted with a tapped hole to mount an eye bolt for lifting. The valve shall be a Cla-Val Series 582SWS Two-Door Wafer Check Valve.

- Low Head Loss
- Resilient Seat
- Non-Slam Closure
- Stabilizer Spheres Prevent Vibration Wear
- Factory Mutual Approved – Various Sizes
- Corrosion Resistant Material of Construction for Seawater Applications

The Cla-Val Series 582SWS Two-Door Wafer Check Valve has torsion springs that force the two doors to shut before flow reversal, reducing the water hammer potential that normally occurs with single-door swing check valves. To help reduce water hammer, the two-door design also reduces the travel distance from open to shutoff for a quicker response. Extremely short in lay length, the valve is both a compact and an economical solution. Two-Door Wafer Check Valves are available in sizes 6" to 24" with either a 125 lb. or 250 lb. pressure class rating.

Although lighter in weight than globe style swing check valves, Cla-Val Two-Door Wafer Check Valves are designed for heavy-duty applications. For ease of installation, valves 6" and larger are supplied with a tapped hole for installing a lifting eye bolt. All materials conform to ASTM specifications, ensuring long lasting reliable performance. As a confirmation of Cla-Val's commitment to quality, 6" to 24" 125 lb. class Series 582SWS valves are Factory Mutual approved.

### Typical Application

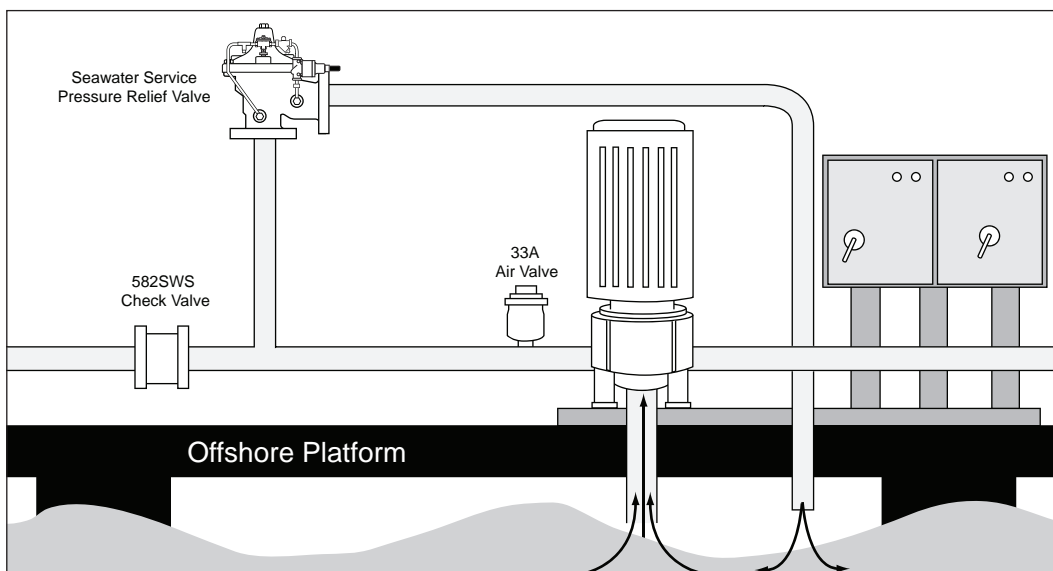

# Series 582SWS Two-Door Wafer Check Valve

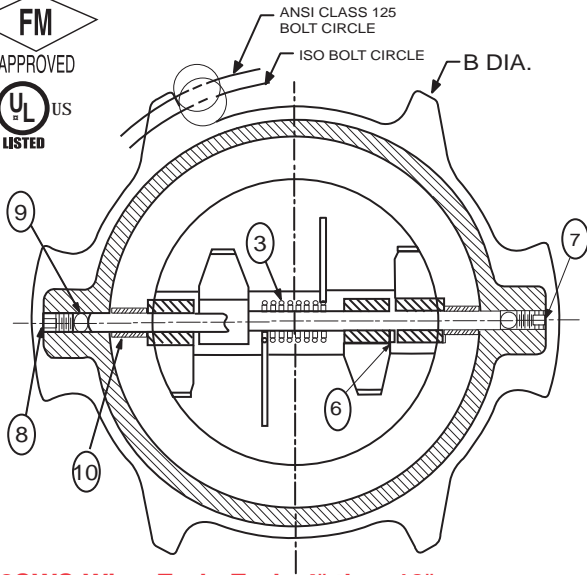

**582SWS Wing Ends Ends 4" thru 12"**

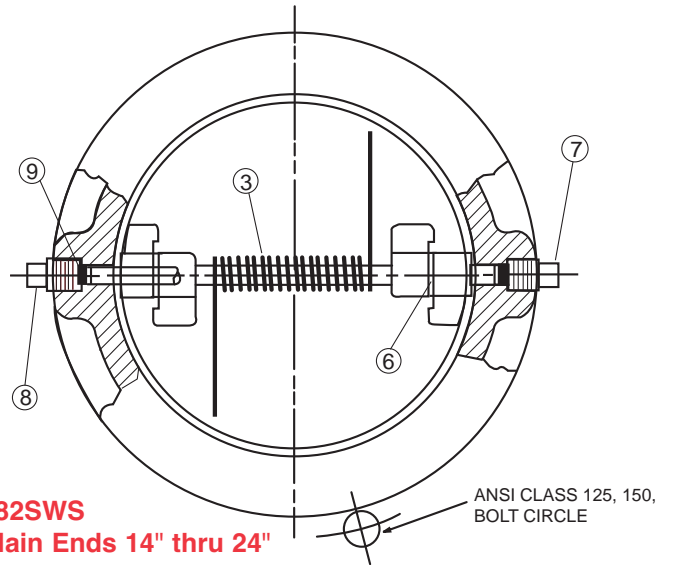

**582SWS Plain Ends 14" thru 24"**

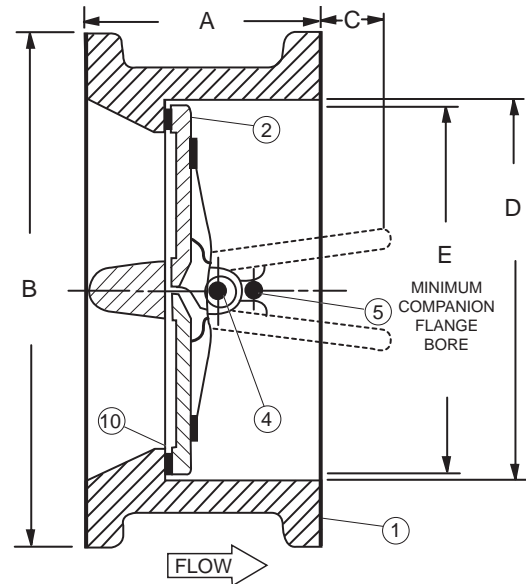
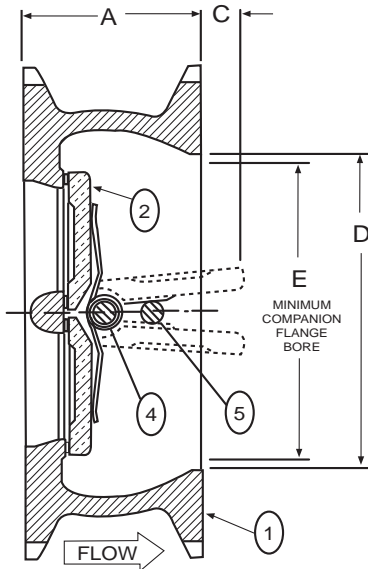

Part No.	Name	Material
1	Body	Aluminum Bronze ASTM B148, Alloy 95200 with Buna-N® resilient Seat Molded Body
2	Door	Aluminum Bronze ASTM B148, Alloy 95200
3	Torsion Springs	Inconel X750, ASTM B637 Alloy N04400
4	Door Hinge Pin	Monel ASTM B164, Alloy N04400
5	Door Stop Pin	Monel ASTM B164, Alloy N04400

Part No	Name	Material
6	Door Thrust Bearing	Monel ASTM B164, Alloy N04400
7	Hinge Pin Retainer	Monel 400
8	Stop Pin Retainer	Monel 400
9	Stabilization Sphere	Buna-N®
10	Spacer (2" - 12" Sizes)	Monel ASTM B164, Alloy N04400

## Dimensions (In Inches)

Size	Model	A	B	C	D	E
<b>Wing Ends Two-Door Wafer Check Valve - ANSI Class 150</b>						
4*	582SWS.4	2 5/8	6 7/8	1	4 5/8	3 7/8
6*	582SWS.6	3 3/4	8 5/8	1 1/4	6 1/4	4 1/4
8*	582SWS.8	5	12 1/4	1 5/8	8	5 1/2
10*	582SWS.10	5 1/2	14 3/4	2 1/2	10 1/4	8 1/2
12*	582SWS.12	7 1/8	17 3/8	1 15/16	12	9 1/4
<b>Plain Ends Two-Door Wafer Check Valve for Seawater Service</b>						
14	582SWS.14	7 1/4	17 3/4	3 1/8	14 3/8	12 1/2
16	582SWS.16	7 1/2	20 1/4	4 1/2	16 3/8	15
18	582SWS.18	8	21 5/8	5 3/8	18 3/8	17
20	582SWS.20	8 3/8	23 7/8	6 3/8	20 1/4	19
24	582SWS.24	8 3/4	28 1/4	8 1/2	24 1/4	23

\* FM Approved



# Series 582W Series 582G

## Two-Door Check Valve



2 1/2" - 16"  
65 - 400mm

APPROVED



2 1/2" - 12"  
65 - 300mm

### SPECIFICATIONS

The two-door wafer check valve shall be compact wafer design, to fit between flanges or grooved ends. The check valve doors shall be spring-loaded closed, by means of one or more stainless steel torsion springs. Flow shall cause the doors to open and upon pump shut down, the torsion spring shall shut the doors, before reverse flow, for anti-slam closure.

Seating shall be resilient Buna-N®, watertight and molded to the body. Valves 6" and larger shall be supplied with an eye bolt for lifting. The valve shall be a Cla-Val Series 582W 2"-12" having alignment wings for mounting between ANSI 125, ISO PN10 or PN16 flanges or Series 582 (14"-60") for mounting between ANSI 125 or 150 flanges or Series 582G (2"-12") with grooved ends for mounting between groove end piping.

All materials of construction shall conform to ASTM specifications as follows:

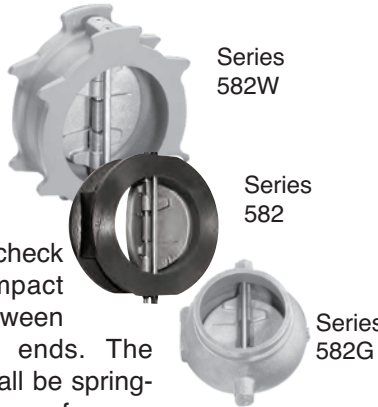

- New - Lower Head Loss Design
- New - Alignment Wings for ANSI 125, ISO PN10 & PN16 Mounting
- High Speed Anti-Slam Closure
- Stabilizer Spheres Prevent Vibration Wear
- Factory Mutual Approved / UL Listed
- Plain Ends or Grooved Ends

All Cla-Val Series 582 Two-Door Check Valves utilize a torsion springs that very quickly shut the valve, before flow reversal. To minimize Slam / Water Hammer typically experienced with conventional swing check valves. Basically Two Door design valves, halves the travel distance from open valve to shut-off vs swing check valves and is the reason for the Anti-slam / Minimum Water Hammer feature. With extremely short laying lengths series 582W and Series 582 are space savings & an economical solution. The Series 582G with grooved ends provides for ease of installation and removal from pipelines.

Although lighter in weight than conventional swing check valves, Cla-Val Two-Door Wafer Check Valves are designed for heavy-duty applications. For ease of installation, valves 6" and larger are supplied with lifting eye bolts. All materials conform to ASTM specifications, ensuring long lasting reliable performance.

#### Valve Body:

Series 582W & 582G 2" - 12"  
Ductile Iron ASTM A536  
Series 582 14" - 16"  
Cast Iron ASTM A126, Class B

#### Doors:

2" - 12" Bronze ASTM B584  
14" - 60" Aluminum Bronze ASTM B148

#### Sealing Element:

Buna-N® 316

#### Torsion Spring:

Stainless Steel

#### Hinge:

Stainless Steel

#### Stop:

Stainless Steel

#### Sizes:

2" to 60"

### Series 582 Pressure Loss Curve

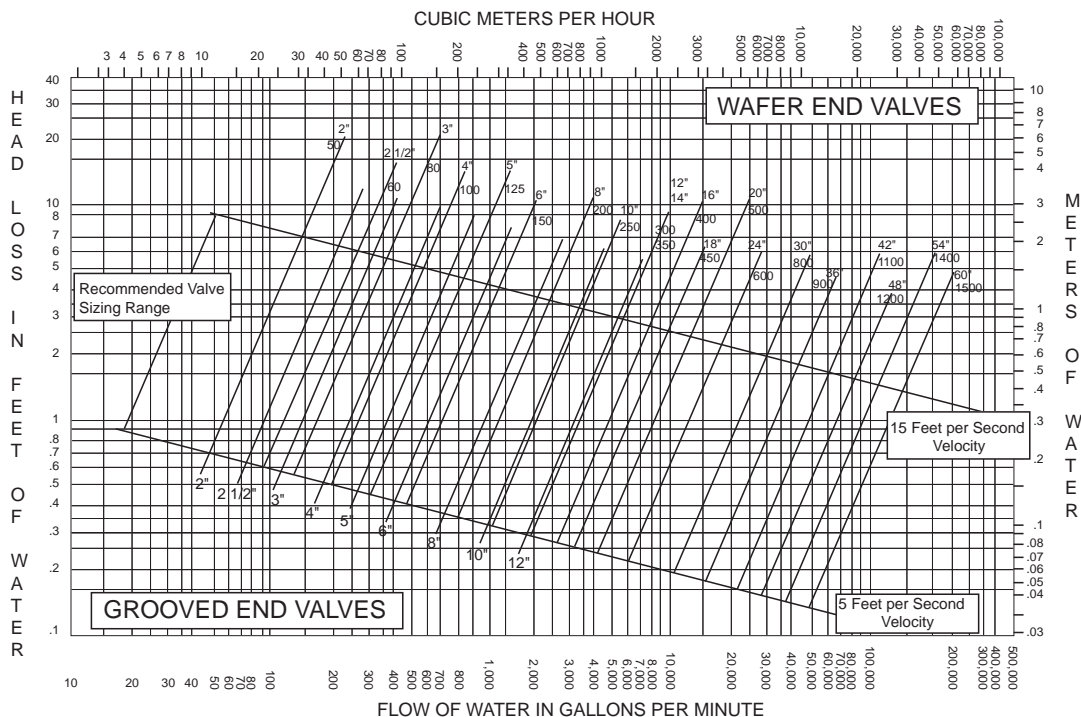

# Series 582 Two-Door Wafer Check Valve

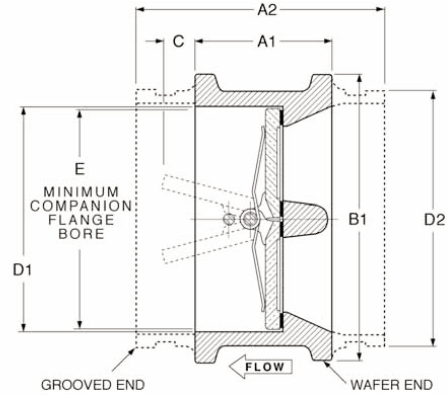
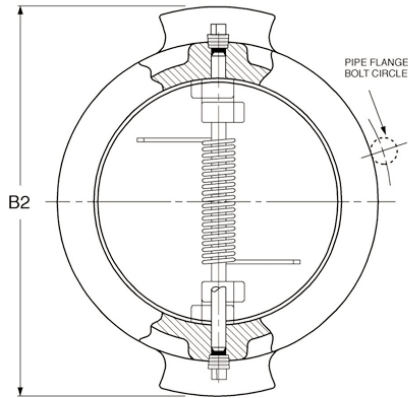
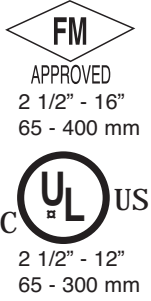

## Dimensions (In Inches)

Cla-Val Series 582 Two-Door Wafer Check Valve ANSI CLASS 125									Wafer	Grooved
Size	A	A2	B1	B2	C	D1	D2	E	Wt Lbs.	Wt Lbs.
2	2 1/8	4 21/32	4 1/8	5 1/8	3/16	2 9/16	2 3/8	1 15/16	4	4
2 1/2	2 3/8	4 29/32	4 7/8	6	5/16	3 1/16	2 7/8	2 5/16	5	5
3	2 5/8	5 5/16	5 3/8	5 5/8	1/2	3 11/16	3 1/2	2 7/8	7	8
4	2 5/8	5 3/8	6 7/8	7 3/4	1	4 5/8	4 1/2	3 7/8	9	9
5	3 1/4	5 23/32	7 3/4	7 9/16	1 1/8	5 11/16	5 9/16	4 13/16	13	13
6	3 3/4	6	8 3/4	8 5/8	1 1/4	6 3/4	6 5/8	5 3/4	19	18
8	5	6 23/32	11	12 1/4	1 5/16	8 3/4	8 5/8	7 5/8	38	30
10	5 1/2	7 25/32	13 3/8	13 3/4	2 1/2	10 7/8	10 3/4	9 9/16	65	56
12	7 1/8	8 3/16	16 1/8	17 3/8	2 3/8	12 7/8	12 3/4	11 3/8	94	81
14	7 1/4	N/A	17 3/4	N/A	3 1/4	14 3/4	N/A	12 1/2	187	N/A
16	7 1/2	N/A	20 1/4	N/A	4 1/2	16 3/8	N/A	15	270	N/A
18	8	N/A	21 5/8	N/A	5 3/8	18 3/8	N/A	17	330	N/A
20	8 3/8	N/A	23 3/8	N/A	6 3/8	20 1/4	N/A	19	424	N/A
24	8 3/4	N/A	28 1/4	N/A	8 1/2	24 1/4	N/A	23	589	N/A
30	12	N/A	34 3/4	N/A	9 1/2	30	N/A	28 1/2	1,112	N/A
36	14 1/2	N/A	41 1/4	N/A	12	36	N/A	34 1/2	1,864	N/A
42	17	N/A	48	N/A	13 3/4	42	N/A	40 1/2	2,889	N/A
48*	20 5/8	N/A	N/A	59 1/2	17	48	N/A	46 1/2	5,525	N/A
54*	21 1/4	N/A	N/A	66 1/4	20	54	N/A	52 1/2	7,000	N/A
60*	26	N/A	N/A	73	19	60	N/A	58 1/2	10,100	N/A

## INSTALLATION

Install the Cla-Val Series 582 Two-Door Wafer Check Valve between standard flanges in the horizontal or in the vertical, flow up, position.

## Dimensions (mm)

\*Threaded Flange Standard

Cla-Val Series 582 Two-Door Wafer Check Valve ANSI CLASS 125									Wafer	Grooved
Size	A	A2	B1	B2	C	D1	D2	E	Wt Lbs.	Wt Lbs.
2	54	118.3	104.8	130.2	4.8	65.1	60.9	49.2	1.8	1.8
2 1/2	60.3	124.6	123.8	152.4	7.9	77.8	73	58.7	2.3	2.3
3	66.7	134.9	136.5	136.5	12.7	93.7	88.9	73	3.2	3.6
4	66.7	136.5	174.6	196.8	25.4	117.5	114.3	98.4	4.1	4.1
5	82.6	145.2	196.8	192.1	28.6	144.5	141.3	122.2	5.9	5.9
6	95.3	152.4	222.2	219.1	31.8	171.4	168.3	146	8.6	8.2
8	127	170.6	279.4	311.3	33.3	222.2	219.1	193.7	17.2	13.6
10	139.7	197.6	339.7	349.2	63.5	276.2	273	242.9	29.5	25.4
12	181	208	409.6	441.3	60.3	327	323.7	288.9	42.6	36.7
14	184.1	N/A	450.8	N/A	82.6	365.1	N/A	317.5	84.8	N/A
16	190.5	N/A	514.3	N/A	114.3	415.9	N/A	381	122	N/A
18	203.2	N/A	549.3	N/A	136.5	466.7	N/A	431.8	150	N/A
20	212.7	N/A	606.4	N/A	161.9	514.3	N/A	482.6	192	N/A
24	222.2	N/A	717.5	N/A	215.9	615.9	N/A	584.2	268	N/A
30	304.8	N/A	882.6	N/A	241.3	768	N/A	723.9	504	N/A
36	368.3	N/A	1048	N/A	304.8	914.4	N/A	876.3	846	N/A
42	431.8	N/A	1219	N/A	349.2	1067	N/A	1029	1310	N/A
48*	523.9	N/A	N/A	1511	431.8	1219	N/A	1181	2506	N/A
54*	539.8	N/A	N/A	1683	508	1372	N/A	1336	3175	N/A
60*	660.4	N/A	N/A	1854	482.6	1524	N/A	1486	4580	N/A

## NOTE:

For horizontal flow this valve MUST Be installed with disc hinge pin in the VERTICAL position for proper operation.



# Flange Dimensions and End Details

All flanged Cla-Val valves are furnished faced and drilled unless otherwise specified. The dimensions and drilling of end flanges conform to standards of the American National Standards Institute. The ANSI tables are given here for your convenience. When ANSI standards call for 1/16" raised face, this face is included in the dimensions for the thickness of flange. All dimensions are given in inches.

Ductile Iron Valves\* Class 150 and 300 (ANSI B16.42 — 1987)

Nominal Pipe Size	Diameter of Flange		Thickness of Flange		Diameter of Raised Face		Diameter of Bolt Circle		Number of Bolts		Diameter of Bolts		Diameter of Bolt Holes	
	150	300	150	300	150	300	150	300	150	300	150	300	150	300
Pressure Class	150	300	150	300	150	300	150	300	150	300	150	300	150	300
1.5	5.00	6.12	.56	.81	2.88	2.88	3.88	4.50	4	4	.50	.75	.62	.88
2	6.00	6.50	.62	.88	3.62	3.62	4.75	5.00	4	8	.63	.63	.75	.75
2.5	7.00	7.50	.69	1.00	4.12	4.12	5.50	5.88	4	8	.63	.75	.75	.88
3	7.50	8.25	.75	1.12	5.00	5.00	6.00	6.62	4	8	.63	.75	.75	.88
4	9.00	10.00	.94	1.25	6.19	6.19	7.50	7.88	8	8	.63	.75	.75	.88
6	11.00	12.50	1.00	1.44	8.50	8.50	9.50	10.62	8	12	.75	.75	.88	.88
8	13.50	15.00	1.12	1.62	10.62	10.62	11.75	13.00	8	12	.75	.88	.88	1.00
10	16.00	17.50	1.19	1.88	12.75	12.75	14.25	15.25	12	16	.88	1.00	1.00	1.12
12	19.00	20.50	1.25	2.00	15.00	15.00	17.00	17.75	12	16	.88	1.12	1.00	1.25
14	21.00	23.00	1.38	2.12	16.25	16.25	18.75	20.25	12	20	1.00	1.12	1.12	1.25
16	23.50	25.50	1.44	2.25	18.50	18.50	21.25	22.50	16	20	1.00	1.25	1.12	1.38
18	25.00	28.00	1.56	2.38	21.00	23.00	22.75	24.75	16	24	1.12	1.25	1.25	1.38
20	27.50	30.50	1.69	2.50	23.00	23.00	25.00	27.00	20	24	1.13	1.25	1.25	1.38
24	32.00	36.00	1.88	2.75	27.25	27.25	29.50	32.00	20	24	1.25	1.50	1.38	1.62
30	38.75	43.00	2.12	3.00	—	—	37.19	36.00	28	28	1.25	1.75	1.38	2.00
36	46.00	50.00	2.38	3.38	—	—	42.69	42.75	32	32	1.50	2.00	1.62	2.25

Cast Iron Valves\* Class 125 and 250 (ANSI B16.1 — 1989)

Nominal Pipe Size	Diameter of Flange		Thickness of Flange		Diameter of Raised Face		Diameter of Bolt Circle		Number of Bolts		Diameter of Bolts		Diameter of Bolt Holes	
	125	250	125	250	125	250	125	250	125	250	125	250	125	250
Pressure Class	125	250	125	250	125	250	125	250	125	250	125	250	125	250
1.5	5.00	6.12	.56	.81	—	2.88	3.88	4.50	4	4	.50	.75	.62	.88
2	6.00	6.50	.62	.88	—	3.62	4.75	5.00	4	8	.63	.63	.75	.75
2.5	7.00	7.50	.69	1.00	—	4.12	5.50	5.88	4	8	.63	.75	.75	.88
3	7.50	8.25	.75	1.12	—	5.00	6.00	6.62	4	8	.63	.75	.75	.88
4	9.00	10.00	.94	1.25	—	6.19	7.50	7.88	8	8	.63	.75	.75	.88
6	11.00	12.50	1.00	1.44	—	8.50	9.50	10.62	8	12	.75	.75	.88	.88
8	13.50	15.00	1.12	1.62	—	10.62	11.75	13.00	8	12	.75	.88	.88	1.00
10	16.00	17.50	1.19	1.88	—	12.75	14.25	15.25	12	16	.88	1.00	1.00	1.12
12	19.00	20.50	1.25	2.00	—	15.00	17.00	17.75	12	16	.88	1.12	1.00	1.25
14	21.00	23.00	1.38	2.12	—	16.25	18.75	20.25	12	20	1.00	1.12	1.12	1.25
16	23.50	25.50	1.44	2.25	—	18.50	21.25	22.50	16	20	1.00	1.25	1.12	1.38
18	25.00	28.00	1.56	2.38	21.00	23.00	22.75	24.75	16	24	1.12	1.25	1.25	1.38
20	27.50	30.50	1.69	2.50	—	23.00	25.00	27.00	20	24	1.13	1.25	1.25	1.38
24	32.00	36.00	1.88	2.75	—	27.25	29.50	32.00	20	24	1.25	1.50	1.38	1.62

Bronze Valves\* Class 150 and 300 (ANSI 16.24 — 1979)

Nominal Pipe Size	Diameter of Flange		Thickness of Flange		Diameter of Raised Face		Diameter of Bolt Circle		Number of Bolts		Diameter of Bolts		Diameter of Bolt Holes	
	150	300	150	300	150	300	150	300	150	300	150	300	150	300
Pressure Class	150	300	150	300	150	300	150	300	150	300	150	300	150	300
1.5	5.00	6.12	.44	.69	—	—	3.88	4.50	4	4	.50	.75	.62	.88
2	6.00	6.50	.50	.75	—	—	4.75	5.00	4	8	.63	.63	.75	.75
2.5	7.00	7.50	.56	.81	—	—	5.50	5.88	4	8	.63	.75	.75	.88
3	7.50	8.25	.62	.91	—	—	6.00	6.62	4	8	.63	.75	.75	.88
4	9.00	10.00	.69	1.06	—	—	7.50	7.88	8	8	.63	.75	.75	.88
6	11.00	12.50	.81	1.19	—	—	9.50	10.62	8	12	.75	.75	.88	.88
8	13.50	15.00	.94	1.38	—	—	11.75	13.00	8	12	.75	.88	.88	1.00
10	16.00	—	1.00	—	—	—	14.25	—	12	—	.88	—	1.00	—
12	19.00	—	1.06	—	—	—	17.00	—	12	—	.88	—	1.00	—

Cast Steel Valves\* Class 150 and 300 (ANSI 16.5 — 1988)

Nominal Pipe Size	Diameter of Flange		Thickness of Flange		Diameter of Raised Face		Diameter of Bolt Circle		Number of Bolts		Diameter of Bolts		Diameter of Bolt Holes	
	150	300	150	300	150	300	150	300	150	300	150	300	150	300
Pressure Class	150	300	150	300	150	300	150	300	150	300	150	300	150	300
1.5	5.00	6.12	.56	.81	2.88	2.88	3.88	4.50	4	4	.50	.75	.62	.88
2	6.00	6.50	.62	.88	3.63	3.63	4.75	5.00	4	8	.63	.63	.75	.75
2.5	7.00	7.50	.69	1.00	4.13	4.13	5.50	5.88	4	8	.63	.75	.75	.88
3	7.50	8.25	.75	1.12	5.00	5.00	6.00	6.62	4	8	.63	.75	.75	.88
4	9.00	10.00	.94	1.25	6.19	6.19	7.50	7.88	8	8	.63	.75	.75	.88
6	11.00	12.50	1.00	1.44	8.50	8.50	9.50	10.62	8	12	.75	.75	.88	.88
8	13.50	15.00	1.12	1.62	10.63	10.63	11.75	13.00	8	12	.75	.88	.88	1.00
10	16.00	17.50	1.19	1.88	12.75	12.75	14.25	15.25	12	16	.88	1.00	1.00	1.12
12	19.00	20.50	1.25	2.00	15.00	15.00	17.00	17.75	12	16	.88	1.12	1.00	1.25
14	21.00	23.00	1.38	2.12	16.25	16.25	18.75	20.25	12	20	1.00	1.12	1.12	1.25
16	23.50	25.50	1.44	2.25	18.50	18.50	21.25	22.50	16	20	1.00	1.25	1.12	1.38
18	25.00	28.00	1.56	2.38	21.00	23.00	22.75	24.75	16	24	1.12	1.25	1.25	1.38
20	27.50	30.50	1.69	2.50	23.00	23.00	25.00	27.00	20	24	1.13	1.25	1.25	1.38
24	32.00	36.00	1.88	2.75	27.25	27.25	29.50	32.00	20	24	1.25	1.50	1.38	1.62

# CLA-VAL WARRANTY

## 3 Year Warranty on Cla-Val Quality Products



### This is a Limited Warranty

Automatic valves and controls as manufactured by Cla-Val are warranted for three years from date of shipment against manufacturing defects in material and workmanship that develop in the service for which they are designed, provided the products are installed and used in accordance with all applicable instructions and limitations issued by Cal-Val. Electronic components manufactured by Cla-Val are warranted for one year from the date of shipment.

We will repair or replace defective material, free of charge which is returned to our factory, transportation charges prepaid, provided that after inspection the material is found to have been defective at time of shipment. The warranty is expressly conditioned on the purchaser's giving Cla-Val immediate written notice upon discovery of the defect.

Components used by Cla-Val, but manufactured by others, are warranted only to the extent of that manufacturer's guarantee.

This warranty shall not apply if the product has been altered or repaired by others, and Cal-Val shall make no allowance or credit for such repairs or alterations unless authorized in writing by Cla-Val.

### Disclaimer of Warranties & Limitation of Liability

The foregoing warranty is exclusive and in lieu of all other warranties and representations whether expressed, implied, oral or written, including but not limited to, any implied warranties or merchantability or fitness for a particular purpose. All such other warranties and representations are hereby cancelled.

Cla-Val shall not be liable for any incidental or consequential loss, damage or expense arising directly or indirectly from the use of the product. Cla-Val shall not be liable for any damages or charges for labor or expense in making repairs or adjustments to the product. Cla-Val shall not be liable for any damages or charges sustained in the adaptation or use of its engineering data and services.

No representative of Cla-Val may change any of the foregoing or assume any additional liability or responsibility in connection with the product.

The liability of Cla-Val is limited to material replacements F.O.B. Newport Beach, California.

**CLA-VAL**  
1701 Placentia Avenue  
Costa Mesa CA  
92627  
Phone: 949-722-4800  
Fax: 949-548-5441  
E-mail: info@cla-val.com

**CLA-VAL CANADA**  
4687 Christie Drive  
Beamsville, Ontario  
Canada L0R 1B4  
Phone: 905-563-4963  
Fax: 905-563-4040  
E-mail sales@cla-val.ca

**CLA-VAL EUROPE**  
Chemin des Mésanges 1  
CH-1032 Romanel/  
Lausanne, Switzerland  
Phone: 41-21-643-15-55  
Fax: 41-21-643-15-50  
E-mail: cla-val@cla-val.ch

**CLA-VAL UK**  
Dainton House, Goods Station Road  
GB - Tunbridge Wells  
Kent TN1 2 DH England  
Phone: 44-1892-514-400  
Fax: 44-1892-543-423  
E-mail: info@cla-val.co.uk

**CLA-VAL FRANCE**  
Porte du Grand Lyon 1  
ZAC du Champ du Pérrier  
FR - 01700 Neyron  
Phone: 33-4-72-25-92-93  
Fax: 33-4-72-25-04-17  
E-mail: cla-val@cla-val.fr



# When protecting life and property, depend on Cla-Val.



## Global Headquarters

1701 Placentia Avenue  
Costa Mesa, CA 92627

Phone: (949) 722-4800  
(800) 942-6326  
Fax: (949) 548-5441  
E-mail: [info@cla-val.com](mailto:info@cla-val.com)

## Cla-Val Canada

4687 Christie Drive  
Beamsville, Ontario  
Canada L0R 1B4

Phone: (905) 563-4963  
Fax: (905) 563-4040  
E-mail: [sales@cla-val.ca](mailto:sales@cla-val.ca)

## Cla-Val Europe

Chemin des Mesanges 1  
CH-1032 Romanel/Lausanne  
Switzerland

Phone: 41-21-643-15-55  
Fax: 41-21-643-15-50  
E-mail: [cla-val@cla-val.ch](mailto:cla-val@cla-val.ch)

## Cla-Val UK

Dainton House, Goods Station Road  
GB - Tunbridge Wells  
Kent TN1 2 DH  
England

Phone: 44-1892-514-400  
Fax: 44-1892-543-423  
E-mail: [info@cla-val.co.uk](mailto:info@cla-val.co.uk)

## Cla-Val France

Porte du Grand Lyon 1  
ZI de Champ du Périe  
France - 01700 Neyo

Phone: 33-4-72-25-92-93  
Fax: 33-4-72-25-04-17  
E-mail: [cla-val@cla-val.fr](mailto:cla-val@cla-val.fr)

## Cla-Val Pacific Region

45 Kennaway Road  
Woolston, Christchurch, 8023  
New Zealand

Phone: (64) 39644860  
E-mail: [info@cla-valpacific.com](mailto:info@cla-valpacific.com)  
[www.cla-valpacific.com](http://www.cla-valpacific.com)

## US Regional Offices

Main E-mail: [info@cla-val.com](mailto:info@cla-val.com)

### Central Region

8707 Forney Road  
Dallas, TX 75227

Phone: (214) 388-3493  
(800) 533-8181  
Fax: (214) 381-9579

### Eastern Region

6911 Richmond Highway, Suite 444  
Alexandria, VA 22306

Phone: (703) 721-1923  
(800) 451-3030  
Fax: (703) 721-1927

### Western Region

1701 Placentia Avenue  
Costa Mesa, CA 92627

Phone: (951) 687-9145  
(800) 247-9090  
Fax: (951) 687-9954

### Cla-Val Latin America

Av Patria 2085, Piso 1  
Col. Puerta de Hierro  
45116; Zapopan, Jalisco

Phone: + 52 (33) 80007565  
Email: [info@cla-val-latinamerica.com](mailto:info@cla-val-latinamerica.com)  
[www.cla-val-latinamerica.com](http://www.cla-val-latinamerica.com)

### Cla Val Fire Product Team

2734 Sunrise, Suite 408-B  
Pearland, TX 77584  
(281) 741-4198

[fireprotection@cla-val.com](mailto:fireprotection@cla-val.com)

[www.cla-val.com](http://www.cla-val.com) | (800) 942-6326

CV\_Fire\_Catalog (R-07/2018)