



— MODEL — **690-01**

Pressure Reducing Valve



- Sensitive and Accurate Pressure Control
- Easy Adjustment and Maintenance
- Optional Check Feature
- Fully Supported Frictionless Diaphragm
- Meets National Lead Reduction Mandate

The Cla-Val Model 690-01 Pressure Reducing Valve automatically reduces a higher inlet pressure to a steady lower downstream pressure, regardless of changing flow rate and/or varying inlet pressure. This valve is an accurate, pilot-operated regulator capable of holding downstream pressure to a pre-determined limit. When downstream pressure exceeds the pressure setting of the control pilot, the main valve and pilot valve close drip-tight.

If a check feature is added, and a pressure reversal occurs, the downstream pressure is admitted into the main valve cover chamber, closing the valve to prevent return flow.

For space savings, see Cla-Val Model 690-48 or 690-99 with integral Low Flow Bypass Pressure Regulator.

Schematic Diagram

Item	Description
1	100-20 Hytrol Main Valve
2	X58 Restriction Fitting
3	CRD Pressure Reducing Control

Optional Features

Item	Description
A	X46A Flow Clean Strainer
B	CK2 Isolation Valve
C	CV Flow Control (Closing)*
D	Check Valves with Isolation Valve
M	X144 e-FlowMeter
P	X141 Pressure Gauge
S	CV Flow Control (Opening)
V	X101 Valve Position Indicator
Y	X43 "Y" Strainer

*The closing speed control (optional) on this valve should always be open at least three (3) turns off its seat.

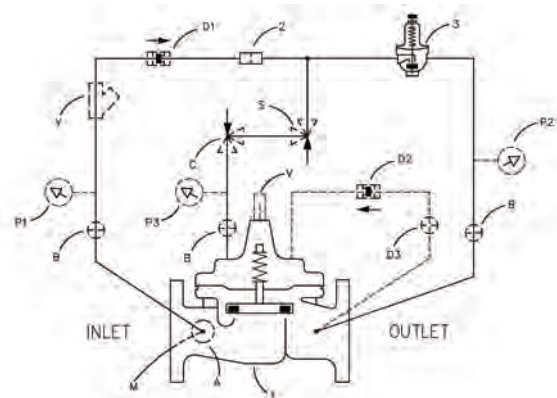

Typical Applications

Typical applications include pressure reducing valve station using Model 690-01 and Model 690-01 in parallel to handle wide range of flow rates. Larger Model 690-01 valve meets requirements of peak loads and smaller Model 690-01S handles low flows.

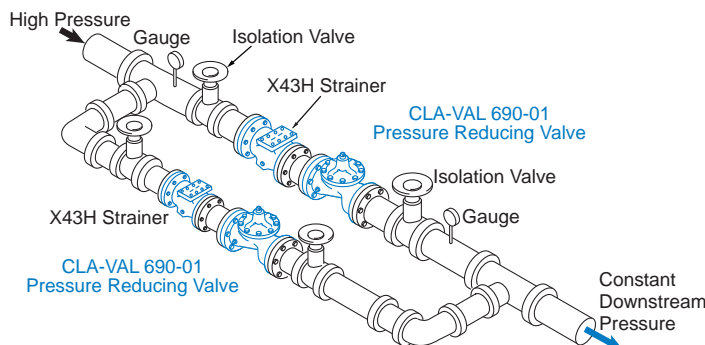

Cla-Val Model 690-01KO Pressure Reducing Valve with Anti-Cavitation Trim provides for optimum downstream pressure control while reducing noise and eliminating damage associated with cavitation. See Cavitation Guide to determine if the valve is a candidate for the KO Anti-Cavitation Trim.

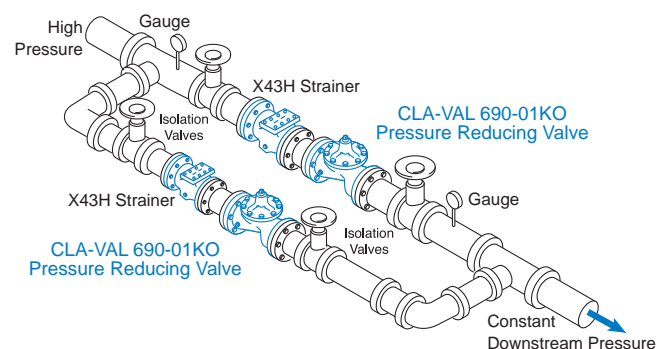

Model 690-01 (Uses 100-20 Hytrol Main Valve)

Pressure Ratings (Recommended Maximum Pressure - psi)

Valve Body & Cover		Pressure Class		
		Flanged		
Grade	Material	ANSI Standards*	150 Class	300 Class
ASTM A536	Ductile Iron	B16.42	250	400
ASTM A216-WCB	Cast Steel	B16.5	285	400
UNS 87850	Bronze	B16.24	225	400

Note: * ANSI standards are for flange dimensions only.
Flanged valves are available faced but not drilled.
Valves for higher pressure are available; consult factory for details

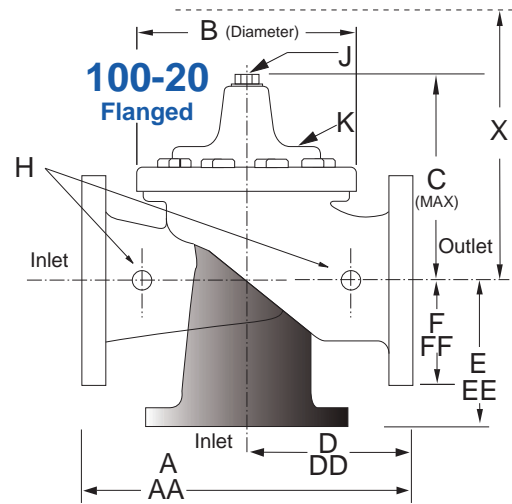

Materials

Component	Standard Material Combinations		
Body & Cover	Ductile Iron	Cast Steel	Bronze
Available Sizes	3" - 48"	3" - 16"	3" - 16"
	80 - 1200mm	80 - 400mm	80 - 400mm
Disc Retainer & Diaphragm Washer	Cast Iron	Cast Steel	Bronze
Trim: Disc Guide, Seat & Cover Bearing	Bronze is Standard Stainless Steel is Optional		
Disc	Buna-N® Rubber		
Diaphragm	Nylon Reinforced Buna-N® Rubber		
Stem, Nut & Spring	Stainless Steel		

For material options not listed, consult factory.
Cla-Val manufactures valves in more than 50 different alloys.

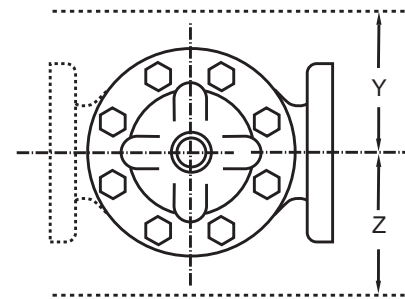

Model 690-01 Dimensions (In Inches)

Valve Size (Inches)	3	4	6	8	10	12	14	16	18	20	24	30	36	48
A 150 ANSI	10.25	13.88	17.75	21.38	26.00	30.00	34.25	35.00	42.12	48.00	48.00	63.25	65.00	88.0
AA 300 ANSI	11.00	14.50	18.62	22.38	27.38	31.50	35.75	36.62	43.63	49.62	49.75	63.75	67.00	90.62
B Diameter	6.62	9.12	11.50	15.75	20.00	23.62	27.47	28.00	35.44	35.44	35.44	53.19	56.00	66.00
C Maximum	7.00	8.62	11.62	15.00	17.88	21.00	20.88	25.75	25.00	31.50	31.50	43.94	54.75	59.00
D 150 ANSI	—	6.94	8.88	10.69	CF*	17.00	CF*	CF*	CF*	CF*	21.06	—	—	—
DD 300 ANSI	—	7.25	9.38	11.19	CF*	17.75	CF*	CF*	CF*	CF*	CF*	—	—	—
E 150 ANSI	—	5.50	6.75	7.25	CF*	13.75	CF*	CF*	CF*	CF*	15.94	—	—	—
EE 300 ANSI	—	5.81	7.25	7.75	CF*	14.75	CF*	CF*	CF*	CF*	CF*	—	—	—
F 150 ANSI	3.75	4.50	5.50	6.75	8.00	9.50	11.00	11.75	15.88	14.56	17.00	19.88	25.50	34.00
FF 300 ANSI	4.12	5.00	6.25	7.50	8.75	10.25	11.50	12.75	15.88	16.06	19.00	22.00	27.50	38.50
H NPT Body Tapping	0.375	0.50	0.75	0.75	1.00	1.00	1.00	1.00	1.00	1.00	1.00	1.00	2.00	2.00
J NPT Cover Center Plug	0.50	0.50	0.75	0.75	1.00	1.00	1.25	2.00	2.00	2.00	2.00	2.00	2.00	2.00
K NPT Cover Tapping	0.375	0.50	0.75	0.75	1.00	1.00	1.00	1.00	1.00	1.00	1.00	1.00	2.00	2.00
Stem Travel	0.60	0.80	1.10	1.70	2.30	2.80	3.40	4.50	4.50	4.50	6.50	7.50	7.50	8.50
Approx. Ship Weight (lbs)	45	85	195	330	625	900	1250	1380	2365	2551	2733	6500	8545	13100
Approx. X Pilot System	13	15	27	30	33	36	36	41	40	46	55	68	79	86
Approx. Y Pilot System	10	11	18	20	22	24	26	26	30	30	30	39	40	47
Approx. Z Pilot System	10	11	18	20	22	24	26	26	30	30	30	39	42	49

*Consult Factory

For sizes 18 through 48-inches, use 690-66 E-Sheet

Model 690-01 Metric Dimensions (Uses 100-20 Hytrol Main Valve)

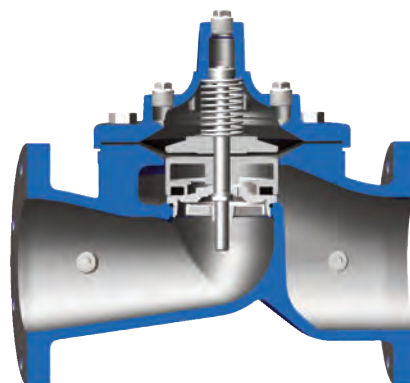
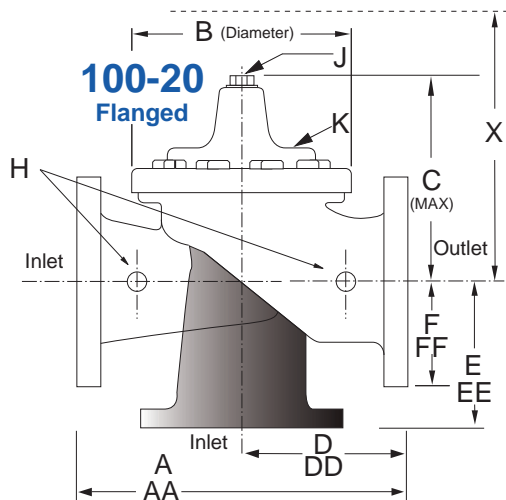

Model 100-20 Reduced Port Hytrol Main Valve

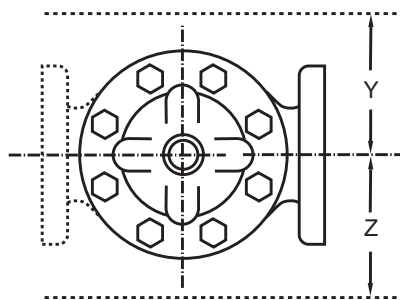

Model 690-01 Dimensions (In mm)

Valve Size (mm)	80	100	150	200	250	300	350	400	450	500	600	750	900	1200
A 150 ANSI	260	353	451	543	660	762	870	889	1070	1219	1219	1607	1651	2235
AA 300 ANSI	279	368	473	568	695	800	908	930	1108	1260	1263	1619	1702	2302
B Diameter	168	232	292	400	508	600	698	711	900	900	900	1351	1422	1676
C Maximum	178	219	295	381	454	533	530	654	635	800	800	1116	1391	1499
D 150 ANSI	—	176	226	272	CF*	432	CF*	CF*	CF*	CF*	CF*	535	—	—
DD 300 ANSI	—	184	238	284	CF*	451	CF*	CF*	CF*	CF*	CF*	—	—	—
E 150 ANSI	—	140	171	184	CF*	349	CF*	CF*	CF*	CF*	CF*	405	—	—
EE 300 ANSI	—	148	184	197	CF*	368	CF*	CF*	CF*	CF*	CF*	—	—	—
F 150 ANSI	95	114	140	171	203	241	279	289	403	370	432	505	648	864
FF 300 ANSI	105	127	159	191	222	260	292	324	403	408	483	559	699	978
H NPT Body Tapping	0.375	0.50	0.75	0.75	1.00	1.00	1.00	1.00	1.00	1.00	1.00	1.00	2.00	2.00
J NPT Cover Center Plug	0.50	0.50	0.75	0.75	1.00	1.00	1.25	2.00	2.00	2.00	2.00	2.00	2.00	2.00
K NPT Cover Tapping	0.375	0.50	0.75	0.75	1.00	1.00	1.00	1.00	1.00	1.00	1.00	1.00	2.00	2.00
Stem Travel	15	20	28	43	58	71	86	86	114	114	114	165	191	216
Approx. Ship Weight (kgs)	20	39	89	150	284	409	568	627	681	1157	1249	2951	3876	5942
Approx. X Pilot System	331	381	686	762	839	915	915	1042	1016	1169	1397	1728	2007	2185
Approx. Y Pilot System	254	280	458	508	559	610	661	661	762	762	762	991	1016	1194
Approx. Z Pilot System	254	280	458	508	559	610	661	661	762	762	762	991	1067	1245

*Consult Factory

For sizes 450 through 1200mm, use 690-66 E-Sheet

690-01 Valve Selection	100-20 Pattern: Globe (G), Angle (A), End Connections: Flanged (F) Indicate Available Sizes															
	Inches	3	4	6	8	10	12	14	16	18	20	24	30	36	42	48
	mm	80	100	150	200	250	300	350	400	450	500	600	750	900	1000	1200
Main Valve 100-20	Pattern	G	G, A	G, A	G, A	G	G	G	G	G	G	G	G	G	G	G
	End Detail	F	F	F	F	F	F	F	F	F	F	F	F	F	F	F
Suggested Flow (gpm)	Maximum	260	580	1025	2300	4100	6400	9230	9230	16500	16500	16500	28000	42000	57000	57000
	Minimum	1	2	4	10	15	35	50	50	95	95	95	275	450	450	450
Suggested Flow (Liters/Sec)	Maximum	16	37	65	145	258	403	581	581	1040	1040	1040	1764	2115	2115	2115
	Minimum	.06	.13	.25	.63	.95	2.2	3.2	3.2	6.0	6.0	6.0	17.4	28.4	41.0	41.0

100-20 Series is the reduced internal port size version of the 100-01 Series.

For Lower Flows Consult Factory

Notes:

- For sizes 18 through 48-inches / 450mm through 1200mm, use 690-66 E-Sheet
- Many factors should be considered in sizing pressure reducing valves including inlet pressure, outlet pressure and flow rates.
- For sizing questions or cavitation analysis, consult Cla-Val with system details.

Pilot System Specifications



Adjustment Ranges
 2 to 30 psi
 15 to 75 psi
 20 to 105 psi
 30 to 300 psi
 150 to 600 psi (CRD-18)
 *Supplied unless otherwise specified
Temperature Range
 Water: to 180°F

Materials

Standard Pilot System Materials

Pilot Control: Low Lead Bronze
 Trim: Stainless Steel Type 303
 Rubber: Buna-N® Synthetic Rubber

Optional Pilot System Materials

Pilot Systems are available with optional Stainless Steel or Monel materials.
 Note: Available with remote sensing control.

When Ordering, Specify:

1. Catalog No. 690-01
2. Valve Size
3. Pattern - Globe or Angle
4. Pressure Class
5. Threaded, Flanged or Grooved
6. Trim Material
7. Adjustment Range
8. Desired Options
9. When Vertically Installed

Main Valve Options

EPDM Rubber Parts

Optional diaphragm, disc and o-ring fabricated with EPDM synthetic rubber

Viton® Rubber Parts - suffix KB

Optional diaphragm, disc and o-ring fabricated with Viton® synthetic rubber

Epoxy Coating - suffix KC

NSF/ANSI 61 Fusion Bonded Epoxy

Dura-Kleen® Stem - suffix KD

Fluted design prevents dissolved minerals build-up on the stem

LFS Trim

Designed to regulate precisely and smoothly at typical flow rates as well as lower than the industry standard of 1 fps, without decreasing the valve's capacity

Valve Options

X141 Pressure Gauge



X101AR Valve Position Indicator with Air Release



X101 Valve Position Indicator



X144 e-FlowMeter



X43H Strainer



Stainless Steel Pilot